

Martin® Skirtboard Liner with T-Bolt Slot



Installed inside conveyor transfer point skirtboards, [Martin® Skirtboard Liner with T-Bolt Slot](#) absorb impact and abrasion and creates a dam to shield the sealing system from the weight of the material load, prolonging the life of the seal.

The Martin® Skirtboard Liner with T-Bolt Slot feature a steel plate molded inside the urethane to prevent bond issues. Liners are also stackable to line higher drop chutes.

SKIRTBOARD LINER WITH T-BOLT SLOT Nomenclature

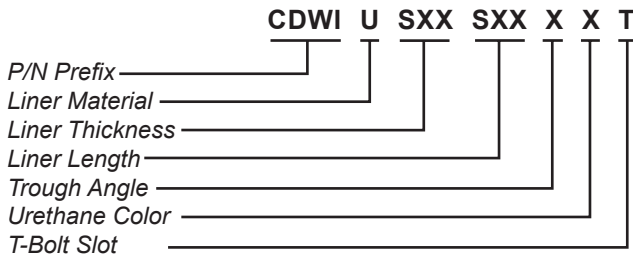

LINER MATERIAL

U: Urethane

LINER THICKNESS

13: 1.25 inches
20: 2.00 inches

LINER LENGTH

24: 24 inches
36: 36 inches
48: 48 inches

TROUGH ANGLE

2: 20 degree
3: 35 degree
4: 45 degree
F: 0 degree Flat

URETHANE COLOR

- O: Orange (General Conditions)
- B: Brown (Corrosive or High Moisture)
- G: Green (High Temperature)

T-BOLT SLOT

- T: With T-Bolt Slot

SKIRTBOARD LINER WITH T-BOLT SLOT & HARDWARE KIT Nomenclature

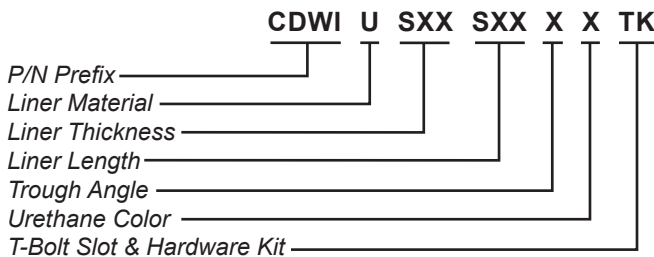

LINER MATERIAL

U: Urethane

LINER THICKNESS

13: 1.25 inches
20: 2.00 inches

LINER LENGTH

24: 24 inches
36: 36 inches
48: 48 inches

TROUGH ANGLE

2: 20 degree
3: 35 degree
4: 45 degree
F: 0 degree Flat

URETHANE COLOR

- O: Orange (General Conditions)
- B: Brown (Corrosive or High Moisture)
- G: Green (High Temperature)

T-BOLT SLOT & HARDWARE KIT

- TK: T-Bolt Slot & Hardware Kit

URETHANE COLOR PARTS LIST

Part Number	Color
CDWIUSXXSXXXOT	Orange
CDWIUSXXSXXXBT	Brown
CDWIUSXXSXXXGT	Green

TECHNICAL DATA SHEET

DIMENSIONS — MM (IN.)

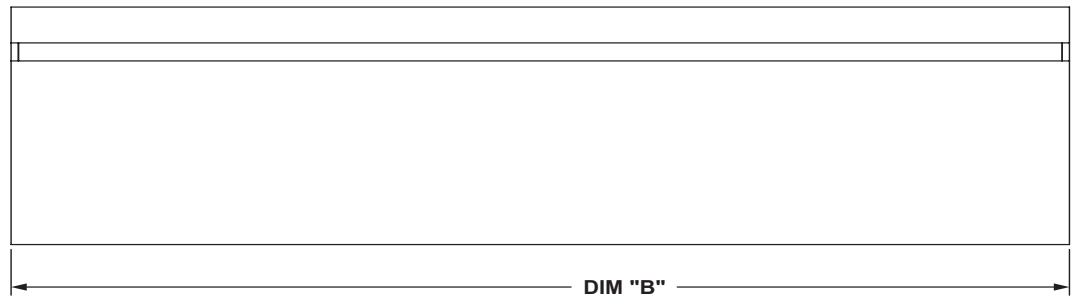
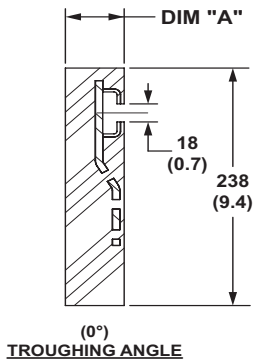
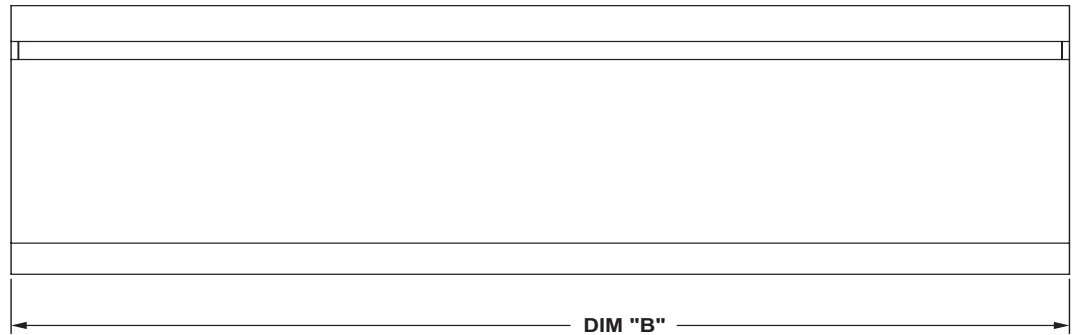
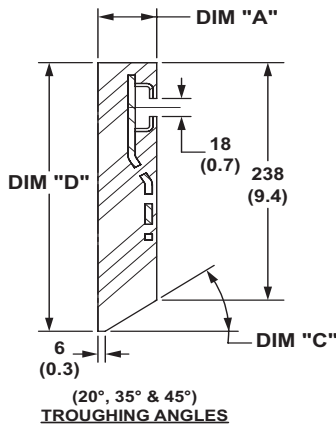

Part Number*	Dim "A" - mm (in.)	Dim "B" - mm (in.)	Dim "C"	Dim "D" - mm (in.)
CDWIUS13S482XT	31.8 (1.25)	1219.2 (48.00)	20°	246.7 (9.71)
CDWIUS13S483XT	31.8 (1.25)	1219.2 (48.00)	35°	255.3 (10.05)
CDWIUS13S484XT	31.8 (1.25)	1219.2 (48.00)	45°	262.9 (10.35)
CDWIUS13S48FXT	31.8 (1.25)	1219.2 (48.00)	0°	N/A
CDWIUS20S242XT	50.8 (2.00)	609.6 (24.00)	20°	253.7 (9.99)
CDWIUS20S243XT	50.8 (2.00)	609.6 (24.00)	35°	268.6 (10.58)
CDWIUS20S244XT	50.8 (2.00)	609.6 (24.00)	45°	281.9 (11.10)
CDWIUS20S24FXT	50.8 (2.00)	609.6 (24.00)	0°	N/A
CDWIUS20S362XT	50.8 (2.00)	914.4 (36.00)	20°	253.7 (9.99)
CDWIUS20S363XT	50.8 (2.00)	914.4 (36.00)	35°	268.6 (10.58)
CDWIUS20S364XT	50.8 (2.00)	914.4 (36.00)	45°	281.9 (11.10)
CDWIUS20S36FXT	50.8 (2.00)	914.4 (36.00)	0°	N/A

* The "X" in the part number indicates skirboard liner color: O = Orange (General Conditions), B = Brown (Corrosive or High Moisture), G = Green (High Temperature).



Martin Engineering AUS
102 Christensen Road South
Stapylton, QLD 4207 AUS
+61 1300 627 364
www.martin-eng.com.au

