

Martin® SQC2S™ Reduced Mini Cleaner

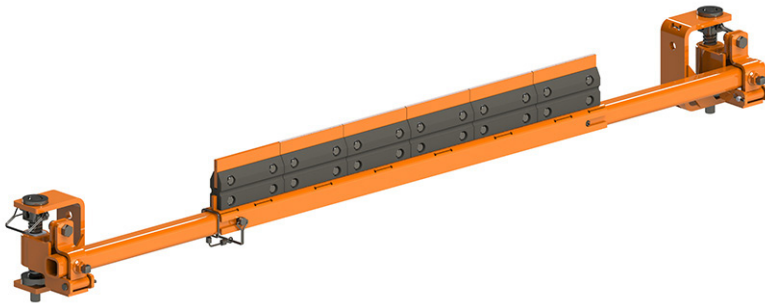

The [Martin® SQC2S™ Reduced Mini Cleaner](#) incorporates individually-cushioned tungsten carbide blades for effective cleaning without risk to belt, splice, or blade. Installed in the secondary cleaner position, the Martin® SQC2S™ Cleaner’s blade buffers cushion impact and maintains cleaning pressure.

BENEFITS

- Cushioned Blades Maintain Efficiency**
 Patented rubber buffers maintain cleaning pressure while deflecting to allow splices to pass.
- Built for Tough Conditions**
 Rugged construction withstands punishing applications, like high-speed belts and high-tonnage loads.
- Easy Cartridge Removal**
 The procedure is simple: remove pin, slide out cartridge, service, and return.
- Easy Adjustment of Cleaning Pressure**
 Martin® SQC2S™ Tensioners allows simple alteration of blade-to-belt pressure to maintain cleaning efficiency regardless of blade wear. Lock pin keeps tensioner in place to maintain constant tension.
- Fits in Tight Spaces**
 Compact design allows installation in close quarters; narrow profile resists material buildup.
- Blades to Match Application**
 Specify tungsten carbide tips for normal, acidic, or high-impact conditions. Blades conform to belt profile by adjusting individually to provide continuous contact across the belt.
- Handles Reversing Belts and Belt Rollback**
 Rubber buffers allow for reversal of belt direction without damage to belt.

ACCESSORIES

PART	P/N
Martin® SQC2S™ Split-Cover Door	38014-SQC2RM
Martin® Hanger Mount Heavy-Duty Assembly	34233-HD
Martin® SQC2S™ Square Mainframe Tensioner	39448

TECHNICAL DATA SHEET

NOMENCLATURE SQC2RM-XX X XX XX X X X

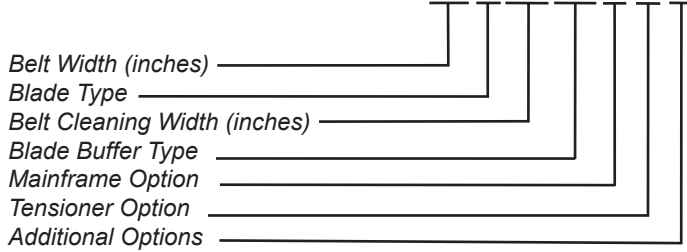

BLADE TYPE

- C:** Corrosion Resistant with Tungsten Carbide Tips
- R:** General Applications and Reversing Belts—Tungsten Carbide
- Ø:** No Blades

BLADE CLEANING WIDTH

Full belt width or Approx.
6 inches less belt width.

BLADE BUFFER TYPE

- MR:** Molded Rubber
- ØØ:** No Buffers

MAINFRAME OPTIONS

- P:** Painted
- S:** Stainless Steel

TENSIONER OPTIONS

- T:** Tensioner
- S:** Stainless Steel Tensioner
- Ø:** No Tensioner

ADDITIONAL OPTIONS

- Ø:** None
- D:** Dust-Tight Steel Cover Door
- S:** Stainless Steel Cover Door

MARTIN® SQC2S™ BLADES*

COLOR	GENERAL APPLICATION	Replacement Blade P/N
—	Corrosion Resistant Stainless Steel with TC Tips	SCM-MRC
Orange	General Applications and Reversing Belts: TC Blade	SCM-MRR

* Maximum belt speed for Martin® SQC2S™ blades is 1000 FPM.
For other applications, please contact your Martin Engineering representative.
TC = Tungsten

TECHNICAL DATA SHEET

DIMENSIONS

Belt Width		DIM "A" in. (mm)		# of Blades (Belt Width minus 6")	# of Blades (Full Belt Width)
18	(450)	48.00	(1219)	2	3
24	(600)	54.00	(1372)	3	4
30	(750)	60.00	(1524)	4	5
36	(900)	66.00	(1676)	5	6
42	(1050)	72.00	(1829)	6	7
48	(1200)	78.00	(1981)	7	8
54	(1350)	84.00	(2134)	8	9
60	(1500)	90.00	(2286)	9	10
66	(1650)	96.00	(2438)	10	11
72	(1800)	102.00	(2591)	11	12

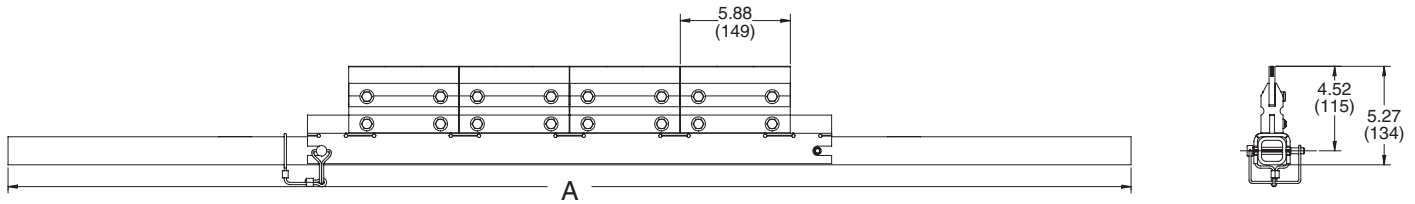

APPLICATION NOTES

Martin Engineering recommends that the Martin® SQC2S™ Cleaner be installed so the cleaning blade contacts the belt at a point 2 to 4 in. (51 to 102 mm) after the point where the belt leaves the head (discharge) pulley. If obstructions prevent installation at this point, or if additional cleaners are desired, the cleaner should be installed 2 to 4 in. (51 to 102 mm) past the point where the belt leaves the support idler.

See your Martin Engineering representative for more information, or visit www.martin-eng.com.

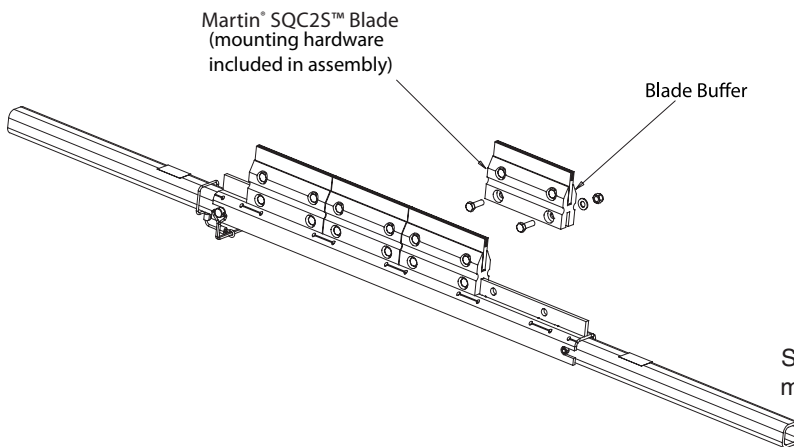
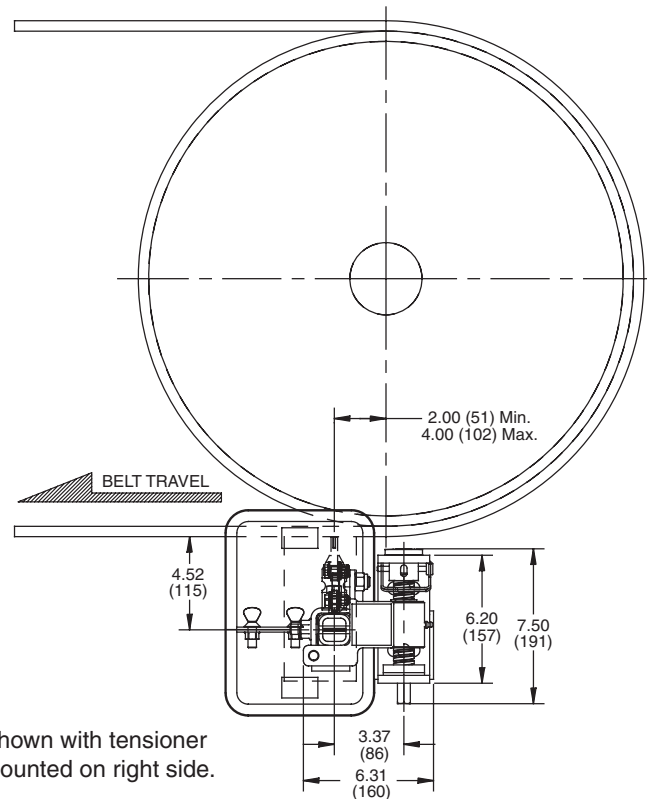

Martin Engineering USA
 102 Christensen Road South
 Stapylton QLD 4207 - Australia
 +61 1300 627 364
salesau@martin-eng.com | www.martin-eng.com.au

**COMPANY WITH
 QUALITY SYSTEM
 CERTIFIED BY DNV
 = ISO 9001:2008 =**