

Martin® QC1™ Cleaner XHD



The [Martin® QC1™ Cleaner XHD](#) tackles the tough jobs. Designed for rugged conditions, this sturdy cleaner features a one-pin blade change, making replacement of a worn blade a simple procedure.

The Martin® QC1™ Cleaner XHD includes a Spring Tensioner to maintain proper cleaning pressure while minimizing the need for adjustment.

Dual tensioners are supplied with cleaners for belts 48 in. (1219 mm) wide or wider.

NOMENCLATURE

35899- XX 1 X XX XX X

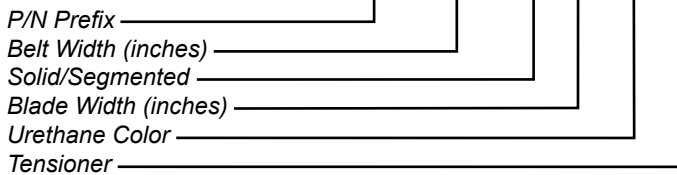

35899D XX 1 X XX XX X

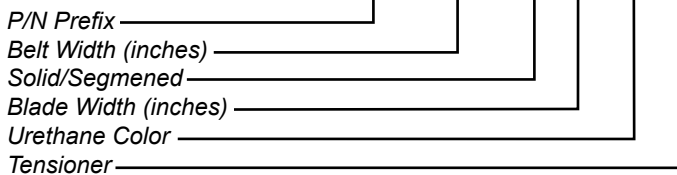

URETHANE COLOR

- BR:** Brown
- CL:** Tan
- GR:** Green
- NB:** Navy Blue
- YL:** Yellow
- CY:** Yellow with Ceramic Beads
- Blank:** Orange

SOLID/SEGMENTED

- 0:** Segmented Blade
- 1:** Solid Blade

TENSIONER

- T:** Martin® Spring Tensioner XHD
- Blank:** No Tensioner

BENEFITS

- **Fast Blade Change Cuts Service Expense**
One-pin blade replacement makes blade replacement a fast and easy operation.
- **Matched Tensioner Maintains Consistent Cleaning**
Martin® QC1™ Cleaner XHD and Spring Tensioner are system-engineered to preserve the cleaning edge from high belt speeds and multiple splices.
- **Curved Blade Provides Consistent Cleaning**
Patented “CARP” (Constant Angle Radial Pressure) design maintains cleaning performance through all stages of blade life.
- **Rugged Construction Suits Tough Conditions**
Mainframe of rugged 3/8-in. (9.5-mm) thick DOM steel tubing has steel bar backbone. Aluminum extrusion in blade base holds cleaner snugly to backbone.
- **Blade Materials Match Application**
Martin Engineering’s urethane expertise provides blades to suit standard, high-temperature, or high-abrasion conditions.
- **The Most Cleaner, the Least Investment**
Economical pre-cleaner and tensioner system combines effective cleaning, durable life, and low-maintenance requirements.

NOTES

Martin® QC1™ Cleaners XHD are available for belts up to 120 in. (3048 mm) wide. For belts wider than 72 in. (2000 mm) a dual-blade assembly is required.

Normal blade length is belt width less 6 in. (150 mm). For belts with a 45° trough or where material is centered on belt, customer should consider a blade that is belt width less 12 in. (300 mm). This is because belt edges may not require cleaning, and blade-to-belt friction in these areas may lead to premature wear of cleaner and/or belt.

Martin® QC1™ Cleaner XHD will mount into existing Martin® DT1 Cleaner XHD locations. Martin® QC1™ Blades XHD will NOT fit onto Martin® DT1 Mainframe XHD.

Example #1: P/N 35899-481042T is a belt cleaner for a 48-in. wide belt, with segments, standard orange urethane blade. Blade coverage is belt width minus 6 in., with a Spring Tensioner XHD.

Example #2: P/N 35899-601148BR is a belt cleaner for a 60-in. wide belt, with solid brown urethane blade that is 48 in. Blade coverage is belt width minus 12 in., with no tensioner included.

TECHNICAL DATA SHEET

SPECIFICATIONS & DIMENSIONS – in. (mm)

Part Number 35899-XXXXXXX (belt width less 6 in.)						
Assembly Part Number	Belt Width in (mm)	Dim. A Blade in (mm)	Replacement Blade Part Number	Dim. B Frame in (mm)	Cleaner Ship Wt. lb (kg)	Tensioner Ship Wt. lb (kg)
35899-18XX12XXX	18 (457)	12 (305)	35897-18XXXX	66 (1676)	75 (34)	40 (18)
35899-24XX18XXX	24 (610)	18 (457)	35897-24XXXX	72 (1829)	90 (41)	40 (18)
35899-30XX24XXX	30 (762)	24 (610)	35897-30XXXX	78 (1981)	105 (48)	40 (18)
35899-36XX30XXX	36 (915)	30 (762)	35897-36XXXX	84 (2134)	120 (54)	40 (18)
35899-42XX36XXX	42 (1067)	36 (915)	35897-42XXXX	90 (2286)	135 (61)	40 (18)
35899-48XX42XXX*	48 (1219)	42 (1067)	35897-48XXXX	96 (2438)	150 (68)	51 (23)*
35899-54XX48XXX*	54 (1372)	48 (1219)	35897-54XXXX	102 (2590)	165 (74)	51 (23)*
35899-60XX54XXX*	60 (1524)	54 (1372)	35897-60XXXX	108 (2743)	180 (81)	51 (23)*
35899-66XX60XXX*	66 (1676)	60 (1524)	35897-66XXXX	114 (2896)	195 (88)	51 (23)*
35899-72XX66XXX*	72 (1829)	66 (1676)	35897-72XXXX	120 (3048)	210 (95)	51 (23)*
Part Number 35899-XXXXXXXX (belt width less 12 in.)						
35899-24XX12XXX	24 (610)	12 (305)	35897-18XXXX	72 (1829)	86 (39)	40 (18)
35899-30XX18XXX	30 (762)	18 (457)	35897-24XXXX	78 (1981)	100 (45)	40 (18)
35899-36XX24XXX	36 (915)	24 (610)	35897-30XXXX	84 (2134)	114 (51)	40 (18)
35899-42XX30XXX	42 (1067)	30 (762)	35897-36XXXX	90 (2286)	128 (58)	40 (18)
35899-48XX36XXX	48 (1219)	36 (915)	35897-42XXXX	96 (2438)	143 (64)	40 (18)
35899-54XX42XXX*	54 (1372)	42 (1067)	35897-48XXXX	102 (2590)	158 (71)	51 (23)*
35899-60XX48XXX*	60 (1524)	48 (1219)	35897-54XXXX	108 (2743)	173 (78)	51 (23)*
35899-66XX54XXX*	66 (1676)	54 (1372)	35897-60XXXX	114 (2896)	188 (85)	51 (23)*
35899-72XX60XXX*	72 (1829)	60 (1524)	35897-66XXXX	120 (3048)	203 (92)	51 (23)*

* Requires dual tensioners P/N 38003-2

Martin® QC1™ Cleaner XHD
P/N 35899-XXXXXXXXXX

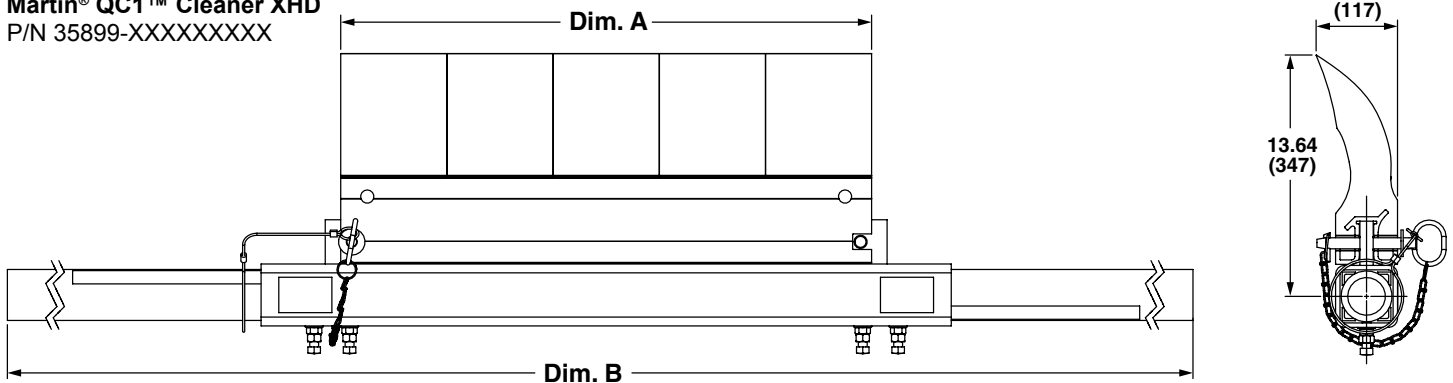

Spring Tensioner XHD
P/N 38003

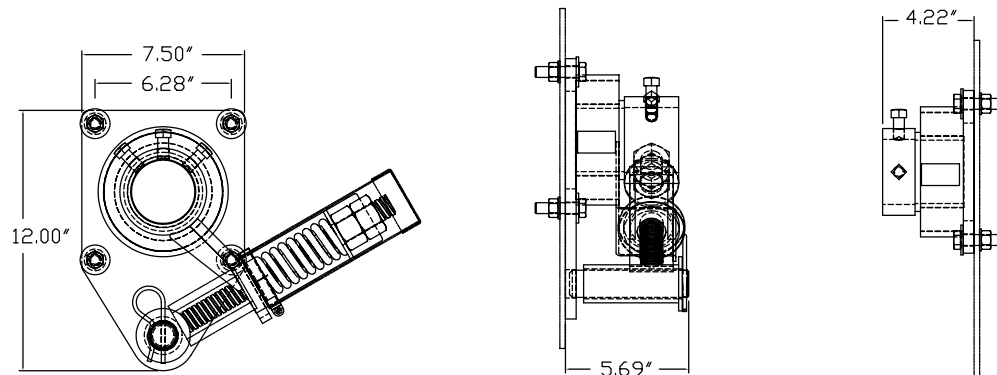

Problem Solved™ GUARANTEED!

Form No. L3501-4/21
© Martin Engineering Company 2008, 2021

TECHNICAL DATA SHEET

SPECIFICATIONS & DIMENSIONS – in. (mm)

Part Number 35899DXXXXXXXXXX (belt width less 6 in.)						
Assembly Part Number*	Belt Width in (mm)	Dim. A Blade Coverage in (mm)	Dim. A / 2 Blade Width in (mm)	Replacement Blade Part Number**	Dim. B Frame in (mm)	Cleaner Ship Wt. lb (kg)
35899D54XX48XXX	54 (1372)	48 (1219)	24 (610)	35897-30XXXX	102 (2591)	222 (101)
35899D60XX54XXX	60 (1524)	54 (1372)	27 (686)	35897-33XXXX	108 (2743)	239 (108)
35899D72XX66XXX	72 (1829)	66 (1676)	33 (838)	35897-36XXXX	120 (3048)	272 (123)
35899D78XX72XXX	78 (1981)	72 (1829)	36 (914)	35897-39XXXX	126 (3200)	289 (131)
35899D84XX78XXX	84 (2134)	78 (1981)	39 (991)	35897-45XXXX	132 (3353)	306 (139)
35899D96XX90XXX	96 (2438)	90 (2286)	45 (1143)	35897-48XXXX	144 (3658)	339 (154)
35899D102XX96XXX	102 (2591)	96 (2438)	48 (1219)	35897-51XXXX	150 (3810)	356 (162)
35899D108XX102XXX	108 (2743)	102 (2591)	51 (1295)	35897-54XXXX	156 (3962)	373 (169)
35899D114XX108XXX	114 (2896)	108 (2743)	54 (1372)	35897-57XXXX	168 (4267)	398 (181)
35899D120XX114XXX	120 (3048)	114 (2896)	57 (1448)	35897-60XXXX	168 (4267)	407 (185)
35899D126XX120XXX	126 (3200)	120 (3048)	60 (1524)	35897-63XXXX	174 (4420)	424 (192)
Part Number 35899DXXXXXXXXXX (belt width less 12 in.)						
35899D84XX72XXX	84 (2134)	72 (1829)	36 (914)	35897-42XXXX	132 (3353)	297 (135)
35899D96XX84XXX	96 (2438)	84 (2134)	42 (1067)	35897-48XXXX	144 (3658)	331 (150)

* All assemblies require dual tensioners P/N 38003-2.

**Quantity 2 required.

Martin® QC1™ Cleaner XHD
P/N 35899DXXXXXXXXXX

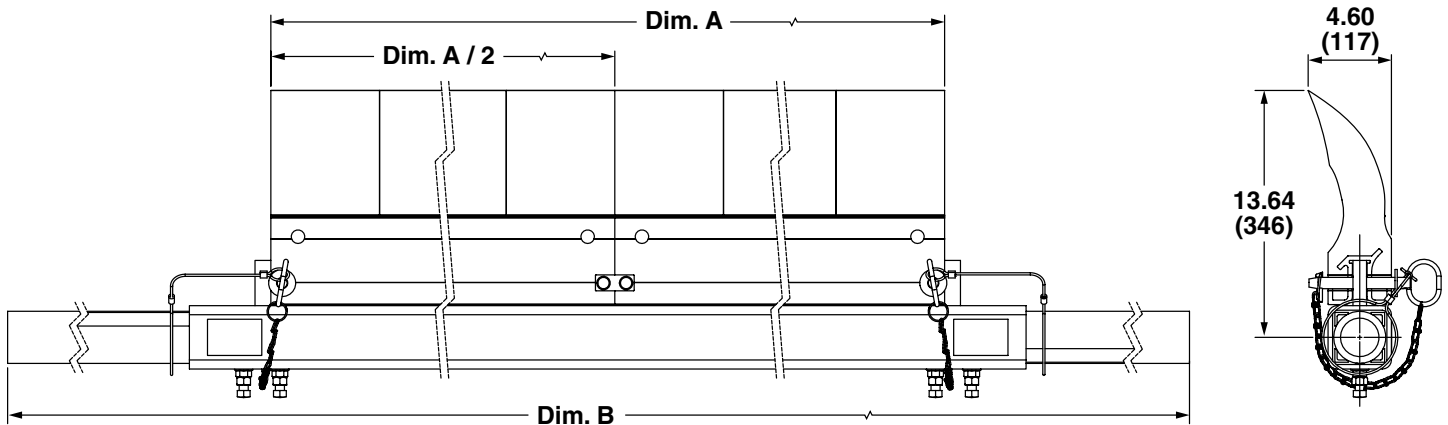

TECHNICAL DATA SHEET

INSTALLATION AND MOUNTING

Installation Recommendations:

Head Pulley Diameter	24 in. – 30 in. (609.6 – 762 mm)
Maximum Belt Speed	1200 fpm (6 m/s)

Mounting Location:

Head Pulley Diameter*	Mounting Dimension
16 in. (400 mm)	5.75 (146)
20 in. (500 mm)	5.50 (140)
24 in. (600 mm)	5.25 (133)
28 in. (700 mm)	5.00 (127)
30 in. (750 mm)	4.75 (120)

* includes belt and lagging

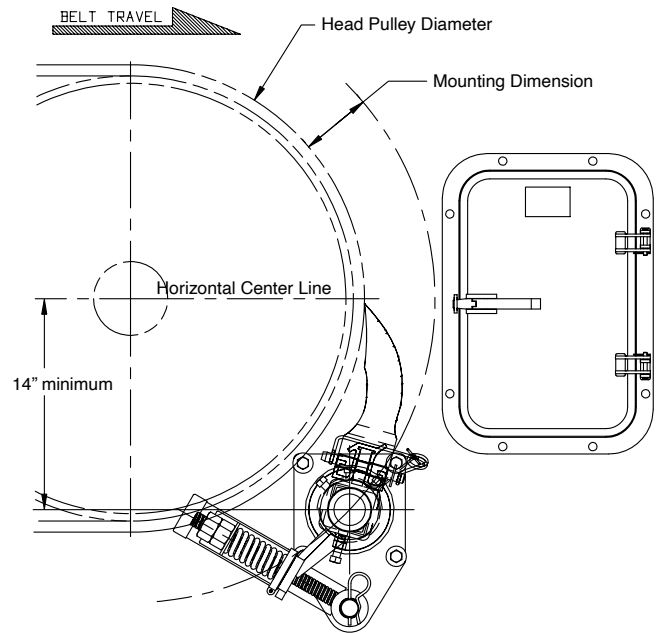

TENSIONER OPTIONS

Tensioner	P/N	Blade Width
Martin® Spring Tensioner XHD	38003	36 in. (915 mm) or less
Martin® Spring Tensioner XHD Dual	38003-2	42 in. (1067 mm) or greater
Martin® Air Tensioner XHD	32135	42 in. (1067 mm) or less
Martin® Air Tensioner XHD Dual	32135-2R	48 in. (1372 mm) or greater

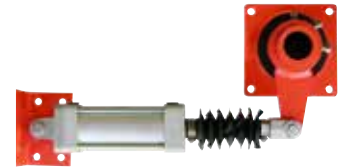

REPLACEMENT BLADE NOMENCLATURE

35897-XX 1 X XX

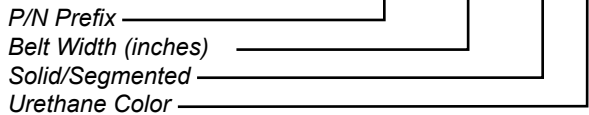

SOLID/SEGMENTED

0: Segmented Blade
1: Solid Blade

URETHANE COLOR

BR: Brown
CL: Tan
GR: Green
NB: Navy Blue
YL: Yellow
CY: Yellow with Ceramic Beads
Blank: Orange

Note: For dual blade cleaners divide total blade width by 2. 78" (1981 mm) and larger cleaners always have dual blades.

Example #1: P/N 35897-5110GR is a replacement blade for a dual blade assembly that has a 90-in. blade width, with segments, and green urethane.

FREQUENTLY ASKED QUESTIONS

My Pre-Cleaner keeps flipping through. What is wrong?
The mounting location may be too far away from the belt. Relocate to the proper mounting location. Replace the mainframe or end weldments if they are bent. Check set screws to determine if they are tight. Retighten if necessary.

My Pre-Cleaner is wearing more in the center of the blade.
The blade is too wide for this application. Replace with a shorter length blade.

ACCESSORIES

PART	P/N
Martin® Steel Inspection Door	CYA-1218
Martin® Hanger Mount XHD Assembly	27382-SL



Martin Engineering Australia Pty Ltd.
102 Christensen Road South
Stapylton QLD 4207 - Australia
+61 1300 627 364
salesau@martin-eng.com | www.martin-eng.com.au



Problem Solved™ GUARANTEED!

Form No. L3501-4/21
© Martin Engineering Company 2008, 2021