

Martin® QC1™ Cleaner PD



The **Martin® QC1™ Cleaner PD** provides maximum durability and performance across a wide range of duties and applications. This sturdy cleaner features one-pin blade change, making replacement of a worn blade a simple procedure. The one-piece urethane blade has a “CARP” (Constant Angle Radial Pressure) design to maintain cleaning performance through all stages of blade life.

The Martin® QC1™ PD Cleaner includes a Spring Tensioner to maintain proper cleaning pressure while minimizing the need for adjustment.

SPECIFICATIONS

Maximum Belt Speed fpm (m/sec)	Maximum Service Temperature	Pulley Diameter in. (mm)	Mounting Location**		Wear Life* in. (mm)	Wear Volume (per inch of blade) in ³ (cm ³)
			Pulley Diameter	Mounting Dimension		
900 (4.6)	160°F (70°C) Continuous 180°F (82°C) Intermittent	12-23 (305-584)	12-15 (305-381)	4.0 (100)	4.5 (114)	6.53 (107)
			16-23 (406-584)	3.5 (89)		

* Amount of usable blade

** Pulley diameter 23 in. (584 mm) and greater: contact your Martin Engineering representative.

High-performance urethanes are available; see your Martin Engineering representative for assistance in specifying non-standard products. Refer to Form No. L3375.

NOMENCLATURE

38556 - XX XX XX X

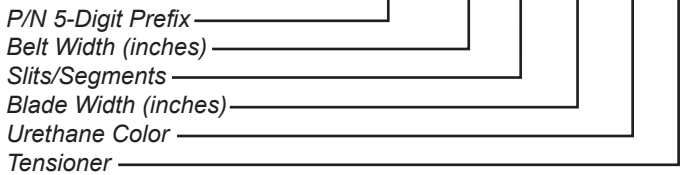

SLITS/SEGMENTS

- 11: No slits or segments
- 10: Segments only
- 01: Slits only
- 00: Slits & Segments

URETHANE COLOR

- BR: Brown
- NB: Navy Blue
- GR: Green
- CL: Tan
- Blank: Orange

TENSIONER

- S: Martin® Spring Tensioner
- T: Martin® Twist Tensioner

Use segmented blade on crowned head pulley.

MOUNTING LOCATION

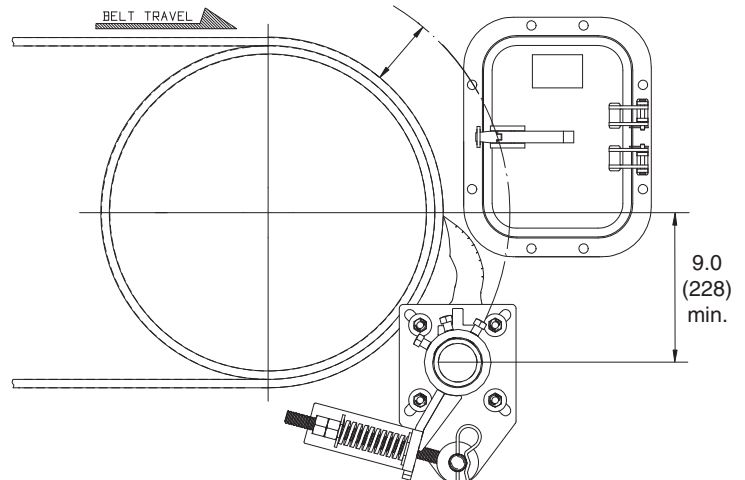

TECHNICAL DATA SHEET

DIMENSIONS -- in. (mm)

* Tensioner not included

Belt Width in. (mm)	Mainframe Length in. (mm)	Belt Coverage Belt Width Less 8" in. (mm)	Belt Coverage Belt Width Less 6" in. (mm)	Belt Coverage Belt Width Less 2" in. (mm)	Shipping Weight* lb. (kg)
18 (400-500)	48 (1219)	10 (254)	12 (305)	16 (406)	43 (20)
24 (500-650)	54 (1372)	16 (406)	18 (457)	22 (559)	51 (23)
30 (650-800)	60 (1524)	22 (559)	24 (610)	28 (711)	59 (27)
36 (800-1000)	66 (1676)	28 (711)	30 (762)	34 (864)	68 (31)
42 (1000-1200)	72 (1829)	34 (864)	36 (914)	40 (1016)	76 (34)
48 (1200-1400)	78 (1981)	40 (1016)	42 (1067)	46 (1168)	84 (38)
54 (1400-1600)	84 (2134)	46 (1168)	48 (1219)	52 (1321)	92 (42)
60 (1600-1800)	90 (2286)	52 (1321)	54 (1372)	58 (1473)	101 (46)
66 (1600-1800)	96 (2438)	58 (1473)	60 (1524)	64 (1626)	109 (49)
72 (1800-2000)	102 (2591)	64 (1626)	66 (1676)	70 (1778)	117 (53)
78 (1800-2000)	108 (2743)	70 (1778)	72 (1829)	76 (1930)	126 (57)
84 (2000-2200)	114 (2896)	76 (1930)	78 (1981)	82 (2083)	134 (61)

Notes: Dual Martin® Twist Tensioners are required for belt widths 54 in. (1400 mm) and greater.

Shipping weights shown are for cleaners with belt coverage that is 2 in. less than belt width. Shipping weights for cleaners with 6 in. or 8 in. less belt coverage will be approximately 1.5 to 3 lbs less than shown.

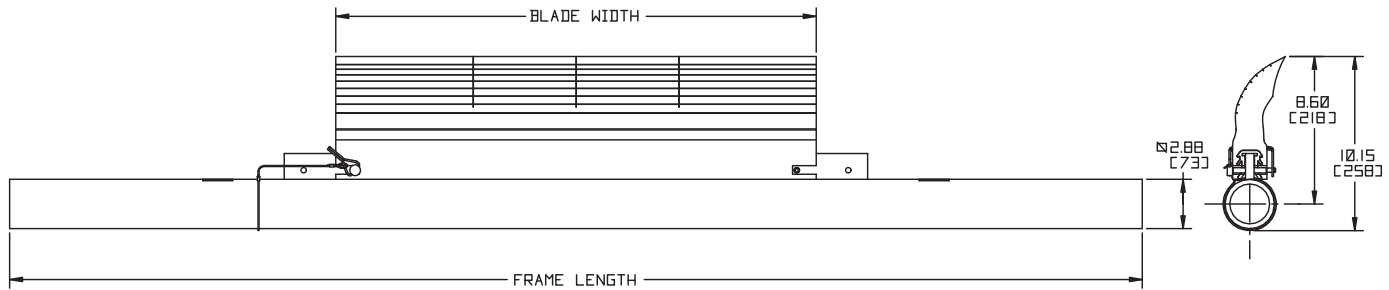

FREQUENTLY ASKED QUESTIONS

My Pre-Cleaner keeps flipping through.

The mounting location may be too far away from the belt. Relocate to the proper dimension. Replace the mainframe if it is bent.

My Pre-Cleaner is wearing more in the center of the blade.

The blade is too wide for this application. Replace with a shorter length blade.

ACCESSORIES

Part	P/N
Martin® Steel Inspection Door	CYA-1218
Martin® Hanger Mount Standard Assembly	27382



Martin Engineering Australia Pty Ltd.
 20 Ern Harley Dr - Burleigh Heads, QLD, 4220 - Australia 1300
 627 364
www.martin-eng.com.au



Problem Solved™ GUARANTEED!

Form No. L3799-08/12
 © Martin Engineering Company 2009, 2012