

Martin® QC1™ Cleaner HD STS

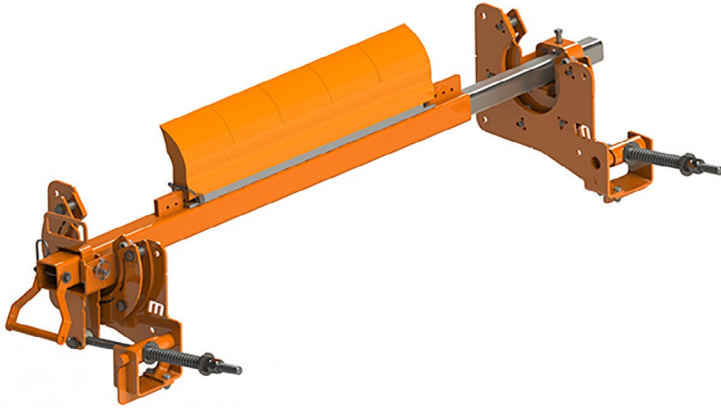

The **Martin® QC1™ Cleaner HD STS** tackles the tough jobs. Designed for rugged conditions, this sturdy cleaner's stainless steel mandrel allows the blade cartridge to be serviced without confined space entry or breaking the safety plane. Changing the blade is a simple one-pin operation, making replacement of a worn blade a safe and simple procedure.

The Martin® QC1™ Cleaner HD STS is available with either a Martin® Spring Tensioner HD STS or a Martin® Air Tensioner HD STS to maintain proper cleaning pressure while minimizing the need for adjustment.

BENEFITS

- Safe To Service**
 The blade can be replaced from outside the chute wall or the conveyor structure without breaking the safety plane.
- Fast Blade Change Cuts Service Expense**
 One-pin blade replacement makes blade replacement a fast and easy operation.
- Matched Tensioner Maintains Consistent Cleaning**
 Martin® QC1™ Cleaner HD STS and Martin® Tensioner HD STS are system-engineered to preserve the cleaning edge from high belt speeds and multiple splices.
- Curved Blade Provides Consistent Cleaning**
 Patented "CARP" (Constant Angle Radial Pressure) design maintains cleaning performance through all stages of blade life.
- Rugged Construction Suits Tough Conditions**
 Mainframe of rugged 3/8-in. (9.5-mm) thick DOM steel tubing has steel bar backbone. Aluminum extrusion in blade base holds cleaner snugly to backbone.
- Blade Materials Match Application**
 Martin Engineering's urethane expertise provides blades to suit standard, high-temperature, or high-abrasion conditions.
- The Most Cleaner, the Least Investment**
 Economical pre-cleaner and tensioner system combines effective cleaning, durable life, and low-maintenance requirements.

NOMENCLATURE

STSHDQC- XX XX XX XX X

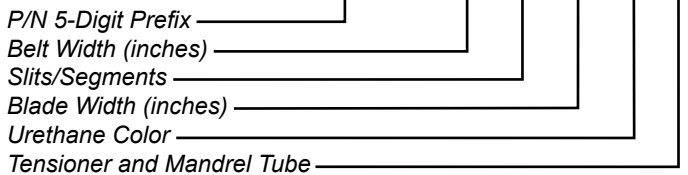

SLITS/SEGMENTS

- 11:** no slits or segments
- 10:** segments only
- 01:** slits only
- 00:** slits & segments

TENSIONER

- A:** Martin® Air Tensioner HD STS
- T:** Martin® Spring Tensioner HD STS
- Blank:** No Tensioner or Mandrel Tube

URETHANE COLOR

- B1:** Black
- BR:** Brown
- CL:** Tan
- GR:** Green
- NB:** Navy Blue
- CY:** Yellow with Beads
- Blank:** Orange

NOTES

Normal blade length is belt width less 6 in. (150 mm). For belts with a 45° trough or where material is centered on belt, customer should consider a blade that is belt width less 8 in. (200 mm). This is because belt edges may not require cleaning, and blade-to-belt friction in these areas may lead to premature wear of cleaner and/or belt.

TECHNICAL DATA SHEET

SPECIFICATIONS & DIMENSIONS – in. (mm)

Part Number	Belt Width in (mm)	Dim. A Blade in (mm)			Dim. B Mainframe in (mm)	Dim. C Mandrel in (mm)
		Belt Width less 2 in.	Belt Width less 6 in.	Belt Width less 8 in.		
STSHDQC-24XX18	24 (610)	22 (559)	18 (457)	16 (406)	38.50 (978)	55.00 (1397)
STSHDQC-30XX24	30 (762)	28 (711)	24 (610)	22 (559)	44.50 (1130)	61.00 (1549)
STSHDQC-36XX30	36 (915)	34 (864)	30 (762)	28 (711)	50.50 (1283)	67.00 (1702)
STSHDQC-42XX36	42 (1067)	40 (1016)	36 (914)	34 (864)	56.50 (1435)	73.00 (1854)
STSHDQC-48XX42	48 (1219)	46 (1168)	42 (1067)	40 (1016)	62.50 (1588)	79.00 (2007)
STSHDQC-54XX48	54 (1372)	52 (1321)	48 (1219)	46 (1168)	68.50 (1740)	85.00 (2159)
STSHDQC-60XX54	60 (1524)	58 (1473)	54 (1372)	52 (1321)	74.50 (1892)	91.00 (2311)
STSHDQC-66XX60	66 (1676)	64 (1626)	60 (1524)	58 (1473)	80.50 (2045)	97.00 (2464)
STSHDQC-72XX66	72 (1829)	70 (1778)	66 (1676)	64 (1626)	86.50 (2197)	103.00 (2616)

MARTIN® QC1™ CLEANER HD STS, P/N STSHDQC-XXXXXXXX

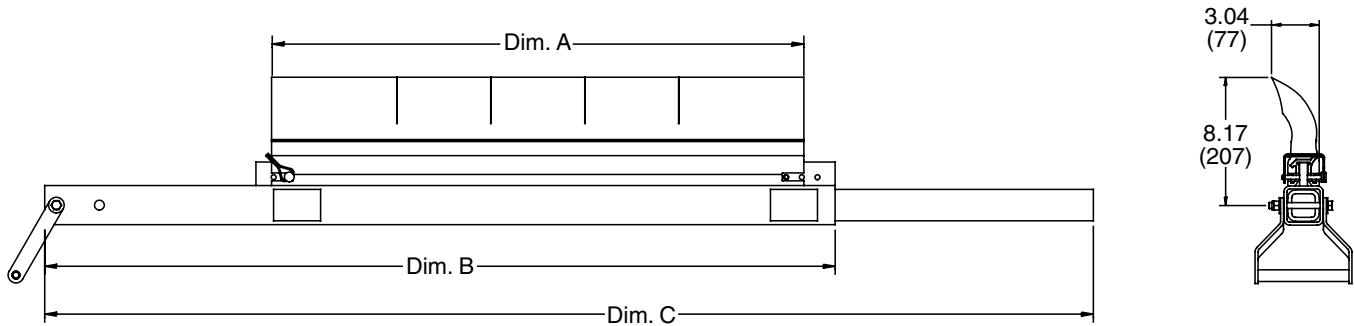

INSTALLATION AND MOUNTING

Installation Recommendations:

Head Pulley Diameter (includes belt and lagging)	16 in. – 22 in. (406 – 559 mm)
Maximum Belt Speed	900 fpm (4.6 m/s)

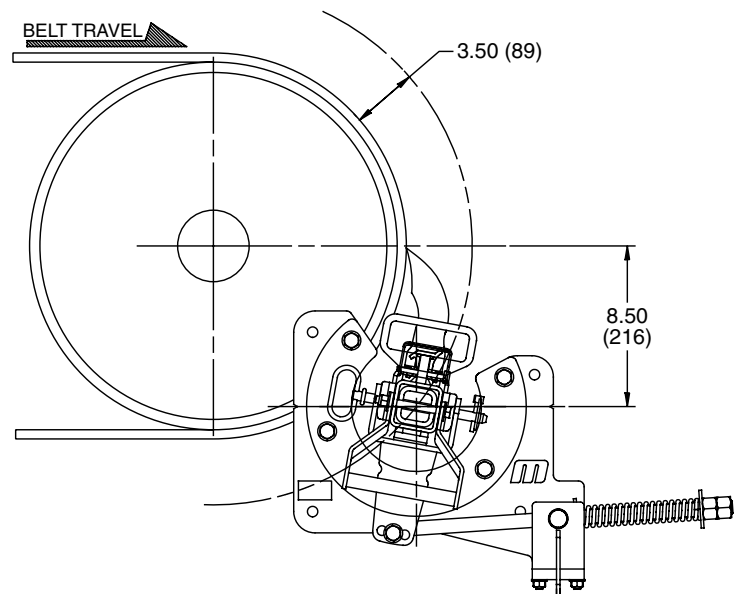

FREQUENTLY ASKED QUESTIONS

My Pre-Cleaner keeps flipping through. What is wrong?
The mounting location may be too far away from the belt. Relocate to the proper mounting location. Replace the mainframe or end weldments if they are bent. Check set screws to determine if they are tight. Retighten if necessary.

My Pre-Cleaner is wearing more in the center of the blade.
The blade is too wide for this application. Replace with a shorter length blade.

TECHNICAL DATA SHEET

MARTIN® AIR TENSIONER HD STS, P/N 39100-HDA

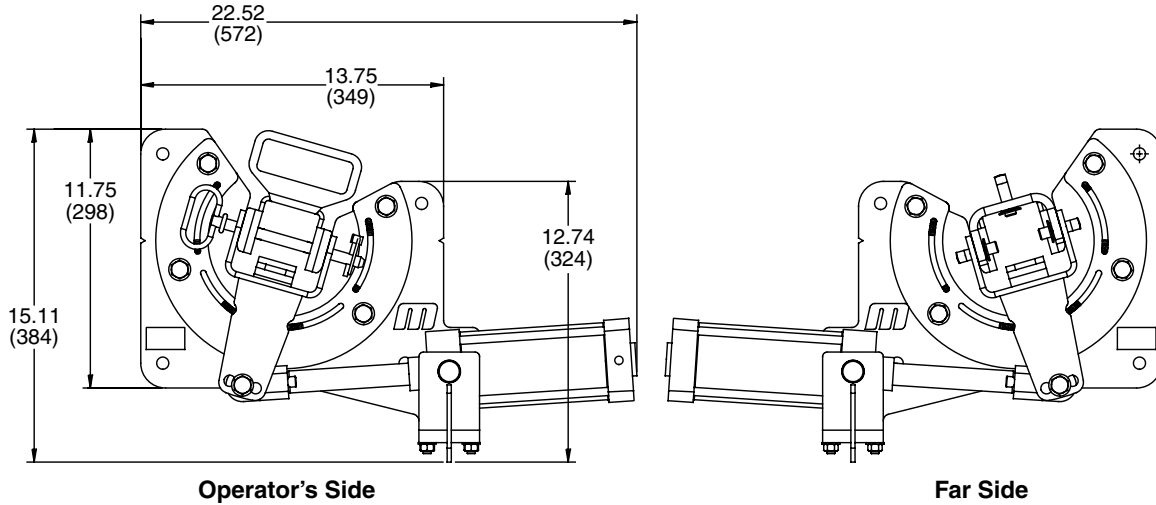

MARTIN® SPRING TENSIONER HD STS, P/N 39100-HDSX

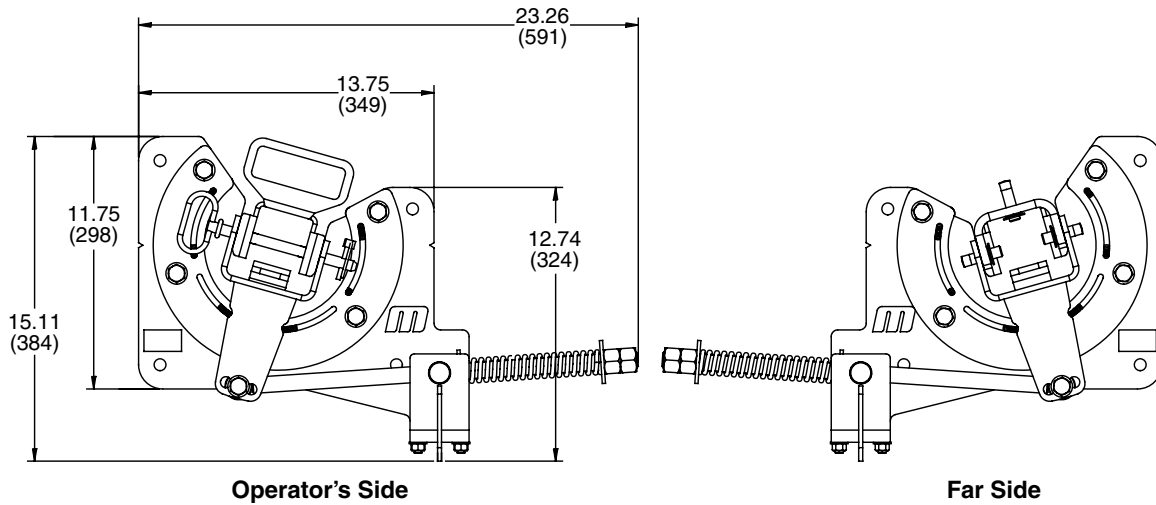

REPLACEMENT BLADE

P/N	P/N Nomenclature	Urethane Options
35381-XX X XX XX	XX = belt width in inches	OR = Orange
	X = option for slits	CL = Tan
	X = option for segments	NB = Navy Blue
	XX = blade width in inches	BR = Brown
	XX = blade color and material	B1 = Black
		GR = Green
		CY = Yellow with Beads



Martin Engineering Australia Pty Ltd.
 102 Christensen Road South
 Stapylton QLD 4207 - Australia
 +61 1300 627 364
 salesau@martin-eng.com | www.martin-eng.com.au

