

Martin® QC1+™ Cleaner PV with Three-Piece Mainframe

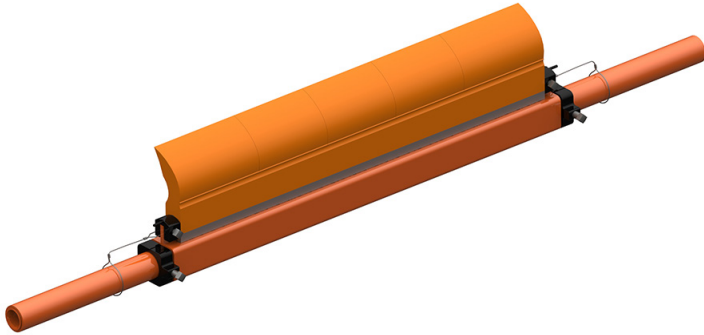

The [Martin® QC1+™ Cleaner PV](#) introduces the next generation of belt cleaning technology.

A truly revolutionary innovation in belt cleaning design, the QC1+™ Cleaner PV provides the cleanest belt and longest blade life— at the lowest cost.

FEATURES & BENEFITS

- Same ease of installation as original Martin® QC1™ Cleaners, maintaining standard installation and service costs.
- Utilizes Martin's highly effective, patented CARP profile, ensuring the highest level of cleaning performance expected from a Martin® Belt Cleaner.

SPECIFICATIONS

Maximum Belt Speed fpm (m/sec)	Maximum Service Temperature	Pulley Diameter in. (mm)	Mounting Location in. (mm)
500 (2.54)	160°F (70°C) Continuous 180°F (82°C) Intermittent	12–16 (300–400)	2.75 (70)

High-performance urethanes are available; see your Martin Engineering representative for assistance in specifying non-standard products. Refer to Form No. L3375.

NOMENCLATURE

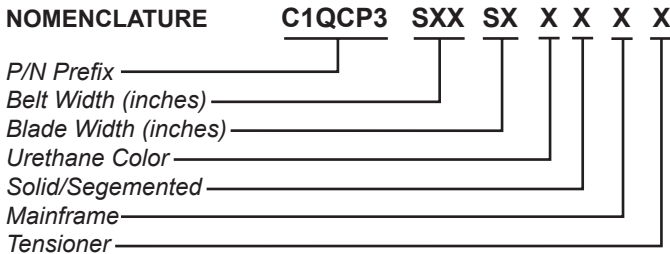

BELT WIDTH

- 000:** No Blade
- SXX:** XX indicates belt width in inches 18 thru 72

BLADE WIDTH

- 00:** No Blade
- S4:** 4 Inches less Belt Width
- S6:** 6 Inches less Belt Width
- S8:** 8 Inches less Belt Width

URETHANE COLOR

- 0:** No Blade
- B:** Brown
- T:** Tan
- G:** Green
- N:** Navy Blue
- O:** Orange

SOLID/SEGMENTED

- 0:** Segmented Blade/No Blade
- 1:** Solid Blade

MAINFRAME

- P:** Painted Steel with Aluminum Blade Insert
- E:** Painted Steel with Extended Torque Tubes
- F:** Stainless Steel
- Z:** Stainless Steel with Extended Torque Tubes
- T:** Painted Steel with Stainless Steel Blade Insert

TENSIONER

- Blank:** No Tensioner
- T:** Martin® Twist Tensioner (P/N 38850)
- F:** Martin® Twist Tensioner (P/N 31443-SS)
- S:** Martin® Spring Tensioner (P/N 38180)
- P:** Martin® Spring Tensioner (P/N 38180-SS)

MOUNTING LOCATION

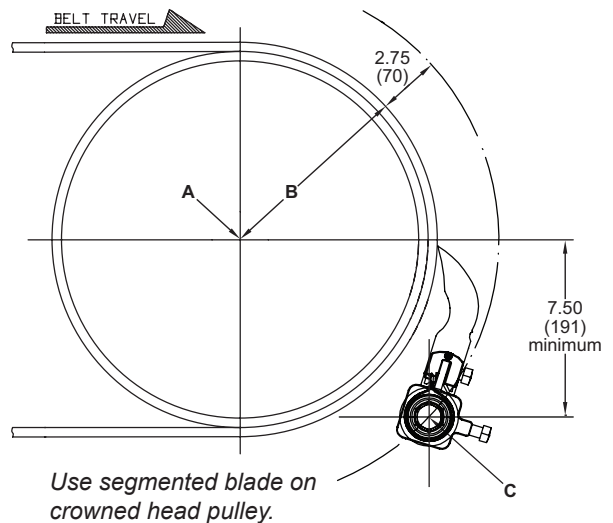

TECHNICAL DATA SHEET

DIMENSIONS -- in. (mm)

Belt Width in. (mm)	Mainframe Length (B) in. (mm)
18 (400-500)	34 (864)
24 (500-650)	46 (1168)
30 (650-800)	52 (1321)
36 (800-1000)	60 (1524)
42 (1000-1200)	72 (1829)

Belt Width in. (mm)	Mainframe Length (B) in. (mm)
48 (1200-1400)	78 (1981)
54 (1400-1600)	84 (2134)
60 (1600-1700)	90 (2286)
66 (1700-1800)	96 (2438)
72 (1800-2000)	102 (2591)

Note: Dimension A equals belt width minus either 4, 6, or 8 inches.
Dual Tensioners are required for belt widths 54 in. (1400 mm) and greater.

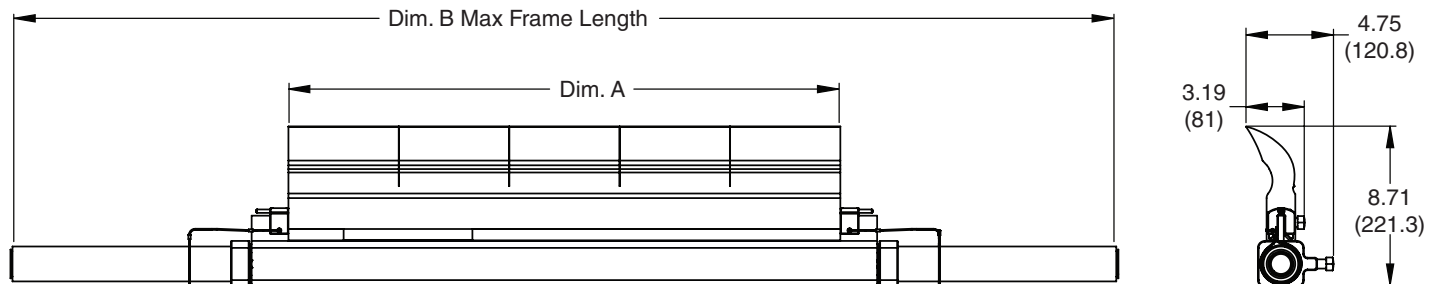

RECOMMENDED TENSIONERS

Tensioner	P/N
Martin® Twist Tensioner–Square	31443
Martin® Twist Tensioner–Round	38850
Martin® Spring Tensioner	38180

ACCESSORIES

Part	P/N
Martin® Steel Inspection Door	CYA-1218
Martin® Hanger Mount Standard Assembly	27382

REPLACEMENT BLADE NOMENCLATURE

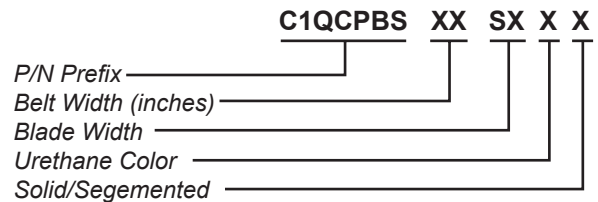

BELT WIDTH

SXX: XX indicates belt width in inches 18 thru 72

BLADE WIDTH

S4: 4 Inches less Belt Width
S6: 6 Inches less Belt Width
S8: 8 Inches less Belt Width

URETHANE COLOR

B: Brown
T: Tan
G: Green
N: Navy Blue
O: Orange

SOLID/SEGMENTED

0: Segmented without Slots
1: Solid without Slots
2: Segmented with Slots
3: Solid with Slots
4: Segmented without Slots & with Blade Holders
5: Solid without Slots & with Blade Holders

FREQUENTLY ASKED QUESTIONS

My Pre-Cleaner keeps flipping through.
The mounting location may be too far away from the belt. Relocate to the proper dimension. Replace the mainframe or end weldments if they are bent.

My Pre-Cleaner is wearing more in the center of the blade.
The blade is too wide for this application. Replace with a shorter length blade.



Martin Engineering Australia Pty Ltd.
102 Christensen Road South
Stapylton QLD 4207 - Australia
+61 1300 627 364
salesau@martin-eng.com | www.martin-eng.com.au

