

N2[®] Position Indicator

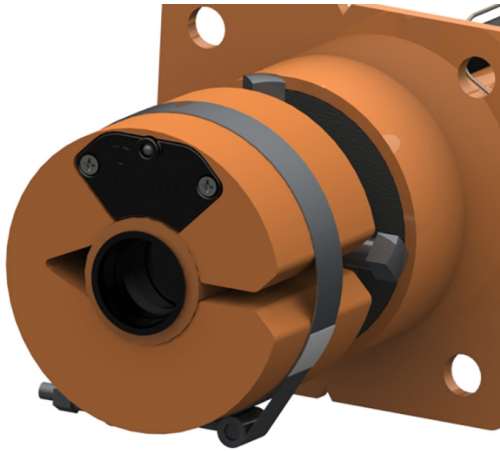

The intuitive **N2[®] Position Indicator** remotely monitors the position of the belt cleaner blade, allowing for estimation of blade life, notification when re-tensioning or replacement is required, and warning in the event of an abnormal condition.

The N2[®] Gateway receives information from up to 200 N2[®] Position Indicators and transmits information to the cloud for monitoring via the Martin[®] Smart Device Manager mobile application.

N2[®] POSITION INDICATOR ACCESSORIES

Part Number	Description
EC1SQCHP1007	HD/PV Adapter Assembly
EG10062	Magnet Reset Tool

BENEFITS

- Know when blade change is required
- Know when to re-tension
- Know when the blade is not in contact with the belt
- Know when an abnormal condition is present
- Warning of any substantial change in temperature
- 1–2 year battery life from lithium ion AA batteries

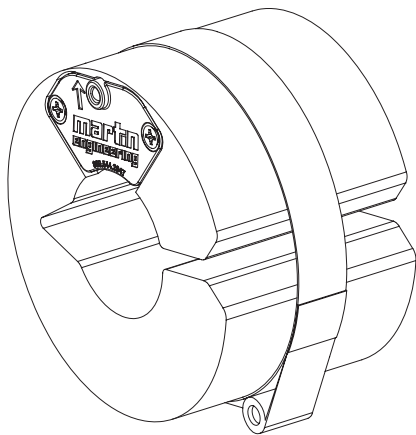

N2[®] POSITION INDICATOR FOR HD AND PV CLEANERS

NOMENCLATURE EC1SQCH1S XX XX XX X

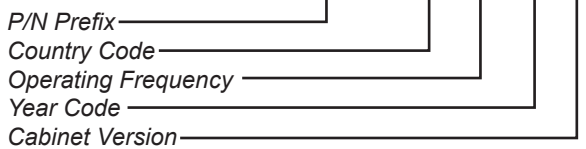

COUNTRY CODE
US: United States

YEAR CODE
20: 2020

OPERATING FREQUENCY
02: 915 MHz

CABINET VERSION
1: Version 1

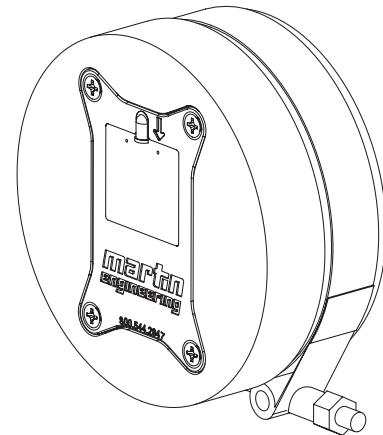

N2[®] POSITION INDICATOR FOR XHD CLEANERS

NOMENCLATURE EC1SQCE1S XX XX XX X

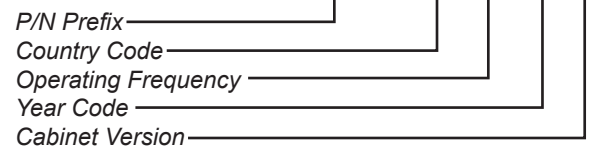

COUNTRY CODE
US: United States

YEAR CODE
20: 2020

OPERATING FREQUENCY
02: 915 MHz

CABINET VERSION
1: Version 1

TECHNICAL DATA SHEET

DIMENSIONS

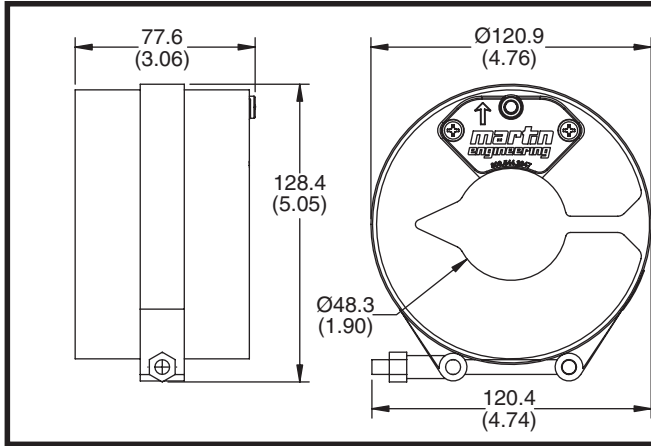

N2® POSITION INDICATOR FOR HD AND PV CLEANERS

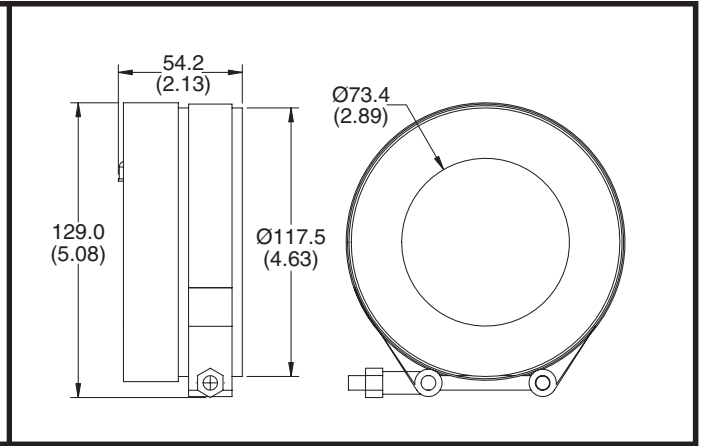

N2® POSITION INDICATOR FOR XHD CLEANERS

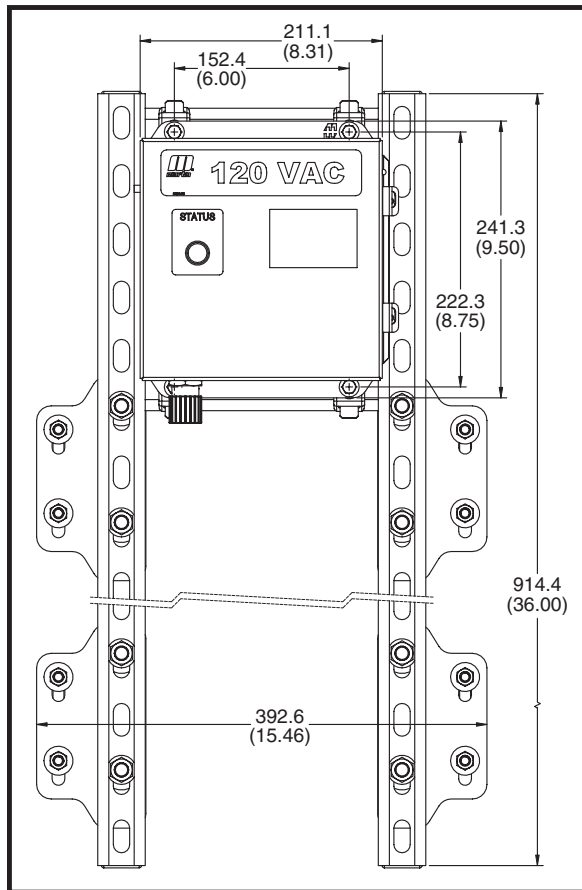

N2® GATEWAY

N2® GATEWAY

NOMENCLATURE EGC006 XX XX XX XX X

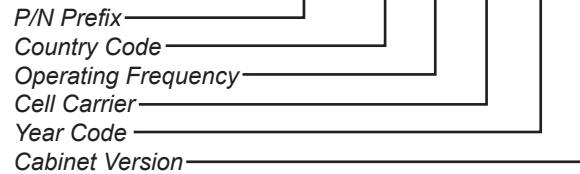

COUNTRY CODE

US: United States

YEAR CODE

20: 2020

OPERATING FREQUENCY

01: 915 MHz
03: 915 MHz & 2.4GHz

CABINET VERSION

1: Version 1

CELL CARRIER

00: No Cell Carrier
VZ: Verizon

N2® GATEWAY SPECIFICATIONS

Power Supply	Power Consumption	Service Temperature Range
50/60Hz 100-240VAC	0.75 Amps	-30° to 60°C (-22° to 140°F)



Martin Engineering Australia Pty Ltd.

102 Christensen Road South
Stapylton QLD 4207 - Australia

+61 1300 627 364

salesau@martin-eng.com | www.martin-eng.com.au

**COMPANY WITH
QUALITY SYSTEM
CERTIFIED BY DNV GL
= ISO 9001 =**