

Martin® Gate Jack Opener



Eliminate strong-arm tactics with the [Martin® Gate Jack Opener](#). This powerful air-powered wrench provides more than 1750 ft-lb (2373 N•m) of torque to open the most stubborn rack and pinion hopper gate.

BENEFITS

- Improves Unloading Efficiency**
 Stop the car, open the gate, and start unloading. There's no time wasted trying to muscle the gate open.
- One-Worker Operation**
 No need for labor gangs or cheater bars with the compact, powerful Martin® Gate Jack Opener.
- Efficient Air Use**
 Operates from air supply of 70 cfm (1982 L/min) at 80 to 125 psi (5.5 to 8.6 bar).
- Readily Portable**
 Martin® Gate Jack Opener only weighs 65 lb (29.5 kg) for easy positioning and use by one worker.
- Easy to Apply**
 Capstan extension reaches even "hard-to-get-at" recessed railcar capstans.
- Comes Complete**
 Supplied with hoses and hand-held control valve. Customer must supply own steel "lever" bar.

SPECIFICATIONS

| | |
|---------------------|---|
| Air Pressure | 70 cfm at 80—125 psi (1982 L/min at 5.5—8.6 bar) |
| Output | above 1750 ft-lb (2373 N•m) |
| Weight | 65 lb (29.5 kg) |
| Part Number | M90 |

REPLACEMENT PARTS

| Part Number | Description |
|-------------|----------------------|
| 30913-06 | Air Motor Repair Kit |

TECHNICAL DATA SHEET

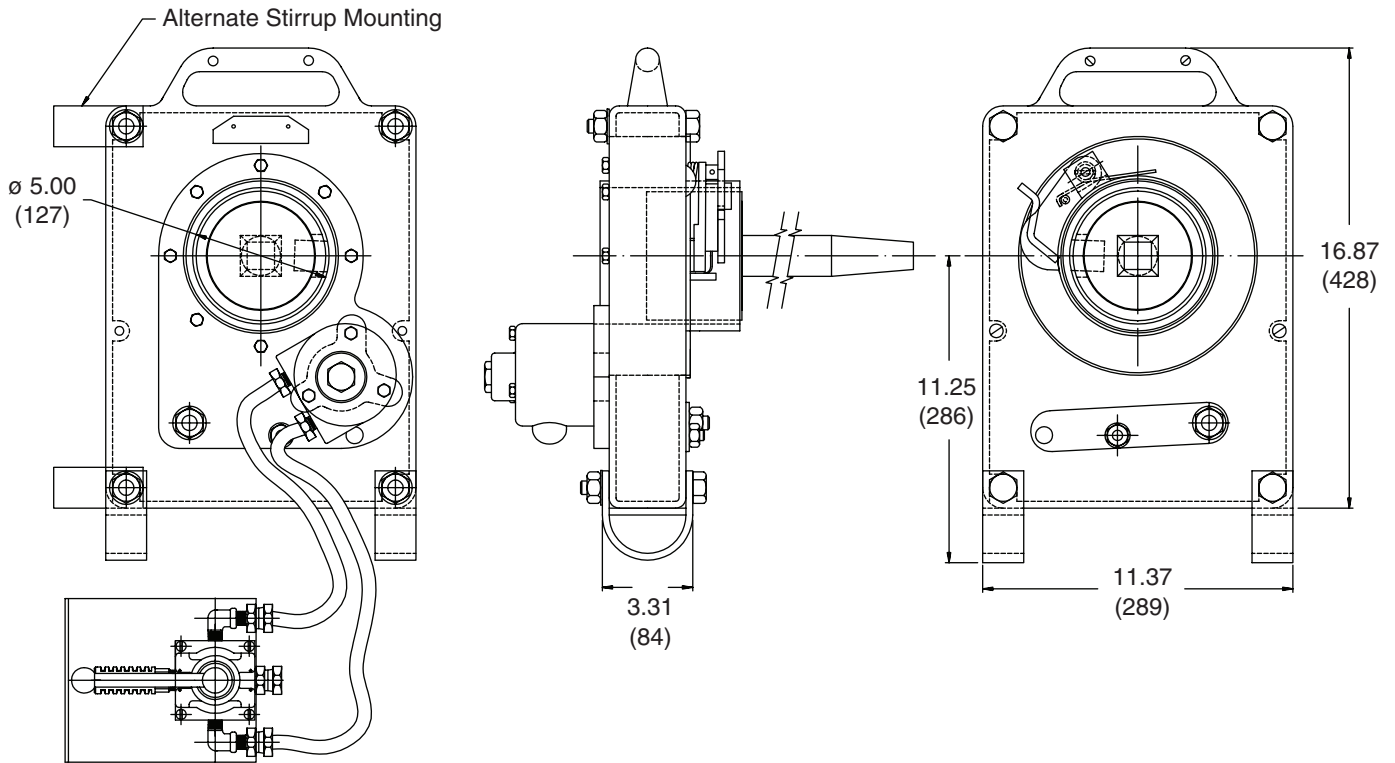

Martin Engineering Australia Pty Ltd.
20 Ern Harley Dr - Burleigh Heads, QLD, 4220 - Australia
1300 627 364
www.martin-eng.com.au

