

Martin® DT2S Reversing Cleaner

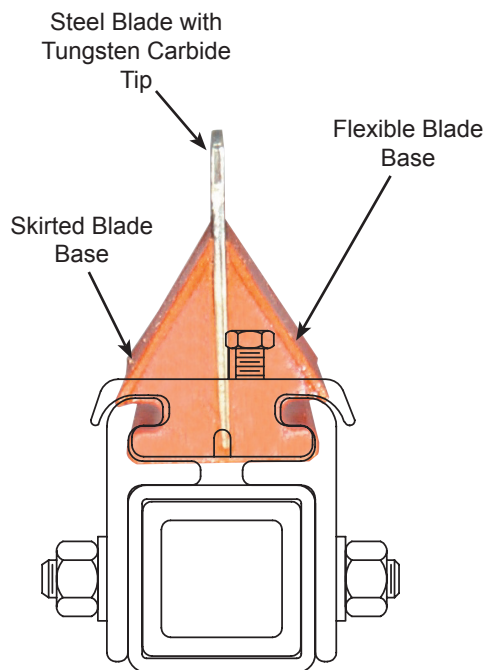

Combining the best features of two successful Martin Engineering Secondary Cleaners, the [Martin® DT2S Reversing Cleaner](#) features a split-track blade cartridge that slides in and out on a stainless steel mandrel. This unique engineering makes for a fast and easy service procedure to reduce conveyor downtime.



BENEFITS

- Removes Carryback, Saves Cleanup**
 Effective belt cleaning reduces plant clean-up chores, and prolongs life of conveying equipment.
- 5-Minute Blade Change**
 Blades slide into split-frame cartridge; cartridge slides into cleaning position on stainless steel mandrel.
- Minimizes Service Time**
 Slide-in/slide-out blade cartridge allows quick and easy blade service that minimizes conveyor downtime. Even when the cleaner is encrusted with material, one-half of the split frame can be removed to allow blade change. With on-site safety approvals, blades can be changed while the belt runs.
- Installs in Small Places**
 Lean profile minimizes space requirements, allows installation in spaces as narrow as seven inches (178 mm).
- Suitable for Reversing Belts**
 Can be installed on conveyors that roll back or run in two directions.

Martin® DT2S REPLACEMENT BLADES

Martin® DT2S Reversing Blade	P/N
Tungsten Carbide	31104 - T
Urethane	31104 - U
Stainless Steel	31104 - S
Mild Steel	31104 - M
Tungsten Carbide with Stainless Steel Holder	31104 - TCS

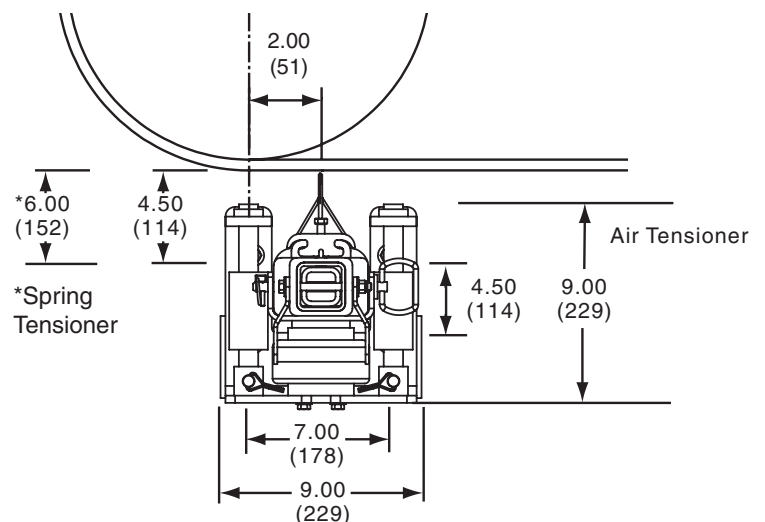

TECHNICAL DATA SHEET

* Metric belt widths are given as standard industry belt sizes rather than conversions.

DIMENSIONS – in. (mm)

Belt Width* in. (mm)	No. of Blades	Blade Coverage in. (mm)	Max. Mainframe Length in. (mm)	Weight w/o Tensioner lb (kg)	Assembly P/N with Tensioner**
24 (500-650)	4	24 (210)	56 (1422)	62 (30)	DT2S-24XXXXXXXX
	3	18 (457)		70 (32)	
30 (650-800)	5	30 (762)	62 (1575)	72 (33)	DT2S-30XXXXXXXX
	4	24 (610)		79 (36)	
36 (800-1000)	6	36 (914)	68 (1727)	89 (40)	DT2S-36XXXXXXXX
	5	30 (792)		82 (37)	
42 (1000-1200)	7	42 (1067)	74 (1880)	99 (45)	DT2S-42XXXXXXXX
	6	36 (914)		92 (42)	
48 (1200-1400)	8	48 (1219)	80 (2032)	110 (50)	DT2S-48XXXXXXXX
	7	42 (1067)		102 (46)	
54 (1400-1600)	9	54 (1372)	84 (2134)	120 (55)	DT2S-54XXXXXXXX
	8	48 (1219)		112 (51)	
60 (1600-1800)	10	60 (1524)	90 (2286)	130 (60)	DT2S-60XXXXXXXX
	9	54 (1372)		122 (56)	
66 (1650-1750)	11	66 (1676)	96 (2438)	140 (64)	DT2S-66XXXXXXXX
	10	60 (1524)		133 (61)	
72 (1800-2000)	12	72 (1829)	104 (2642)	152 (69)	DT2S-72XXXXXXXX
	11	66 (1676)		143 (65)	
84 (2000-2200)	14	84 (2134)	116 (2946)	172 (78)	DT2S-84XXXXXXXX
	13	78 (1981)		163 (74)	
96 (2200-2400)	16	96 (2438)	128 (3251)	189 (86)	DT2S-96XXXXXXXX
	15	90 (2286)		183 (82)	

NOMENCLATURE

DT2S-XX X XXXX X X

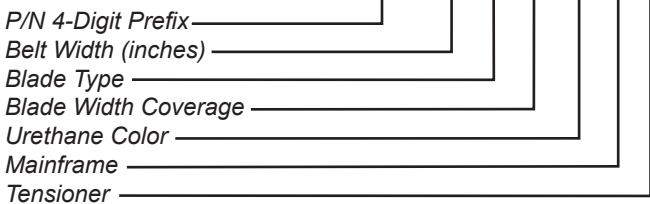

Blade Type

- R:** Tungsten Carbide Insert with Stainless Steel Holder
- T:** Tungsten Carbide Reversing Blade
- S:** Stainless Steel Reversing Blade
- U:** Urethane Reversing Blade
- M:** Mild Steel Reversing Blade

Mainframe

- P:** Standard Duty
- S:** 316 Stainless Steel

Urethane Color

- BR:** Brown
- GR:** Green
- OR:** Orange

Tensioner Type

- A:** Air Tensioner
- S:** Spring Tensioner

Spring Tensioners

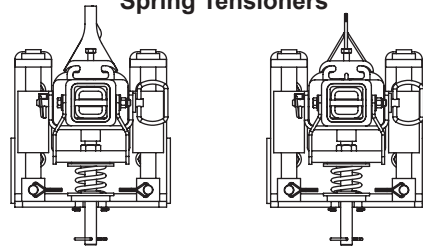

Air Tensioners

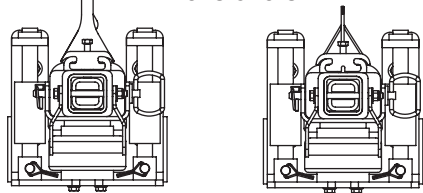

Martin Engineering USA

102 Christensen Road South
 Stapylton QLD 4207 - Australia
 +61 1300 627 364
 salesau@martin-eng.com | www.martin-eng.com.au

**COMPANY WITH
 QUALITY SYSTEM
 CERTIFIED BY DNV
 = ISO 9001:2008 =**

Problem Solved™ GUARANTEED!

Form No. L3685-02/20
 © Martin Engineering Company 2002, 2020