

Martin® Compact Cleaner



The [Martin® Compact Cleaner](#) from Martin Engineering uses a low-profile blade mounted on an internal square mainframe for effective belt cleaning in tight spaces. It is designed for applications on small pulleys and belts operating at speeds up to 350 fpm (1.78 m/sec).

BENEFITS

- Fits In Smallest Spaces**
 Fits in spaces with as little as 6.75 inches (171 mm) of clearance on pulleys as small as 7.00 inches (180 mm) in diameter.
- Curved Blade Sustains Performance**
 Blade incorporates patented Continuous Angle Radial Pressure (CARP) design to maintain effective cleaning across blade life.
- Simple Blade Service**
 To replace worn blade, slide new blade onto square tube mainframe.
- Choose Segments**
 Segments allow one-piece blade to accommodate crowned pulleys and variations in belt travel.
- Urethane Options Match Needs**
 Blades are available in high-performance urethane “colors” to match application requirements.
High-performance urethanes are available; see your Martin Engineering representative for assistance in specifying nonstandard products. Refer to Form No. L3375.

NOMENCLATURE

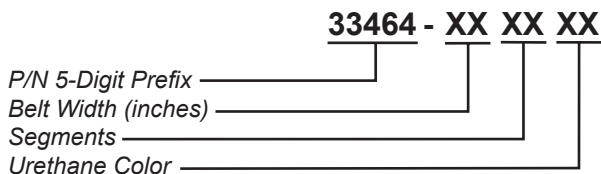

SEGMENTS

- 10 with segments
- 11 without segments

URETHANE COLOR

- BR for Brown
- GR for Green
- NB for Navy Blue
- CL for Tan
- Blank for Orange

SPECIFICATIONS

Belt Cleaner	Max. Belt Speed fpm (m/sec)	Maximum Service Temp. °F (°C)	Min Pulley Diameter in. (mm)	Mounting Distance in. (mm)
Martin® Compact Cleaner	350 (1.78)	160 (71) Continuous 180 (82.2) Intermittent	6.0 (152.4)	1.75 (44.5)

TECHNICAL DATA SHEET

DIMENSIONS

Belt Width in. (mm)*	Mainframe Length in. (mm) A	Blade Coverage in. (mm) B	Shipping Weight lb (kg)	Assembly P/N
12 (305)	28 (711)	10 (254)	12 (5.44)	33464-12XXXX
14 (356)	30 (762)	12 (305)	14 (6.35)	33464-14XXXX
16 (406)	31 (787)	14 (356)	15 (6.80)	33464-16XXXX
18 (457)	32 (813)	16 (406)	16 (7.26)	33464-18XXXX
24 (610)	40 (1016)	22 (559)	25 (11.34)	33464-24XXXX
30 (762)	44 (1118)	28 (711)	27 (12.25)	33464-30XXXX
36 (914)	52 (1321)	34 (864)	30 (13.61)	33464-36XXXX
42 (1067)	56 (1422)	40 (1016)	33 (14.97)	33464-42XXXX
45 (1143)	60 (1524)	43 (1092)	33 (14.97)	33464-45XXXX
48 (1219)	64 (1626)	46 (1168)	33 (14.97)	33464-48XXXX

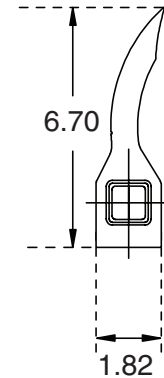

*Metric measurements represent a conversion of belt width in inches rather than a standard metric belt size.

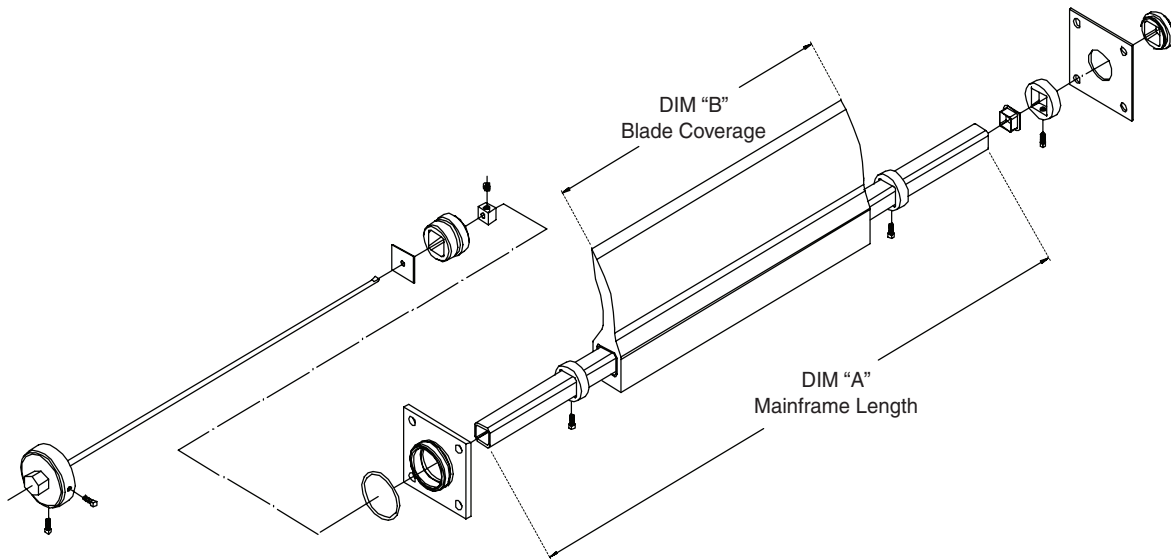

Belt Cleaner	Tensioner	Tensioner P/N	Replacement Blade P/N
Martin® Compact Cleaner	Martin® Internal Spring Tensioner	33036	33463-XXXXXX



Martin Engineering Australia Pty Ltd.
 102 Christensen Road South
 Stapylton QLD 4207 - Australia
 +61 1300 627 364
 salesau@martin-eng.com | www.martin-eng.com.au

