

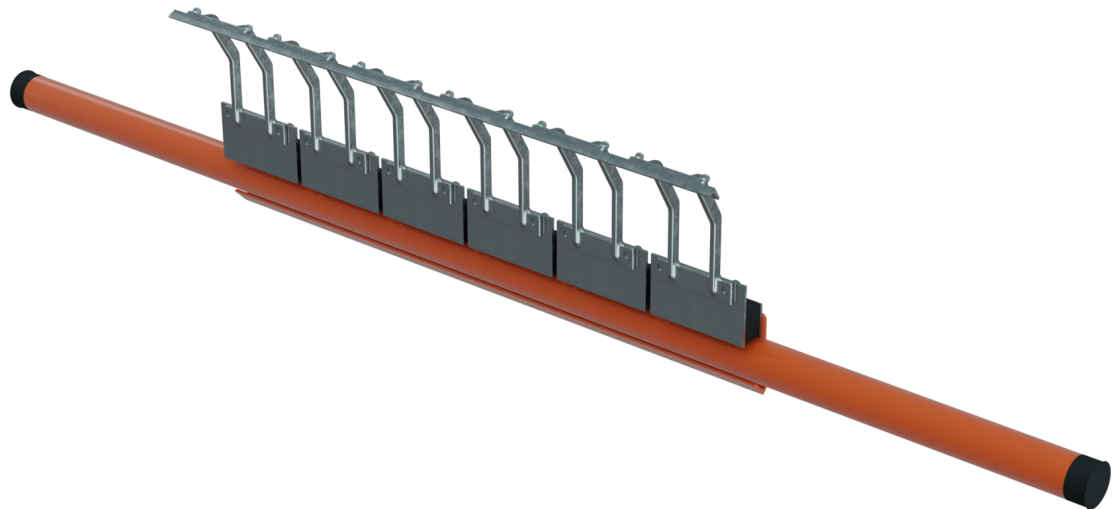

# **Martin<sup>®</sup> H1 Primary Belt Cleaner HD**

[Go to Martin<sup>®</sup> H1 Primary Belt Cleaner HD web page](#)



***Operator's Manual***  
***M4226***

# Important

MARTIN ENGINEERING HEREBY DISCLAIMS ANY LIABILITY FOR: DAMAGE DUE TO CONTAMINATION OF THE MATERIAL; USER'S FAILURE TO INSPECT, MAINTAIN AND TAKE REASONABLE CARE OF THE EQUIPMENT; INJURIES OR DAMAGE RESULTING FROM USE OR APPLICATION OF THIS PRODUCT CONTRARY TO INSTRUCTIONS AND SPECIFICATIONS CONTAINED HEREIN. MARTIN ENGINEERING'S LIABILITY SHALL BE LIMITED TO REPAIR OR REPLACEMENT OF EQUIPMENT SHOWN TO BE DEFECTIVE.

Observe all safety rules given herein along with owner and Government standards and regulations. Know and understand lockout/tagout procedures as defined by American National Standards Institute (ANSI) ANSI/ASSP z244.1-2024, *The Control of Hazardous Energy Lockout, Tagout And Alternative Methods and Occupational Safety* and Health Administration (OSHA) Federal Register, Title 29 Subtitle B Chapter XVII Subpart J 1910.147, *Control of Hazardous Energy Source (Lockout/Tagout)*; Final Rule.

The following symbols may be used in this manual:



**Danger:** Immediate hazards that will result in severe personal injury or death.



**Warning:** Hazards or unsafe practices that could result in personal injury.



**Caution:** Hazards or unsafe practices that could result in product or property damages.



**Important:** Instructions that must be followed to ensure proper installation/operation of equipment.



**Note:** General statements to assist the reader.

# Table of Contents

Section	Page
List of Figures and Tables .....	ii
Introduction .....	1
General .....	1
Installations without chutework .....	1
Belt cleaner inspection access .....	1
Belt cleaner tips .....	1
References .....	1
Materials required .....	1
Safety .....	2
Before Installing Belt Cleaner .....	3
Installing Belt Cleaner and Tensioner .....	4
Locating belt cleaner mainframe .....	4
Method 1: (X, C & Y Dimensions) .....	5
Method 1: (X, C & Y Dimensions) with obstructions .....	5
Method 2: (Y, Z & C Dimensions) .....	7
Method 2: (Y, Z & C Dimensions) with obstructions .....	7
Installing tensioner .....	9
Mainframe installation .....	10
Tip tension and adjustment .....	11
After Installing Belt Cleaner .....	15
Maintenance .....	16
Visual inspection .....	16
Physical inspection .....	16
Arm / buffer / tips service instructions .....	17
Troubleshooting .....	19
Part Numbers .....	20

## List of Figures

Figure	Title	Page
1	Martin® H1 Primary Belt Cleaner HD Method 1 Mainframe Coordinate Dimensions .....	5
2	Martin® H1 Primary Belt Cleaner HD Method 1 Obstructed Mainframe Suitable Locations ...	6
3	Martin® H1 Primary Belt Cleaner HD Method 2 Mainframe Coordinate Dimensions .....	7
4	Martin® H1 Primary Belt Cleaner HD Method 2 Obstructed Mainframe Suitable Locations ...	8
5	Martin® H1 Primary Belt Cleaner HD Chute Cutout Details .....	9
6	Martin® H1 Primary Belt Cleaner HD Mainframe Installation .....	10
7	Martin® H1 Primary Belt Cleaner HD Adjuster Arm .....	10
8	Martin® H1 Primary Belt Cleaner HD Tip Contact .....	10
9	Martin® H1 Primary Belt Cleaner HD Shimming .....	11
10	Martin® H1 Primary Belt Cleaner HD Tip Alignment .....	12
11	Martin® H1 Primary Belt Cleaner HD Tip Angle Gauge .....	13
12	Martin® H1 Primary Belt Cleaner HD Tensioner Adjustment Hardware .....	14
13	Martin® H1 Primary Belt Cleaner HD Arm, Buffer, Tip Installation .....	17
14	Martin® H1 Primary Belt Cleaner HD, P/N C1HXXXXXXXXXXXXXX .....	21
15	Conveyor Products Warning Label, P/N 23395 .....	24

## List of Tables

Table	Title	Page
I	Martin® H1 Primary Belt Cleaner HD Arm Size Specifications .....	4
II	Martin® H1 Primary Belt Cleaner HD Coordinate Chart .....	8
III	Martin® H1 Primary Belt Cleaner HD Operator Side Chute Cutout Details .....	9
IV-A	Martin® H1 Primary Belt Cleaner HD Mainframe Part Numbers and Quantities .....	22
IV-B	Martin® H1 Primary Belt Cleaner HD Extended Mainframe Part Numbers .....	22
V	Martin® H1 Primary Belt Cleaner HD Buffer Part Numbers .....	22
VI	Martin® H1 Primary Belt Cleaner HD Arm Part Numbers .....	23
VII	Martin® H1 Primary Belt Cleaner HD Tip Part Numbers .....	23
VIII	Martin® H1 Primary Belt Cleaner HD Tensioner Part Numbers .....	23
IX	Martin® Spring Tensioner Part Numbers .....	23

# Introduction

---

## ***General***

Martin Engineering's H1 Primary Belt Cleaner HD is a robust, durable, and highly effective conveyor belt cleaning system. Built with precision cast stainless steel components and abrasion resistant tungsten carbide tips, it offers one of the most cost efficient cleaning solutions in the industry.

Designed to efficiently remove carryback, it is suitable for most material types, with tungsten carbide tips delivering exceptional performance, particularly when cleaning abrasive materials or operating on high speed conveyor belts.

However, tungsten carbide tips are not recommended for conveyor belts equipped with mechanical fasteners or belts with significant cover damage.

## ***Installations without chutework***

These procedures were written for equipment that is being installed on enclosed pulley chutework. If the pulley is not enclosed, the equipment should be installed using the best available field resources and methods to ensure that the critical dimensions are followed for proper installation.

## ***Belt cleaner inspection access***

If the belt cleaner is installed on enclosed pulley chutework, at least one Martin® Inspection Door should be installed. Martin® Inspection Doors are available from Martin Engineering or a representative.

## ***Belt cleaner tips***

Martin® H1 Primary Belt Cleaner HD Tips are available in 10X3 and HD 15X5 configurations.

## ***References***

The following documents are referenced in this manual:

- American National Standards Institute (ANSI) z244.1-1982, *American National Standard for Personnel Protection - Lockout/Tagout of Energy Sources - Minimum Safety Requirements*, American National Standards Institute Inc., 1430 Broadway, New York, NY 10018.
- Federal Register, Volume 54, Number 169, Part IV, 29 CFR Part 1910, *Control of Hazardous Energy Source (Lockout/Tagout); Final Rule*, Department of Labor, Occupational Safety and Health Administration (OSHA), 32nd Floor, Room 3244, 230 South Dearborn Street, Chicago, IL 60604.

## ***Materials required***

Installation of this equipment requires the use of standard hand tools, grinder, welder, and cutting torch.

## Safety

All safety rules defined in the above documents and all owner/employer safety rules must be strictly followed when working on the belt cleaner.

**⚠ DANGER**

Do not touch or go near the conveyor belt or conveyor accessories when the belt is running. Your body or clothing can get caught and you can be pulled into the conveyor, resulting in severe injury or death.

**⚠ DANGER**

Before installing, servicing, or adjusting the belt cleaner, turn off and lockout / tagout / blockout / testout all energy sources to the conveyor and conveyor accessories according to ANSI standards or country specific safety standards (DIN, ISO, etc.). Failure to do so could result in serious injury or death.

**⚠ DANGER**

If this equipment will be installed in an enclosed area, test the gas level or dust content before using a cutting torch or welding. Using a torch or welding in an area with gas or dust may cause an explosion resulting in serious injury or death. Follow local and customer confined space procedures.

**⚠ WARNING**

Before using a cutting torch or welding the chute wall, cover the conveyor belt with a fire retardant cover. Failure to do so can allow the belt to catch fire. Follow local and customer fire watch procedures

**⚠ WARNING**

Remove all tools from the installation area and conveyor belt before turning on the conveyor. Failure to do so can cause serious injury to personnel or damage to the belt and conveyor.

**⚠ WARNING**

Mainframe with tips can be heavy and may require two people to lift. Attempting to lift the belt cleaner without assistance could result in injury.

# Before Installing Belt Cleaner

## IMPORTANT

**The delivery service is responsible for damage occurring in transit. Martin Engineering CANNOT enter claims for damages. Contact your transportation agent for more information.**

1. Inspect shipping container for damage. Report damage to delivery service immediately and fill out delivery service’s claim form. Keep any damaged goods subject to examination.
2. Remove belt cleaner assembly from shipping container.
3. If anything is missing contact Martin Engineering or a representative.

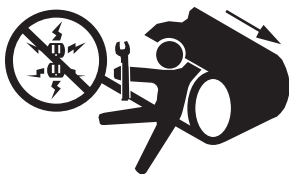

## ⚠ DANGER

**Before installing the belt cleaner, turn off and lockout / tagout / blockout / testout all energy sources to the conveyor and conveyor accessories according to ANSI standards or country specific safety standards (DIN, ISO, etc.). Failure to do so could result in serious injury or death.**

4. Turn off and lockout / tagout / blockout / testout energy source according to ANSI standards or country specific safety standards (DIN, ISO, etc.) (see “References”)



## ⚠ DANGER

**If this equipment will be installed in an enclosed area, test the gas level or dust content before using a cutting torch or welding. Using a torch or welding in an area with gas or dust may cause an explosion resulting in serious injury or death. Follow local and customer confined space procedures.**

5. If using a cutting torch or welding, test atmosphere for gas level or dust content. Cover conveyor belt with fire retardant cover. Follow local fire watch procedures.

## IMPORTANT

**Center the belt cleaner tips to clean an area narrower than the conveyor belt width. This allows for side-to-side movement of the belt and prevents damage to the belt edge.**

## NOTE

**The chute wall that the tensioner will be located on is referred to as the “operator side.” The other side of the chute is referred to as the “far side.” (If installing dual tensioners, side that is most accessible is “operator side.”)**

6. Determine which side of chute is easiest to access. Locate the operator side tensioner on the most accessible chute wall and the far side tensioner on the other side of the chute.

# Installing Belt Cleaner and Tensioner

## IMPORTANT

### Read entire section before beginning work

To install the belt cleaner, follow the procedures corresponding to the following steps:

### *Locating belt cleaner mainframe center*

1. Inspect belt cleaner mounting area for possible obstructions that could interfere with proper mounting. Refer to the following guidelines:
  - a. The cleaner should be mounted at the recommended 15 degrees below the horizontal plane of the head pulley as long as:
    - (1) The tip is not in the direct flow of discharging material causing premature tip wear.
    - (2) The diameter of the pulley is big enough that the cleaner does not trap or hold material between the inside of the cleaner and the belt.
    - (3) Ensure that the correct arm is selected based on the diameter of the pulley, including pulley lagging and belt thickness. (Refer to Table I.)
  - b. Lack of service is the main cause of poor belt cleaning performance. Follow CEMA guidelines for access:
    - (1) Clearance for service outside the chute must be at least equal to the belt width.
    - (2) Cleaners must have service platforms. CEMA recommends cleaners be mounted at least 600 mm (24 in.) above the work platform.
    - (3) If the belt width is 1400 mm (54 in.) or larger consider access doors on both sides of the chute.
2. Confirm arm size selection based on pulley diameters from Table 1.

**Table I. Martin® H1 Primary Belt Cleaner HD Arm Size Specifications**

<b>Pulley Diameter including Lagging &amp; Belt Thickness - mm (in.)</b>	<b>Recommended Arm Size</b>
250-500 (10-20)	SS
500-800 (20-31)	S
800-1000 (31-39)	M
1000-1200 (39-47)	L
1200-1700 (47-67)	LL

3. To determine the correct location for the mainframe, calculate the position using the dimensions given for the corresponding arm and mainframe size for any of the methods below (Refer to Figure 1.)
  - a. Method 1 - Location of the belt cleaner mainframe center using “X”, “C”, and “Y” dimensions.
  - b. Method 2 - Location of the belt cleaner mainframe center using “Y”, “Z”, and “C” dimensions.

If obstructions are present and the mainframe must be relocated, follow *Method 1: (“X”, “C” & “Y” Dimensions) with obstruction (Pg 5)* or *Method 2: (“Y”, “Z” & “C” Dimensions) with obstruction (Pg 6)*.

**Method 1:  
(X, C & Y  
Dimensions)**

- (1) Locate dimension “X” from the Table II or alternately locate dimension “C” from Table II based on pulley diameter. (Including belt and lagging thickness)
- (2) Using dimension “X” measured from the belt surface, or dimension “C” measured from the pulley shaft center, mark arc “C” on the chute wall.
- (3) Draw a horizontal reference line which is parallel with the conveyor stringer through the center line of the pulley shaft.
- (4) From the same reference line drawn in step 3, measure down distance “Y” to where “Y” intersects on the arc “C” drawn in step 2.
- (5) This is the optimal center point for the mainframe. The cleaner tip should be no more than  $15^{\circ} \pm 5^{\circ}$  to the horizontal reference line drawn in step 3.
- (6) The location of the mainframe center can be verified by measuring along the reference line a distance ‘Z’. This point should overlap the Y dimension line that intersects arc “C”.

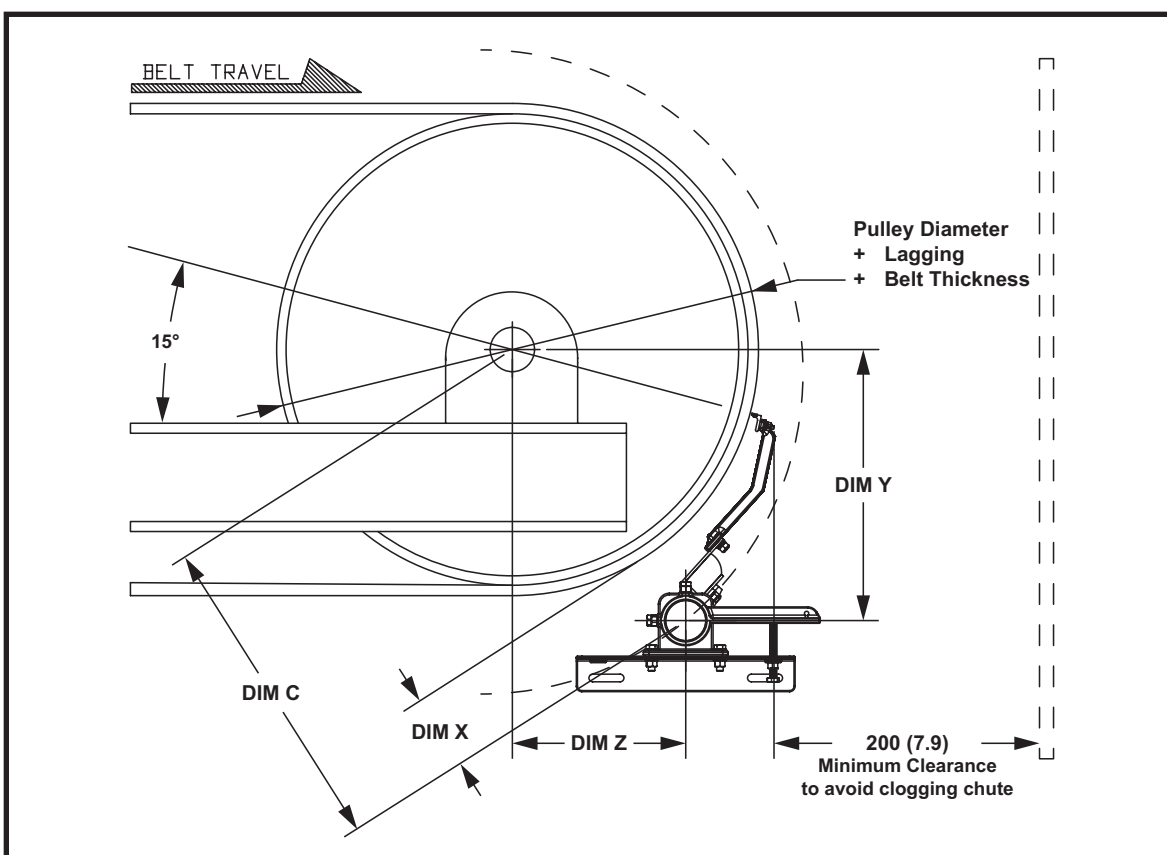

**Figure 1. Martin® H1 Primary Belt Cleaner HD Method 1  
Mainframe Coordinate Dimensions**

**Method 1:  
(X, C & Y  
Dimensions) with  
obstruction**

- (1) Follow steps 1 through 4 from *Method 1:(X, C & Y Dimensions)*.
- (2) Move the mainframe center location point along the arc “C” until a suitable location point is found away from the obstruction. Take care to avoid going past the 3 or 6 O’ Clock position. (Refer to Figure 2.)

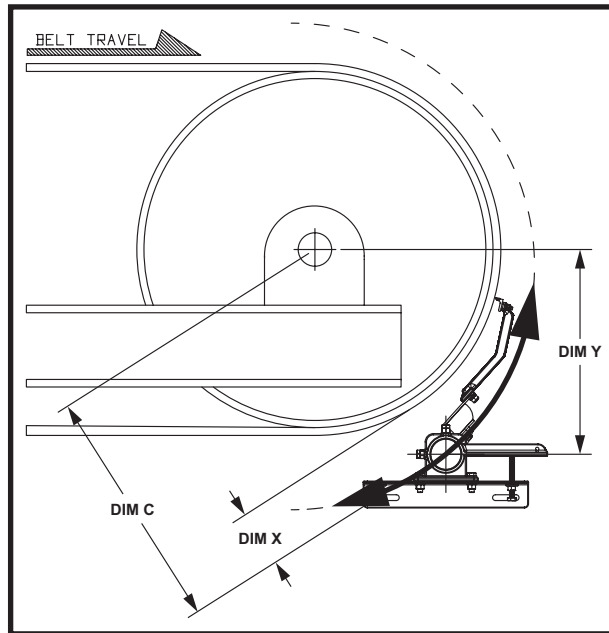

**Figure 2. Martin® H1 Primary Belt Cleaner HD Method 1  
Obstructed Mainframe Suitable Locations**

**Method 2:  
(Y, Z & C  
Dimensions)**

- (1) Locate dimension “Y” and dimension “Z” from Table II based on pulley diameter. (Including belt and lagging thickness)
- (2) Draw a horizontal reference line which is parallel with the conveyor stringer through the center line of the pulley shaft.
- (3) On the same reference line drawn in step 2, measure distance “Z” from the pulley shaft center. Mark this point “Z”.
- (4) At point “Z”, measure distance “Y” down perpendicular from the reference line. Mark this point.
- (5) This is the optimal center point for the mainframe. The cleaner tip should be no more than 15° +/-5° to the horizontal reference line drawn in step 2.
- (6) The location of the mainframe can be verified by using dimension “C” from Table II to confirm the distance from the pulley shaft center to the center location of the mainframe.

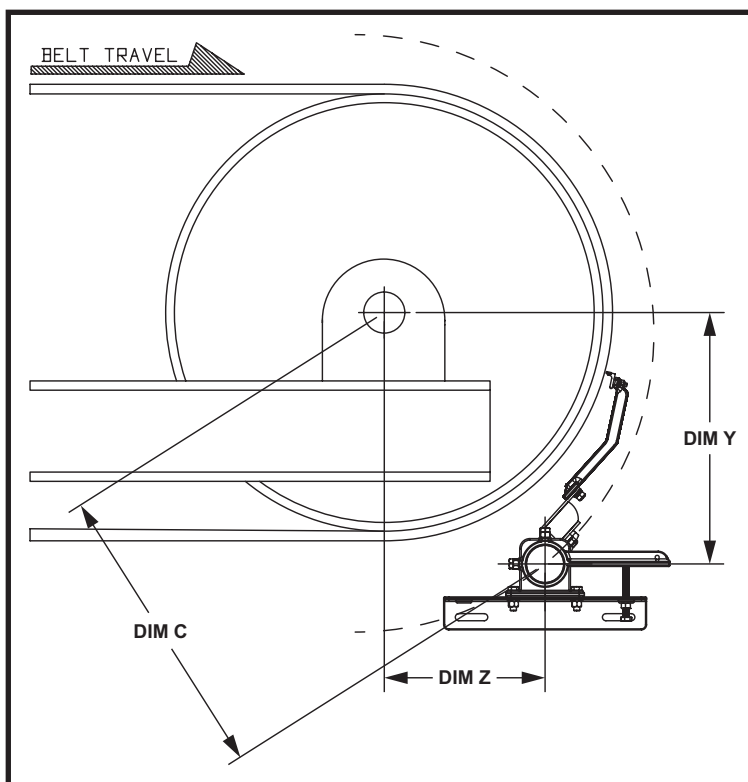

**Figure 3. Martin® H1 Primary Belt Cleaner HD Method 2  
Mainframe Coordinate Dimension**

**Method 2:  
(Y, Z & C  
Dimensions) with  
obstruction**

- (1) Follow steps 1 through 4 from *Method 2:(Y, Z & C Dimensions)*.
- (2) Using dimension ‘C’ measured from the pulley shaft center, mark an arc “C” on the chute wall.
- (3) Move mainframe center location point along the arc “C” until a suitable location point is found away from the obstruction. Take care to avoid going past the 3 or 6 O’ Clock position. (Refer to Figure 4.)

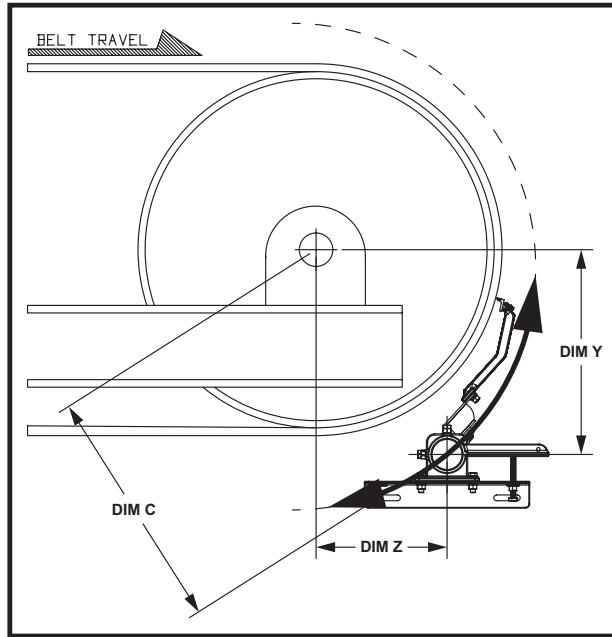
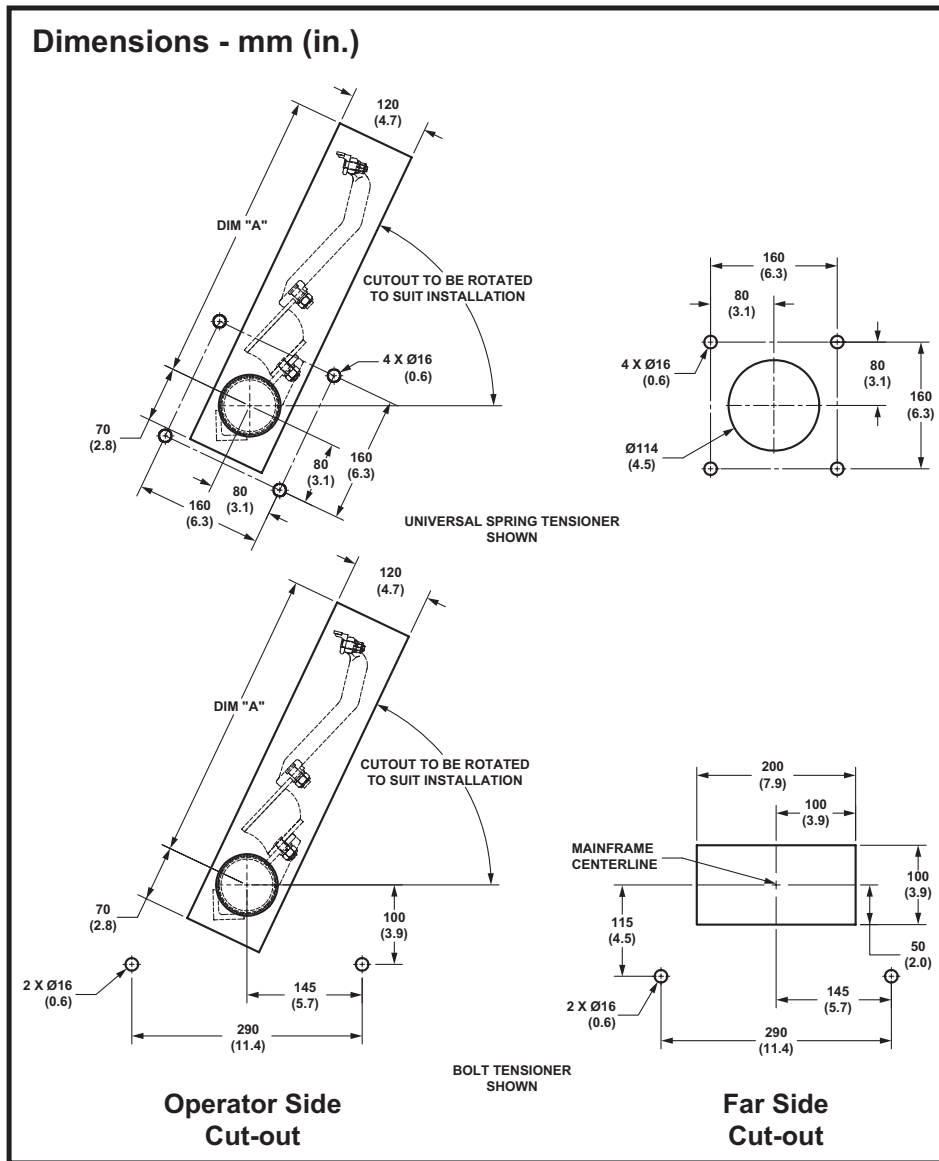

**Figure 4. Martin® H1 Primary Belt Cleaner HD Method 2  
Mainframe Coordinate Dimension**

**Table II. Martin® H1 Primary Belt Cleaner HD Coordinate Chart**

Arm Size	Pulley Dia + Lagging + Belt Thickness - mm (in.)	73mm Pole			
		Dim "X" - mm (in.)	Dim "Y" - mm (in.)	Dim "Z" - mm (in.)	Dim "C" - mm (in.)
SS	250 (9.8)	185 (7.3)	308 (12.1)	31 (1.2)	310 (12.2)
	300 (11.8)	170 (6.7)	315 (12.4)	55 (2.2)	320 (12.6)
	350 (13.8)	156 (6.1)	321 (12.6)	79 (3.1)	331 (13.0)
	400 (15.7)	144 (5.7)	328 (12.9)	103 (4.1)	344 (13.5)
	450 (17.7)	132 (5.2)	334 (13.1)	127 (5.0)	357 (14.1)
	500 (19.7)	123 (4.8)	341 (13.4)	151 (5.9)	373 (14.7)
S	500 (19.7)	167 (6.6)	396 (15.6)	129 (5.1)	417 (16.4)
	600 (23.6)	146 (5.7)	409 (16.1)	177 (7.0)	446 (17.5)
	700 (27.6)	127 (5.0)	421 (16.6)	225 (8.9)	477 (18.8)
	800 (31.5)	113 (4.4)	434 (17.1)	273 (10.7)	513 (20.2)
M	700 (27.6)	162 (6.4)	467 (18.4)	210 (8.3)	512 (20.2)
	800 (31.5)	145 (5.7)	480 (18.9)	258 (10.2)	545 (21.5)
	900 (35.4)	130 (5.1)	493 (19.4)	306 (12.0)	580 (22.8)
	1000 (39.4)	118 (4.6)	506 (19.9)	355 (14.0)	618 (24.3)
L	1000 (39.4)	124 (4.9)	529 (20.8)	350 (13.8)	624 (24.5)
	1100 (43.3)	111 (4.4)	542 (21.3)	378 (14.9)	661 (26.0)
	1200 (47.2)	100 (3.9)	555 (21.9)	427 (16.8)	700 (27.6)
LL	1200 (47.2)	189 (7.4)	669 (26.3)	418 (16.5)	789 (31.1)
	1300 (51.2)	176 (6.9)	682 (26.9)	466 (18.3)	826 (32.5)
	1400 (55.1)	164 (6.5)	695 (27.4)	514 (20.2)	864 (34.0)
	1500 (59.1)	154 (6.1)	708 (27.9)	562 (22.1)	904 (35.6)
	1600 (63.0)	145 (5.7)	721 (28.4)	611 (24.1)	945 (37.2)
	1700 (66.9)	136 (5.4)	734 (28.9)	659 (25.9)	986 (38.8)

9. Ensure fastener threads and belt are protected from weld splatter. Weld or bolt the mounting bracket into position on operator side, repeat for the opposite side. To allow for Mainframe installation, the operator's side pivot must be removed.
10. If installing into a chute, access and maintenance cut-outs will be required. (Refer to Figure 5 & Table III.)



**Figure 5. Martin® H1 Primary Belt Cleaner HD Chute Cutout Details**

**Table III. Martin® H1 Primary Belt Cleaner HD Operator Side Chute Cutout Details**

<b>Arm Size</b>	<b>Operator Side Dim "A" - mm (in.)</b>
SS	320 (12.6)
S	370 (14.6)
M	450 (17.7)
L	480 (18.9)
LL	580 (22.8)

**Mainframe installation**

- Slide the mainframe into position or through the chute, if present, allowing the tips to hang down. (Refer to Figure 6.) Install pivots onto mounts but do not tighten.

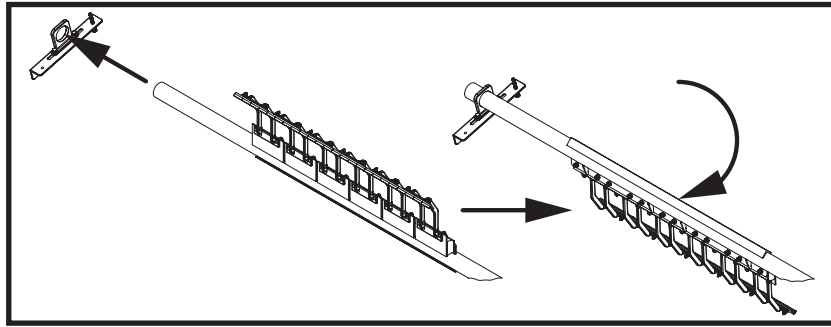

**Figure 6. Martin® H1 Primary Belt Cleaner HD Mainframe Installation**

- Install the adjuster arms onto mounts but do not tighten. (Refer to Figure 7.)

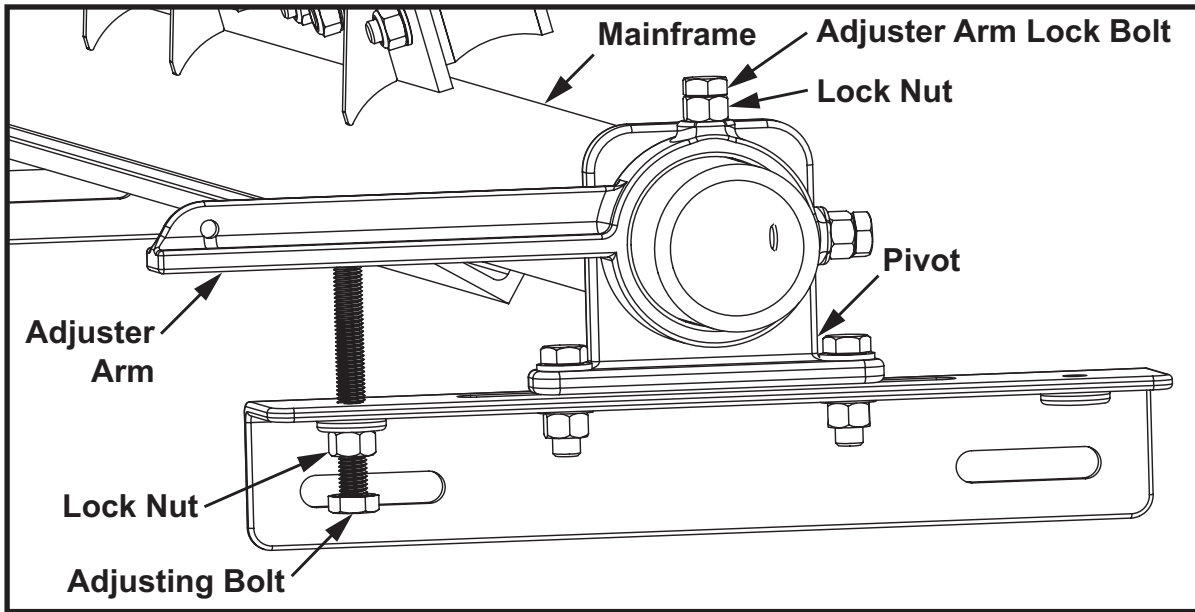

**Figure 7. Martin® H1 Primary Belt Cleaner HD Adjuster Arm**

- Rotate mainframe upward until tips make contact with the belt. Center tips across belt and tighten adjuster arms to retain mainframe in center position. Ensure adjuster arms are resting on adjusting bolt. (Refer to Figure 8.)
- Adjust pivot mounts until cleaner tips on both sides contact the belt. This is to ensure the cleaner is properly aligned with the belt. (Refer to 8.)

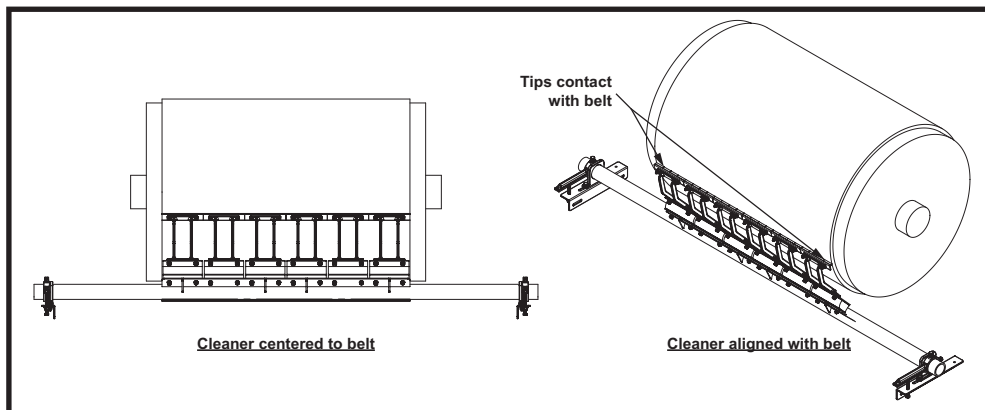

**Figure 8. Martin® H1 Primary Belt Cleaner HD Tip Contact**

## Tip tension and adjustment

### NOTE

Martin® H1 Primary Belt Cleaner HD are factory set with tips aligned straight.

### NOTE

Cleaner tips will not make even contact across the width of the belt on crowned pulleys or worn belt profiles. Buffer shimming is required to adjust the tips to the belt profile to obtain full performance and efficiency. Excess carryback will be evident if not done correctly.

### ⚠ WARNING

Tips must be aligned with the belt. Poor performance will result if maintenance or service crews do not perform this task with each service.

### NOTE

All shimming is to be done between the buffer and the mainframe. (Refer to Figure 9.)

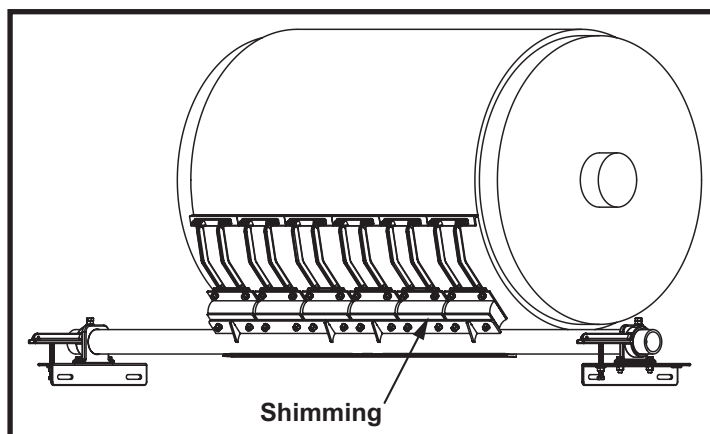

**Figure 9. Martin® H1 Primary Belt Cleaner HD Shimming**

15. Loosen both the buffer retaining nuts on the buffer to be shimmed. Press the tip against the belt and add required shims to obtain full contact with the tip and belt profile. Tighten buffer retaining nuts and repeat for each buffer until even contact is made across the width of the belt. (Refer to Figure 10.)

### ⚠ WARNING

Ensure there is 0.5 mm (0.02 in.) to 1 mm (0.04 in.) clearance between each tip to prevent chipping.

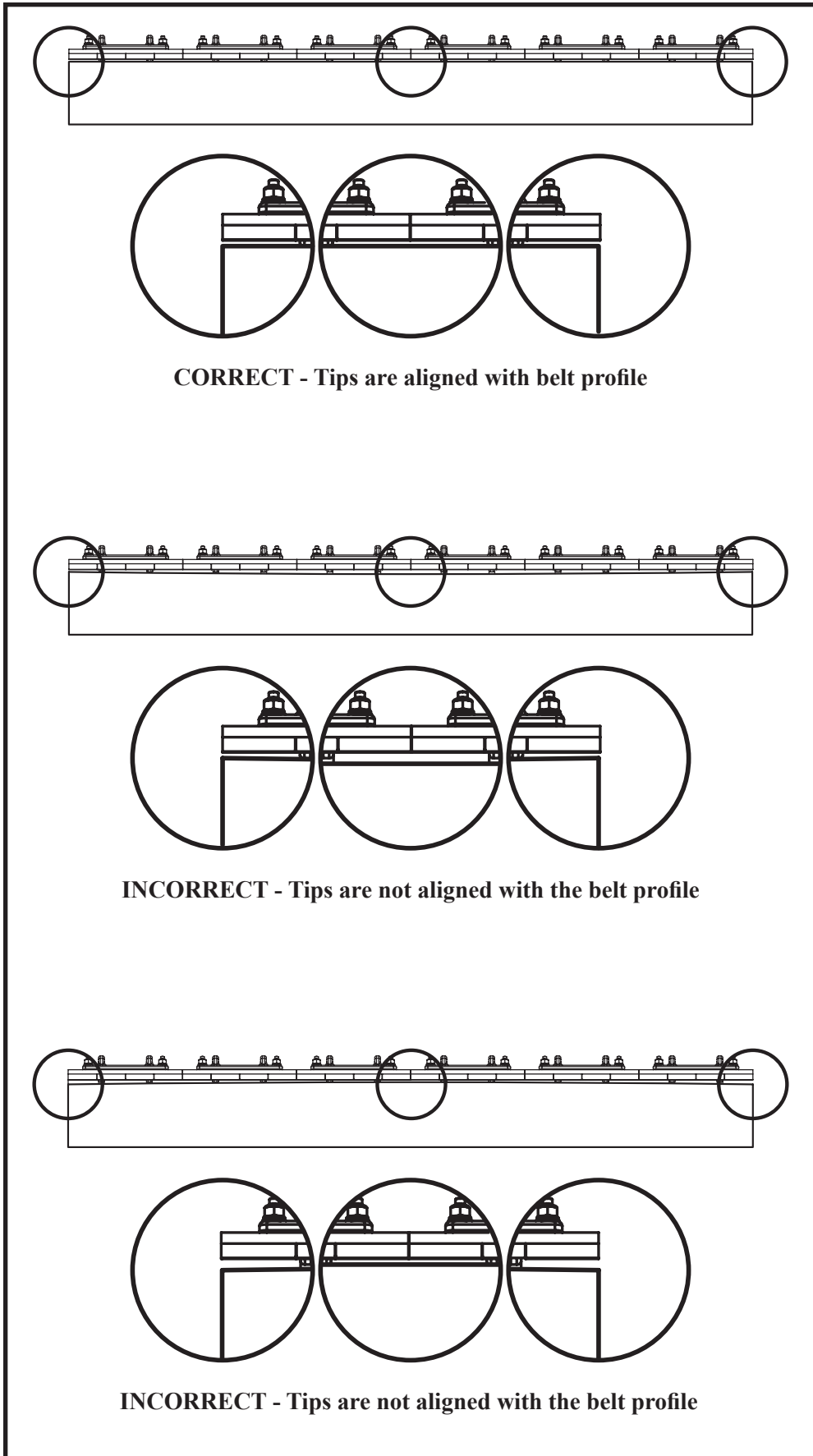
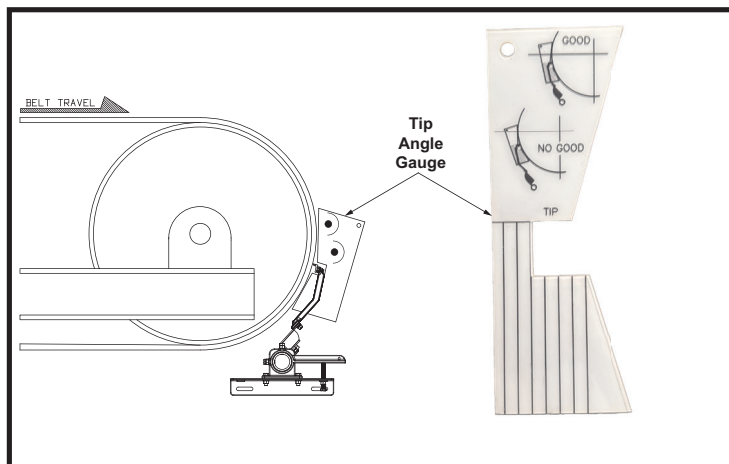

Figure 10. Martin® H1 Primary Belt Cleaner HD Tip Alignment

16. A tip angle gauge is provided with the cleaner and is used to verify the tip attack angle. Align the angled edges located on the right side of the gauge over the belt cleaner ensuring contact is made with the belt. Align the second edge marked “Tip” with top of the H Tip. (Refer to Figure 11.) The back of the arm should not cover the first three lines starting from the left of the gauge and be parallel to the vertical lines marked on the gauge.



**Figure 11. Martin® H1 Primary Belt Cleaner HD Tip Angle Gauge**

17. With the tips adjusted and aligned to the belt profile, ensure all tip and buffer fasteners are all tightened. Tips should follow belt profile and have 0.5 mm (0.02 in.) to 1 mm (0.04 in.) clearance between tips to prevent chipping of the tungsten.

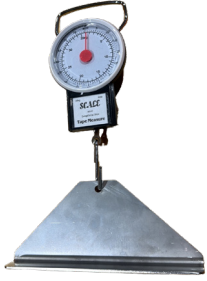

**▲ WARNING**

**USE A SPRING SCALE TO TENSION THE CLEANER TO A VALUE BETWEEN 7 KGS (15.4 LBS) AND 8 KGS (17.6 LBS) PER TIP FOR STANDARD 3MM TIPS.**

**FOR HD 5MM TIPS, TENSION THE CLEANER TO A VALUE BETWEEN 9 KGS (19.8 LBS) AND 11 KGS (24.3 LBS).**

**VALUE STATED MUST BE FORCE NECESSARY TO PULL THE TIP OFF THE BELT.**

**EXCESS TENSION MAY LEAD TO POOR PERFORMANCE AND BELT WEAR.**



18. While the tips are touching the belt, adjust tension on the adjuster arms by adjusting the adjusting bolt. When the tension is set, tighten the lock nut. (Refer to Figure 12.)

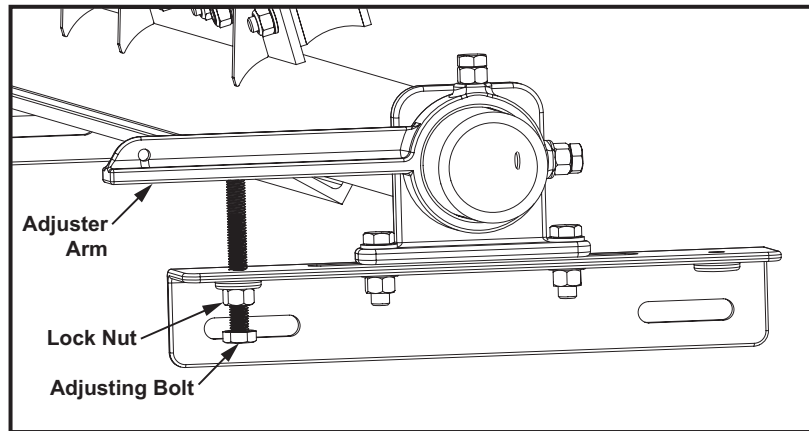
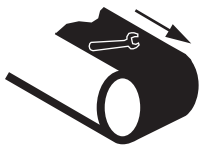

**Figure 12. Martin® H1 Primary Belt Cleaner HD Tensioner Adjustment Hardware**

# After Installing Belt Cleaner



1. Thoroughly wipe chute wall clean above tensioner.
2. Place Conveyor Products Warning Label (P/N 23395) on outside chute wall visible to belt cleaner operator.
3. Additional safety labels are available from CEMA. For more information regarding CEMA safety labels visit [www.cemanet.org](http://www.cemanet.org).
4. Recheck that all fasteners are tightened properly.
5. Check the product contact area on the belt.



**⚠ WARNING**

**Failure to remove tools and material from installation area and conveyor belt before turning on energy source can cause serious injury to personnel and damage to belt.**



**⚠ DANGER**

**Do not touch or go near conveyor belt or conveyor accessories when conveyor belt is running. Body or clothing can get caught and pull body into conveyor belt, causing severe injury or death.**

6. Turn on conveyor belt for 1 hour, then turn off.



**⚠ DANGER**

**Before adjusting the belt cleaner or tensioner, turn off and lockout / tagout / blockout / testout all energy sources to the conveyor and conveyor accessories according to ANSI standards. Failure to do so could result in serious injury or death.**

- a. Make sure all fasteners are tight. Tighten if necessary.
- b. Make sure cleaner is not changing belt line. If it is, install belt support ahead of tip-to-belt contact point (Secondary Cleaner).
- c. Inspect belt cleaner for the following:
  - Wear. (A small amount of “break-in” wear may be found. This will stop once tips wear to conveyor belt contour.)
  - Material buildup. (No material between tips and return side of conveyor belt should be found.)
- d. If wear, material buildup, or some other problem exists, see “Troubleshooting.”

## Maintenance

---

### IMPORTANT

Read entire section before beginning work.

### Visual inspection

#### NOTE

**Visual inspection should be performed no less than once every 4 weeks. Some applications may require more frequent visual inspections.**

1. Visually inspect the belt and cleaner.
  - If cleaner is set for optimal tensioning.
  - If belt looks clean or if there are areas that are dirty.
  - If tips are worn out and need to be replaced.
  - If buffers have delamination between rubber and plates.
  - If there is damage to the tips or other cleaner components.
  - If fugitive material is built up on the cleaner or in the transfer area.
  - If there is cover damage to the belt.
  - If there is vibration or bouncing of the cleaner on the belt.
  - If a snub pulley is used, a check should be made for material build up on the pulley.
  - Significant signs of carryback.
  - Check water sprays if a spray cleaner is utilized.
2. If any of the above conditions exist, a decision should be made on when to stop the conveyor for cleaning maintenance.

### Physical inspection

#### NOTE

**Physical inspection should be performed no less than once every 3 months. Some applications may require more frequent physical inspections.**



#### ⚠ DANGER

**Before inspecting the belt cleaner, tensioner, or belt turn off and lockout / tagout / blockout / testout all energy sources to the conveyor and conveyor accessories according to ANSI standards. Failure to do so could result in serious injury or death.**

3. When the conveyor is not operating and properly locked out, a physical inspection of the product's performance should be undertaken.
  - Clean material build up off of the cleaner blade and mainframe.
  - Closely inspect the tips for wear and any damage and replace if needed.
  - Ensure full tip to belt contact.
  - Inspect the cleaner mainframe for damage.
  - Inspect all fasteners for tightness and wear. Tighten or replace as needed.
  - Replace any worn or damaged components.
  - Check the tension of the cleaner tips to the belt. Adjust the tension if necessary.
  - Check and clean Water Sprays if a Spray Cleaner is utilized.
  - When maintenance tasks are completed, test run the conveyor to ensure the cleaner is performing properly.

4. If any of the above conditions exist, a decision should be made on when to stop the conveyor for cleaning maintenance.



**⚠ DANGER**

**Before servicing the belt cleaner, tensioner, or related components turn off and lockout / tagout / blockout / testout all energy sources to the conveyor and conveyor accessories according to ANSI standards. Failure to do so could result in serious injury or death.**

***Arm / buffer / tip  
service instructions***

5. To inspect arms, buffers, and tips, follow the steps:
  - a. Release all tension on the cleaner tips.
  - b. Loosen adjuster arms and allow the cleaner tips to lay downwards.
  - c. Remove mainframe assembly.
  - d. Place mainframe in safe area to allow tip and buffer service or for inspection.
  - e. Remove all arms, buffers, and tips and inspect for damage.
  - f. Check mainframe for straightness and wear.
  - g. Check all components for wear and replace as required.
6. When replacing tips and buffers, ensure both flat and spring washers are utilized with the nyloc nuts to prevent possibility of tips coming loose. (Refer to Figure 13.)

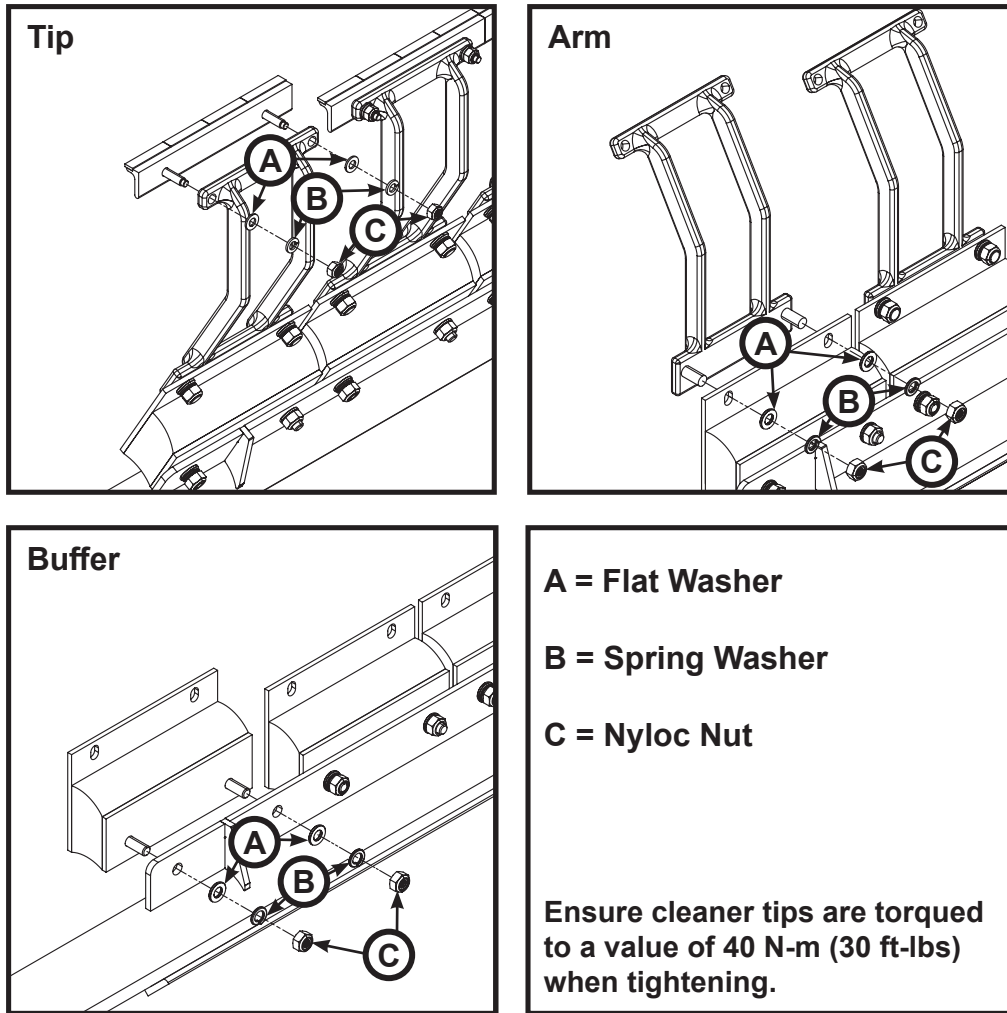

**Figure 13. Martin® H1 Primary Belt Cleaner HD Arm, Buffer, Tip Installation**

7. Repeat steps found in (See “Tip Tension and Adjustment”) for tip and buffer set up to ensure tips are correctly aligned and adjusted to the belt profile.

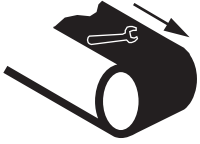

**⚠ WARNING**

**Failure to remove tools and material from maintenance area and conveyor belt before turning on energy source can cause serious injury to personnel and damage to belt.**

8. Remove all tools from maintenance area.

**⚠ DANGER**

**Do not touch or go near conveyor belt or conveyor accessories when conveyor belt is running. Body or clothing can get caught and pull body into conveyor belt, causing severe injury or death.**

9. Start conveyor belt. Observe belt cleaner operation for several revolutions of the belt. Service or adjust belt cleaner as necessary to ensure proper belt cleaner operation.

# Troubleshooting



**⚠ DANGER**

Before installing, servicing, or adjusting the belt cleaner or tensioner, turn off and lockout / tagout / blockout / testout all energy sources to the conveyor and conveyor accessories according to ANSI standards. Failure to do so could result in serious injury or death.

Symptom	Possible Cause	Possible Solution
Vibration	Cleaner pivots or mounting bolts not set	Ensure all locking nuts are tight
	Cleaner not set up correctly	Ensure cleaner set up properly (check tip attack angle with gauge)
	Belt tension too high	Ensure cleaner can conform to belt, or consider an alternate secondary cleaner
	Belt deformed on pulley	Replace pulley lagging
	Cleaner over tensioned	Ensure cleaner is correctly tensioned
	Cleaner under-tensioned	Ensure cleaner is correctly tensioned
Material build up on cleaner	Cleaner not set up correctly	Ensure cleaner set up properly (check tip angle with gauge)
	Build up in chute	Ensure cleaner is not located too close to back of chute, allowing build up
	Cleaner being overburdened	Install secondary cleaners
	Excessive sticky material	Frequently clean unit of build-up. Introduce Spray Bar and Water Control Manifold
Damaged belt cover	Cleaner over-tensioned	Check cleaner is correctly tensioned
	Cleaner tip damaged	Check blades / tips for wear, damage and chips, replace where necessary
	Attack angle not correct	Ensure cleaner set up properly (check tip attack angle with gauge)
	Material build up in chute	Frequently clean unit of build up
Cleaner not conforming to belt	Cleaner not set up correctly	Ensure cleaner set up properly (check tip attack angle with gauge)
	Belt tension too high	Ensure cleaner can conform to belt, or replace with alternate secondary cleaner
	Belt flap	Replace pulley lagging
	Cleaner cannot conform	Set up buffers and tips as detailed in "Tip Tension and Adjustment"
	Wear profile in belt cover	Set up buffers and tips as detailed in "Tip Tension and Adjustment"
Material passing cleaner	Cleaner not set up correctly	Ensure cleaner set up properly (check tip attack angle with gauge)
	Cleaner tension too low	Ensure cleaner is correctly tensioned
	Cleaner blades / tips worn or damaged	Check blades / tips for wear, damage and chips, replace where necessary
	Cleaner being overburdened	Install primary or additional secondary cleaner
	Belt deformed on pulley	Replace pulley lagging
	Belt worn or grooved	Install Spray Bar and Water Control Manifold
	Cleaner cannot conform	Ensure cleaner can conform to belt, or add secondary cleaner
Wear profile in belt cover	Set up buffers and tips as detailed in "Tip Tension and Adjustment"	
Damage to mechanical fastener	Incorrect cleaner tip selection	Change tip type to accommodate fastener style
	Belt not skived correctly	Spot and redo fastener correctly, lowering the profile flush or below belt surface
	Tip attack angle incorrect	Reset with gauge
Missing material in belt center only	Capped Belt	Set up buffers and tips as detailed in "Tip Tension and Adjustment"
	Cleaner tips worn/damaged	Check tips for wear, damage and chips, replace where necessary
Missing material on outer edges only	Capped Belt	Set up buffers and tips as detailed in "Tip Tension and Adjustment"
	Cleaner tips worn or damaged	Check tips for wear, damage and chips, replace where necessary

**NOTE**

Conveyor equipment such as conveyor belt cleaners are subject to a wide variety of bulk materials characteristics and often have to perform under extreme operating or environmental conditions. It is not possible to predict all circumstances that may require troubleshooting. Contact Martin Engineering or a representative if you are experiencing problems other than those listed in the "Troubleshooting" chart above. Do not return the equipment to operation until the problem has been identified and corrected.

# Part Numbers

This section provides product names and corresponding part numbers for Martin® H1 Primary Belt Cleaner HD and related equipment. Please reference part numbers when ordering parts:

## Martin® H1 Primary Belt Cleaner

**Martin® H1 Primary Belt Cleaner HD:**  
P/N C1HXXXSXXXXXXXXX. See Figure 14.

<b>NOMENCLATURE</b>	<b>C1H</b>	<b>X</b>	<b>X</b>	<b>X</b>	<b>SXX</b>	<b>XX</b>	<b>X</b>	<b>X</b>	<b>X</b>	<b>X</b>
P/N Prefix	_____	_____	_____	_____	_____	_____	_____	_____	_____	_____
Mainframe Duty	_____	_____	_____	_____	_____	_____	_____	_____	_____	_____
Mainframe Type	_____	_____	_____	_____	_____	_____	_____	_____	_____	_____
Arm Type	_____	_____	_____	_____	_____	_____	_____	_____	_____	_____
Belt Width (inches)	_____	_____	_____	_____	_____	_____	_____	_____	_____	_____
Number Of Tips	_____	_____	_____	_____	_____	_____	_____	_____	_____	_____
Tip Type	_____	_____	_____	_____	_____	_____	_____	_____	_____	_____
Buffer	_____	_____	_____	_____	_____	_____	_____	_____	_____	_____
Mainframe Material	_____	_____	_____	_____	_____	_____	_____	_____	_____	_____
Tensioner	_____	_____	_____	_____	_____	_____	_____	_____	_____	_____

<b>MAINFRAME DUTY</b>	<b>TIP TYPE</b>
H : Heavy Duty (73mm)	1 : 10X3
	2 : 15X5
<b>MAINFRAME TYPE</b>	<b>BUFFER</b>
1 : 1-Piece	5 : 55A SS
	7 : 70A SS
<b>ARM TYPE</b>	<b>MAINFRAME MATERIAL</b>
1 : SS	P : Painted Steel
2 : S	E : Extended Painted Steel *
3 : M	F : 304 SS
4 : L	Z : 304 SS Extended *
5 : LL	
<b>BELT WIDTH</b>	<b>TENSIONER</b>
SXX : SXX indicates belt width in inches (18 thru 102)	B : Bolt
	C : Compression Spring
<b>NUMBER OF TIPS</b>	S : Spring
XX : XX indicates number of tips	N : None

\* Extended mainframe is 305 mm (12 in.) longer than standard mainframes.

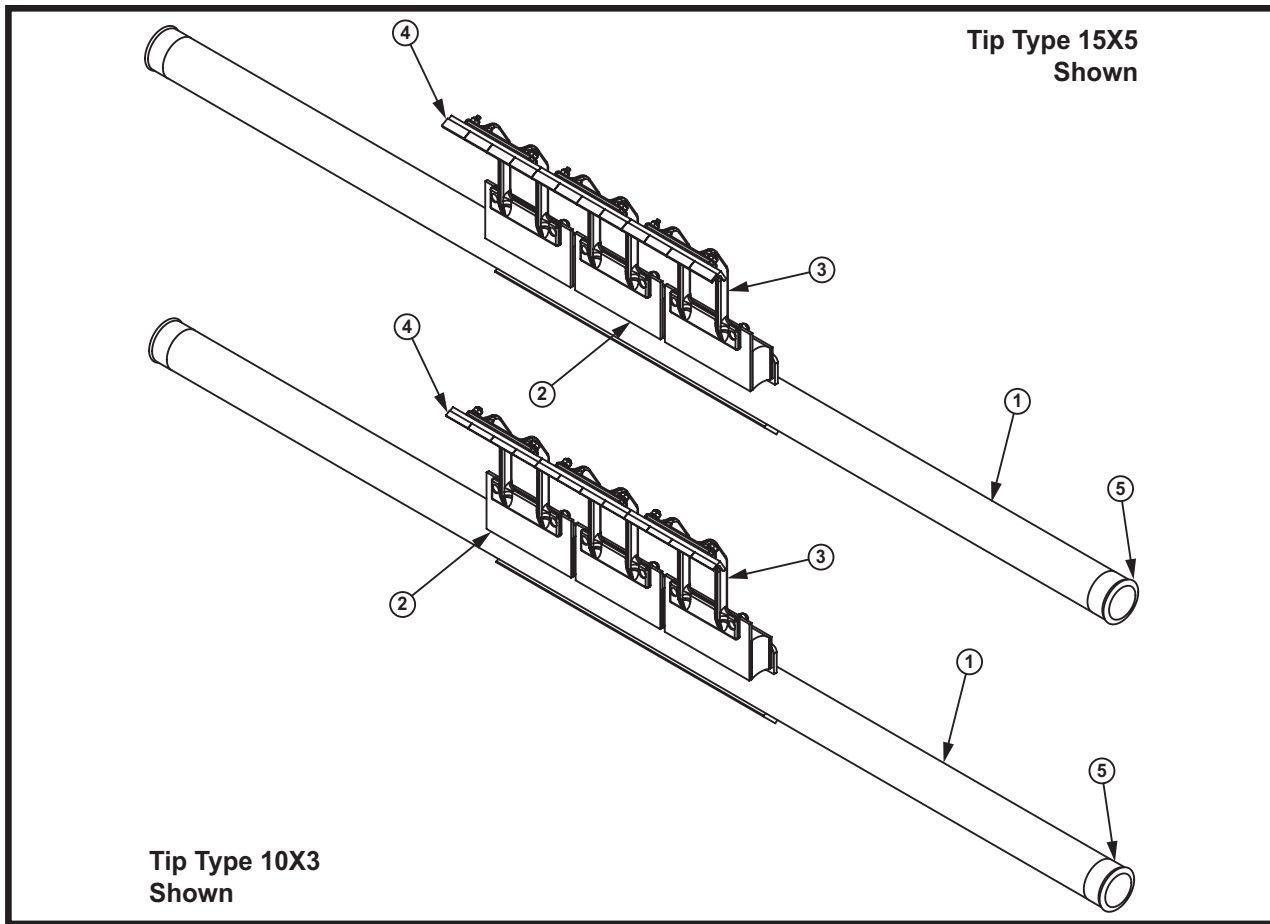

**Figure 14. Martin® H1 Primary Belt Cleaner HD, P/N C1HXXSXXXXXXXX**

Item	Description	Part No.	Qty
1	Mainframe Assembly	Table IV	1
2	Buffer Assembly	Table V	Table IV
3	Arm Assembly	Table VI	Table IV
4	Tip Assembly	Table VII	Table IV
5	Vinyl Cap W/Flange 2 3/4 ID X .070 Wall X 1 1/2 Deep	SUS10142	2
(NS) 6	Label Martin Product	38048	2
(NS) 7	Label Conveyor Product Warning	23395	2
(NS) 8	Tensioner Assembly	Table VIII	1
(NS) 9	Operator's Manual	M4226	1

NS = Not Shown

**Table IV-A. Martin® H1 Primary Belt Cleaner HD Mainframe Part Numbers and Quantities.**

Part Number	P/N Item 1	QTY 2, 3, 4
C1HH1XS1801XXXX	C1HH1MS1801X	1
C1HH1XS1802XXXX	C1HH1MS1802X	2
C1HH1XS2402XXXX	C1HH1MS2402X	2
C1HH1XS2403XXXX	C1HH1MS2403X	3
C1HH1XS3003XXXX	C1HH1MS3003X	3
C1HH1XS3004XXXX	C1HH1MS3004X	4
C1HH1XS3603XXXX	C1HH1MS3603X	3
C1HH1XS3604XXXX	C1HH1MS3604X	4
C1HH1XS4204XXXX	C1HH1MS4204X	4
C1HH1XS4205XXXX	C1HH1MS4205X	5
C1HH1XS4805XXXX	C1HH1MS4805X	5
C1HH1XS4806XXXX	C1HH1MS4806X	6
C1HH1XS5405XXXX	C1HH1MS5405X	5
C1HH1XS5406XXXX	C1HH1MS5406X	6
C1HH1XS6006XXXX	C1HH1MS6006X	6
C1HH12X6007XXXX	C1HH1MS6007X	7
C1HH12X6607XXXX	C1HH1MS6607X	7
C1HH1XS6608XXXX	C1HH1MS6608X	8
C1HH1XS7208XXXX	C1HH1MS7208X	8
C1HH1XS7209XXXX	C1HH1MS7209X	9
C1HH1XS7808XXXX	C1HH1MS7808X	8
C1HH1XS7809XXXX	C1HH1MS7808X	9
C1HH1XS8409XXXX	C1HH1MS8409X	9
C1HH1XS8410XXXX	C1HH1MS8410X	10
C1HH1XS9010XXXX	C1HH1MS9010X	10
C1HH1XS9011XXXX	C1HH1MS9011X	11
C1HH1XS9611XXXX	C1HH1MS9611X	11
C1HH1XS9612XXXX	C1HH1MS9612X	12
C1HH1XSA212XXXX	C1HH1MSA212X	12
C1HH1XSA213XXXX	C1HH1MSA213X	13

**Table IV-B. Martin® H1 Primary Belt Cleaner HD Extended Mainframe Part Numbers\*.**

Part Number	P/N Item 1
C1HH1XS1801XXEX	C1HH1MS1801X
C1HH1XS1802XXEX	C1HH1MS1802X
C1HH1XS2402XXEX	C1HH1MS2402X
C1HH1XS2403XXEX	C1HH1MS2403X
C1HH1XS3003XXEX	C1HH1MS3003X
C1HH1XS3004XXEX	C1HH1MS3004X
C1HH1XS3603XXEX	C1HH1MS3603X
C1HH1XS3604XXEX	C1HH1MS3604X
C1HH1XS4204XXEX	C1HH1MS4204X
C1HH1XS4205XXEX	C1HH1MS4205X
C1HH1XS4805XXEX	C1HH1MS4805X
C1HH1XS4806XXEX	C1HH1MS4806X
C1HH1XS5405XXEX	C1HH1MS5405X
C1HH1XS5406XXEX	C1HH1MS5406X
C1HH1XS6006XXEX	C1HH1MS6006X
C1HH1XS6007XXEX	C1HH1MS6007X
C1HH1XS6607XXEX	C1HH1MS6607X
C1HH1XS6608XXEX	C1HH1MS6608X
C1HH1XS7208XXEX	C1HH1MS7208X
C1HH1XS7209XXEX	C1HH1MS7209X
C1HH1XS7808XXEX	C1HH1MS7808X
C1HH1XS7809XXEX	C1HH1MS7809X
C1HH1XS8409XXEX	C1HH1MS8409X
C1HH1XS8410XXEX	C1HH1MS8410X
C1HH1XS9010XXEX	C1HH1MS9010X
C1HH1XS9011XXEX	C1HH1MS9011X
C1HH1XS9611XXEX	C1HH1MS9611X
C1HH1XS9612XXEX	C1HH1MS9612X
C1HH1XSA212XXEX	C1HH1MSA212X
C1HH1XSA213XXEX	C1HH1MSA213X

\*Use P/N C1HH1XSXXXXXXXXZX for 304 SS Extended

**Table V. Martin® H1 Primary Belt Cleaner HD Buffer Part Numbers.**

Part Number	P/N Item 2
C1HH1XSXXXXX5XX	B14-C10-001
C1HH1XSXXXXX7XX	B14-C10-002

**Table VI. Martin® H1 Primary Belt Cleaner HD Arm Part Numbers**

Part Number	P/N Item 3
C1HH1X1SXXXXXXXXXX	B13-C10-023
C1HH1X2SXXXXXXXXXX	B13-C10-024
C1HH1X3SXXXXXXXXXX	B13-C10-025
C1HH1X4SXXXXXXXXXX	B13-C10-026
C1HH1X5SXXXXXXXXXX	B13-C10-027

**Table VII. Martin® H1 Primary Belt Cleaner HD Tip Part Numbers**

Part Number	P/N Item 4
C1HH1XSXXXXX1XXX	B13-C10-005
C1HH1XSXXXXX2XXX	B13-C10-006

**Table VIII. Martin® H1 Primary Belt Cleaner HD Tensioner Part Numbers**

Part Number	P/N Item 8
C1HH1XSXXXXXXXXXB	B13-A10-006
C1HH1XSXXXXXXXXXC	B34-10-001
C1HH1XSXXXXXXXXXS	Table IX

**Table IX. Martin® Spring Tensioner Part Numbers**

Part Number	P/N Item 8 Spring Tensioner	P/N Item 8 SS Spring Tensioner
18 THRU 42	38003	38003-C
48 AND ABOVE	38003-2	38003-2-C

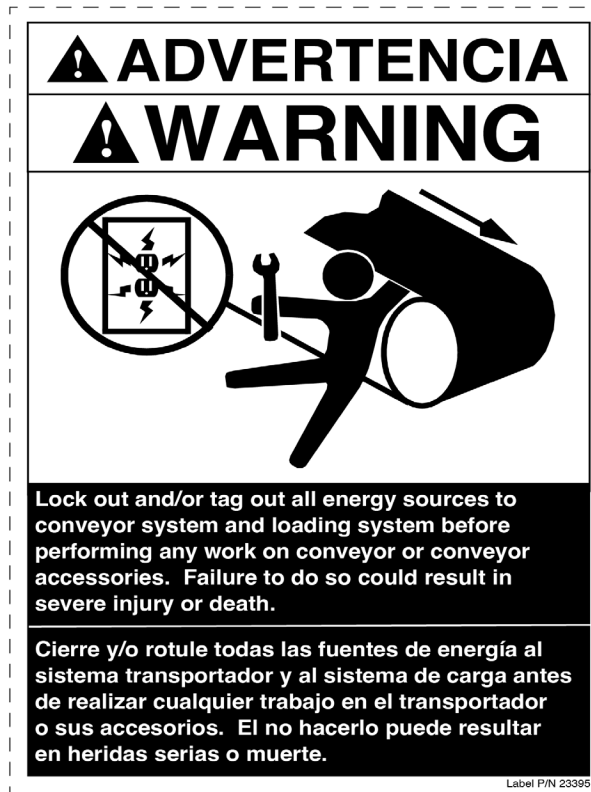
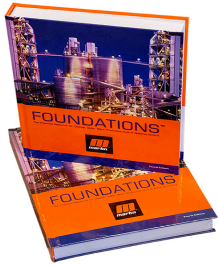

Figure 15. Conveyor Products Warning Label, P/N 23395

*Any product, process, or technology described here may be the subject of intellectual property rights reserved by Martin Engineering Company. Trademarks or service marks designated with the ® symbol are registered with the U.S. Patent and Trademark Office and may be proprietary in one or more countries or regions. Other trademarks and service marks belonging to Martin Engineering Company in the United States and/or other countries or regions may be designated with the “TM” and “SM” symbols. Brands, trademarks, and names of other parties, who may or may not be affiliated with, connected to, or endorsed by Martin Engineering Company, are identified wherever possible.*

*Additional information regarding Martin Engineering Company’s intellectual property can be obtained at [www.martin-eng.com/trademarks](http://www.martin-eng.com/trademarks).*

# **Problem Solved™** ***GUARANTEED!***



*For nearly 30 years, Martin Engineering's Foundations™ Books have taught industry personnel to operate and maintain clean and safe belt conveyors. The Foundations™ Book, fourth edition, focuses on improving belt conveyors by controlling fugitive material. "The Practical Resource for Total Dust and Material Control," is a 576-page hard cover volume that provides information of value to industries where the efficient handling of bulk materials is a key to productivity and profitability.*

*Expanding upon the book, our Foundations™ Training Program addresses the design and development of more productive belt conveyors, and is offered in three customizable seminars. Attendees gain a better understanding of conveyor safety and performance, helping to justify upgrade investments and increase profitability.*



## **Martin Engineering AUS**

102 Christensen Road South

Stapylton, QLD 4207 AUS

1300 627 364

[salesau@martin-eng.com](mailto:salesau@martin-eng.com)

[www.martin-eng.com.au](http://www.martin-eng.com.au)