

Martin® Passport Retrofit Valve

To upgrade performance and reduce maintenance, the [Martin® Passport Retrofit Valve](#) can be retrofit onto air cannon systems from any manufacturer. A simple, 8-bolt attachment allows the valve assembly to be installed on existing Martin Engineering air cannons.

BENEFITS

- Leading-Edge Valve Technology
- Increase Performance
- Ease of Maintenance
- Keep Existing Tank
- Upgrades All Air Cannon Models

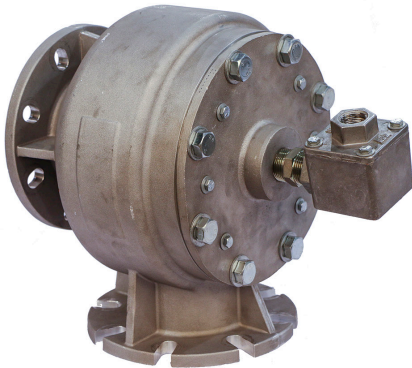

P/N 39558-FD
Negative Pressure Firing

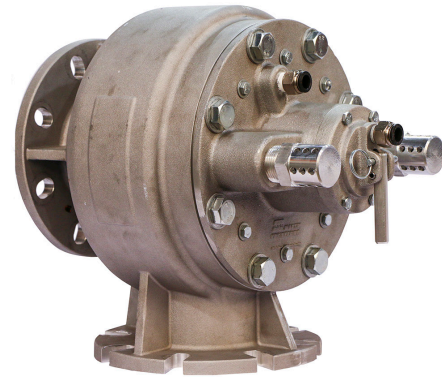

P/N 39558-H
Positive Pressure Firing

DIMENSIONS

Model	P/N	Dim. A in. (mm)	Dim. B in. (mm)	Dim. C in. (mm)	Dim. D in. (mm)	Dim. E* in. (mm)	Shipping Weight lb (kg)
Passport	39558-FDSA	13.71(348)	10.25 (260)	21.10 (536)	9.02 (229)	9.00 (229)	63 (28.4)
Passport	39558-HSA	13.71(348)	10.25 (260)	19.46 (494)	9.02 (229)	9.00 (229)	67 (30.4)

*Discharge pipe connects to a 4 inch ANSI flange or DIN100.

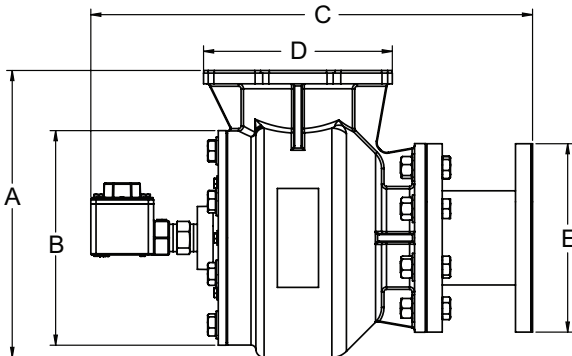

P/N 39558-FD SA
Negative Pressure Firing

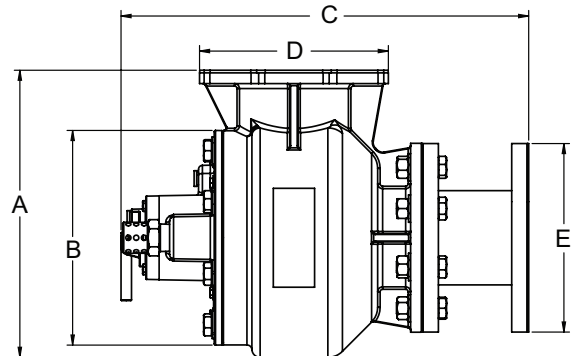

P/N 39558-H SA
Positive Pressure Firing



Martin Engineering RSA
Cnr Antwerpen Str. & Arnhemsingel, Die Heuwel,
Witbank, South Africa
+27 13 656 5135
Fax +27 13 656 5129
www.martin-eng.co.za

