

Martin® SQC2™ Cleaner

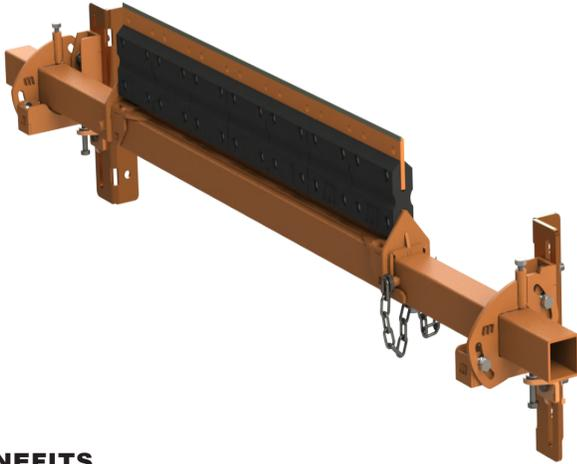

The **Martin® SQC2™ Cleaner** incorporates individually-cushioned tungsten carbide blades for effective cleaning without risk to belt, splice, or blade. Installed in the secondary cleaner position, the Martin® SQC2™ Cleaner's blade buffers cushion impact and maintains cleaning pressure.

BENEFITS

- Cushioned Blades Maintain Efficiency**
 Rubber buffers maintain cleaning pressure while deflecting to allow splices to pass.
- Built for Tough Conditions**
 Rugged construction withstands punishing applications, like high-speed belts and high-tonnage loads.
- Easy Cartridge Removal**
 The procedure is simple: remove pin, slide out cartridge, service, and return.
- Fits in Tight Spaces**
 Compact design allows installation in close quarters; narrow profile resists material buildup.
- Blades to Match Application**
 Specify tungsten carbide tips for normal, acidic, or high-impact conditions. Blades conform to belt profile by adjusting individually to provide continuous contact across the belt.
- Handles Reversing Belts and Belt Rollback**
 Rubber buffers allow for reversal of belt direction without damage to belt.

NOMENCLATURE(Singel)

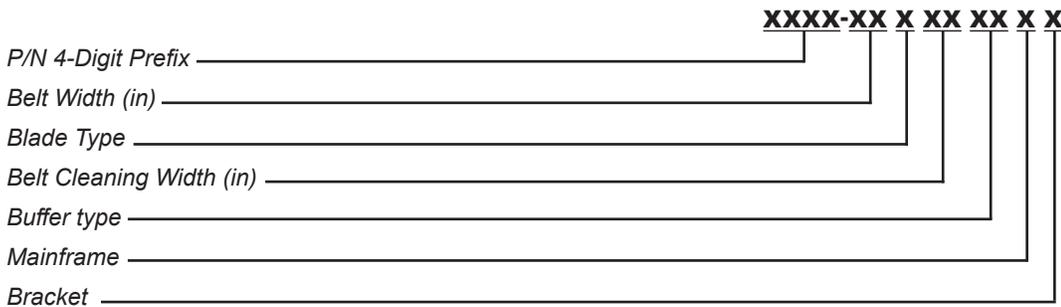

P/N 4-DIGIT PREFIX
SQC2: Standard Assembly

BELT WIDTH (INCHES)
 Full belt width

BLADE TYPE
C: Sandwich blade
D: High Abrasion Resistant blade
G: Acid Resistant Sandwich blade
H: Acid Resistant blade

BELT CLEANING WIDTH (INCHES)
 Full belt width

BUFFER TYPE
MR: Rubber buffer

MAINFRAME
P: Orange

BRACKET
T: SQC2 Bracket

TECHNICAL DATA SHEET

NOMENCLATURE(Double)

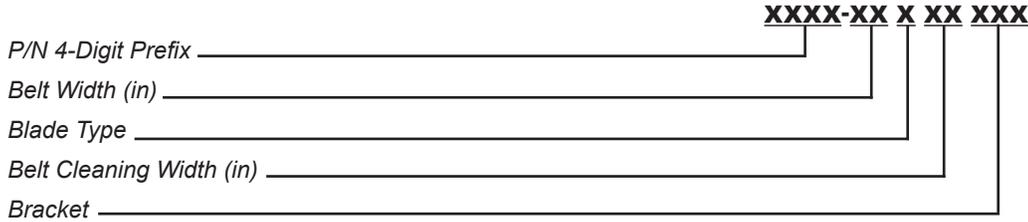

P/N 4-DIGIT PREFIX
SQC2: Standard Assembly

BELT CLEANING WIDTH (INCHES)
 Full belt width

BELT WIDTH (INCHES)
 Full belt width

BRACKET
DBL: Standard 450 Channel T-Bracket

BLADE TYPE
C: Sandwich blade
D: High Abrasion Resistant blade
G: Acid Resistant Sandwich blade
H: Acid Resistant blade

ACCESSORIES

SQC2 Mainframe	SQC2 Cartridge
SQC2-35694- XX -F	SQC2-CRD- XX
XX - Belt width (inches)	XX -Belt width (inches)

BLADE AND BUFFER TABLE ITEM 6 & 7		
BELT WIDTH MM (IN)	BLADES	BUFFERS
	QTY	QTY
600 (24)	4	4
750 (30)	5	5
900 (36)	6	6
1050 (42)	7	7
1200 (48)	8	8
1350 (54)	9	9
1500 (60)	10	10
1650 (60)	11	11
1800 (72)	12	12
1950 (78)	13	13
2100 (84)	14	14
2250 (90)	15	15
2400 (96)	16	16

TECHNICAL DATA SHEET

DIMENSIONS

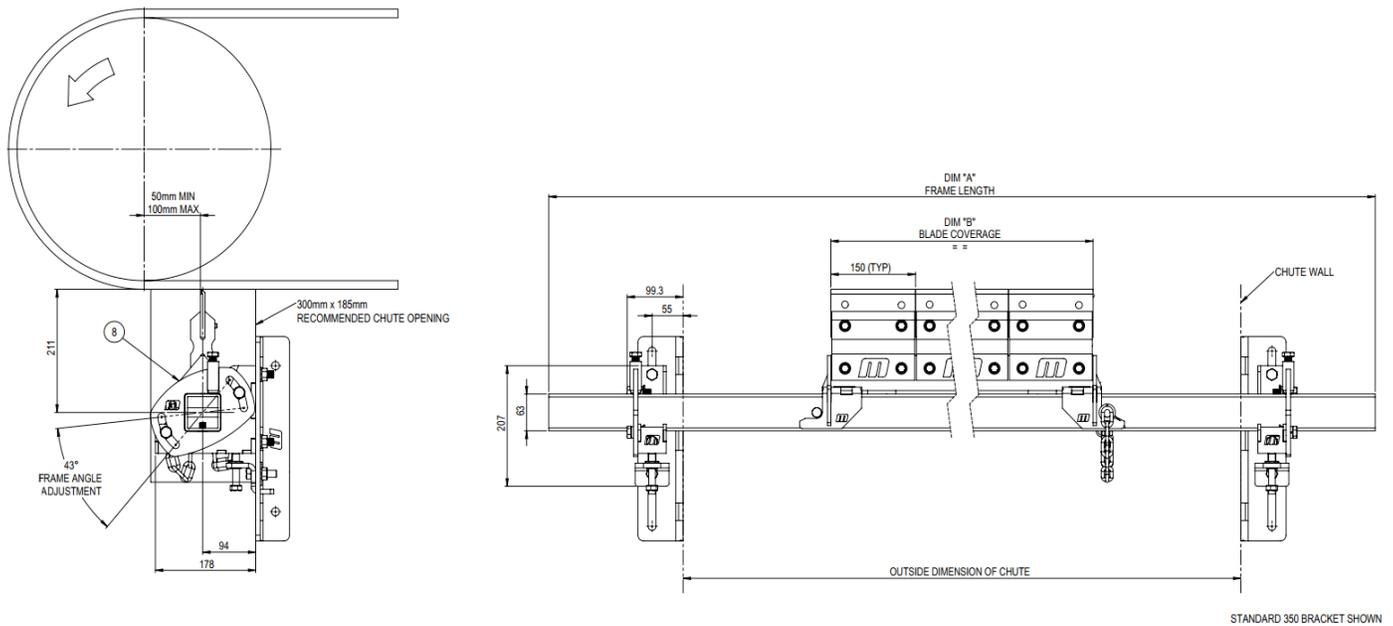

DIMENSIONAL TABLE			
PART NO.	BELT WIDTH MM (IN)	DIM "A" (MM)	DIM "B" (MM)
SQC2-24 X XX XX X X	600 (24)	1600	600
SQC2-30 X XX XX X X	750 (30)	1750	750
SQC2-36 X XX XX X X	900 (36)	1900	900
SQC2-42 X XX XX X X	1050 (42)	2050	1050
SQC2-48 X XX XX X X	1200 (48)	2400	1200
SQC2-54 X XX XX X X	1350 (54)	2550	1350
SQC2-60 X XX XX X X	1500 (60)	2700	1500
SQC2-66 X XX XX X X	1650 (66)	2950	1650
SQC2-72 X XX XX X X	1800 (72)	3000	1800
SQC2-78 X XX XX X X	1950 (78)	3150	1950
SQC2-84 X XX XX X X	2100 (84)	3300	2100
SQC2-90 X XX XX X X	2250 (90)	3450	2250
SQC2-96 X XX XX X X	2400 (96)	3600	2400



Martin Engineering RSA
 Cnr. Antwerpen Str. & Arnhemsingel, Die
 Heuwel, Witbank
 +27 13 656 5135
 Fax +27 13 656 5129
 www.martin-eng.co.za



Problem Solved™ GUARANTEED!

Form No. L3828-ZA
 © Martin Engineering Company 2019