



CleanScrape® Secondary Cleaner



Operating Instructions Part 2

Version: 0
Language: UK
M4128EUK-04/20

Table of Contents

1	General.....	2
1.1	About these operating instructions	2
1.2	Accompanying documents.....	2
1.3	Part number	3
1.4	Technical data	3
2	Installation	4
2.1	Removing tensioner.....	4
2.2	Installing cleaner.....	7
2.3	Tensioning cleaner	9
2.4	Attaching labels	11
3	Scope of delivery and spare parts	12
3.1	Secondary cleaner.....	12
3.2	Tensioner.....	14

1 General



NOTE

Before starting work on the cleaner or the conveyor, part 1 and 2 of these operating instructions must be read and understood completely

1.1 About these operating instructions

These operating instructions apply solely for cleaners and are intended for those persons who install cleaners, commission them, and monitor their usage.

The operating instructions must be kept for the lifetime of the cleaners and must be made available in an orderly condition to all persons entrusted with work with and on the cleaners.

1.2 Accompanying documents

Part 1 of the operating instructions, which is provided separately, is an integral part of these operating instructions.

1.3 Part number

Tensioner

SQC2S™ Square Mainframe Tensioners: P/N 38664-SS.

Cleaner

Part number

Product

Mainframe design

Belt width (inch)

Number of blades

Scraping edge material

Mainframe type

Tensioner

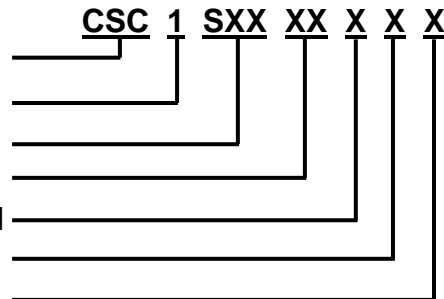

Scraping edge material

1: Tungsten carbide

Mainframe type

S: Stainless steel

Tensioner

(-): None

S: Stainless steel

1.4 Technical data

The cleaner is suitable for the following operating parameters:

	Operating parameter
Belt widths:	500 ... 2,600 mm
Pulley diameter:	any
Belt speed:	3 m/s for conveyor belts with mechanical splices
	5 m/s for conveyor belts with vulcanised splices
Temperature range:	-40 ... 315 °C
Reversing operation:	Yes

2 Installation

2.1 Removing tensioner

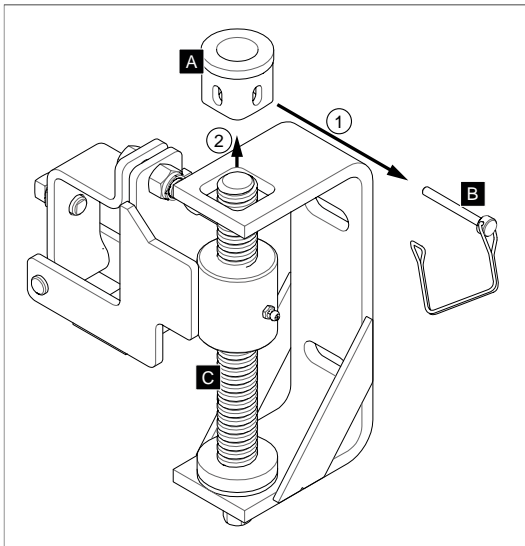

1. Pull out the Pin Wire Lock (B).
2. Remove the Top Bushing (A).

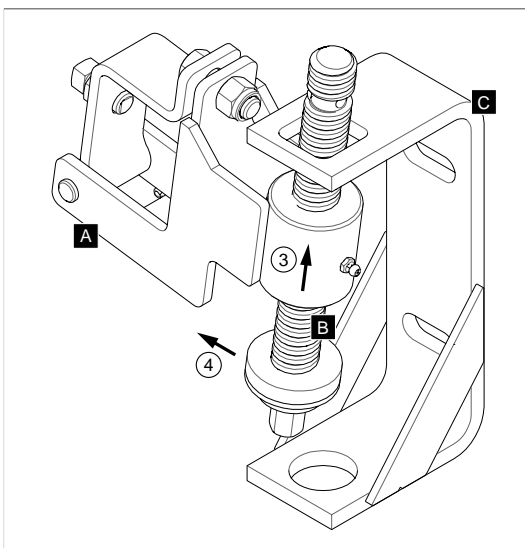

3. Slide the Pivot Block Insert (B) upwards.
4. Remove the Tensioner Arm Assembly (A) from the Mount Bracket Weldment (C).

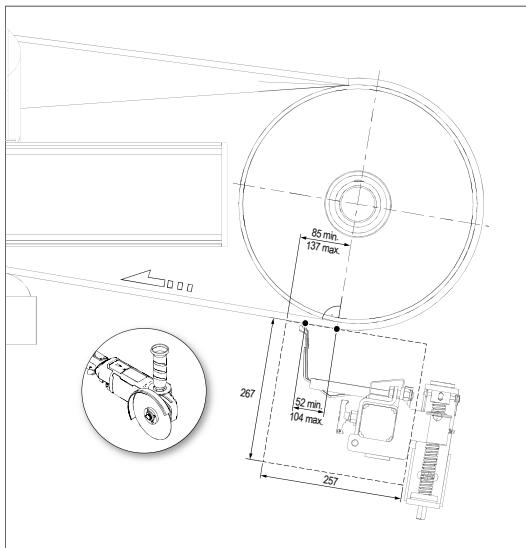

5. Determine the installation position of the cleaner and cut a corresponding opening out of the chute.



NOTE

In case of cylindrical pulleys, the distance to the tangent point can be reduced from 104-52 mm to 0 mm.

If the distance to the tangent point has been reduced to 0 mm, the blades lie directly on the tangent point.

- *Observe the position of the installation opening and adjust if necessary.*

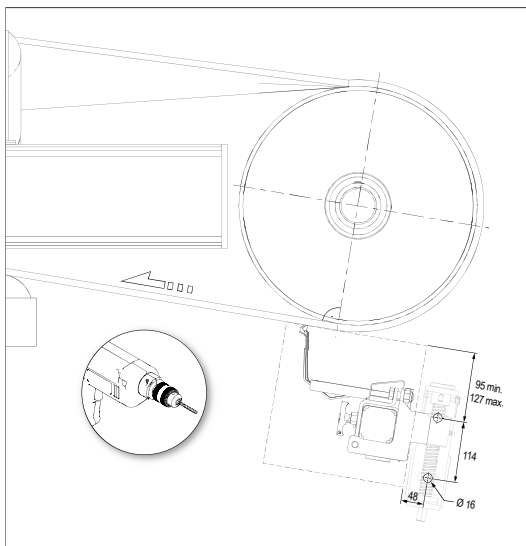

6. Determine the installation position of the tensioner and drill corresponding holes into the chute.

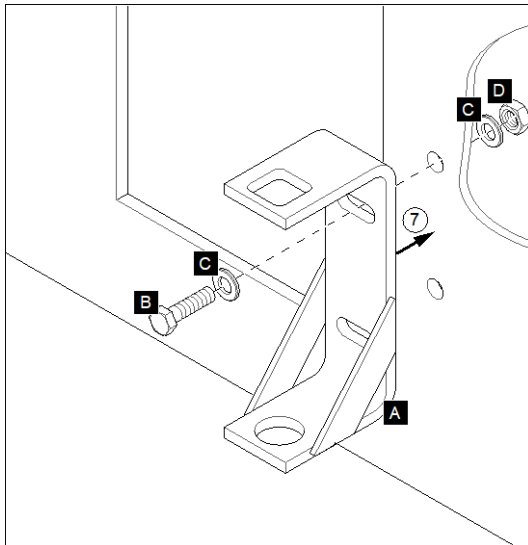

7. Attach the Mount Bracket Weldment (A) to the chute with screw (B), washers (C) and matching nut (D).

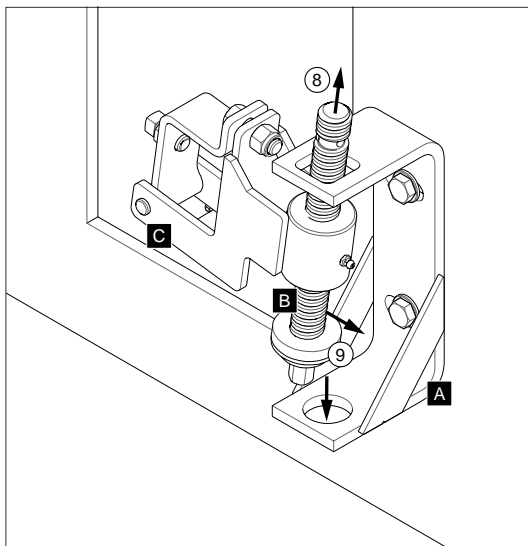

8. Insert the Tensioning Rod (B) into the upper opening of the Mount Bracket Weldment.
9. Insert the Tensioner Arm Assembly (C) in to the installation panel.

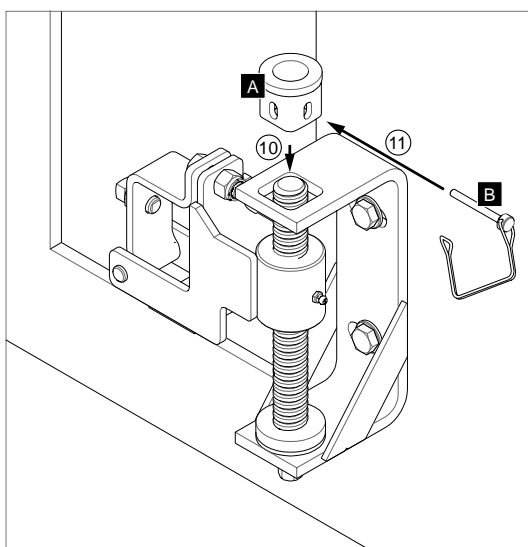

10. Insert the Top Bushing (A).
11. Insert the Pin Wire Lock (B).

2.2 Installing cleaner

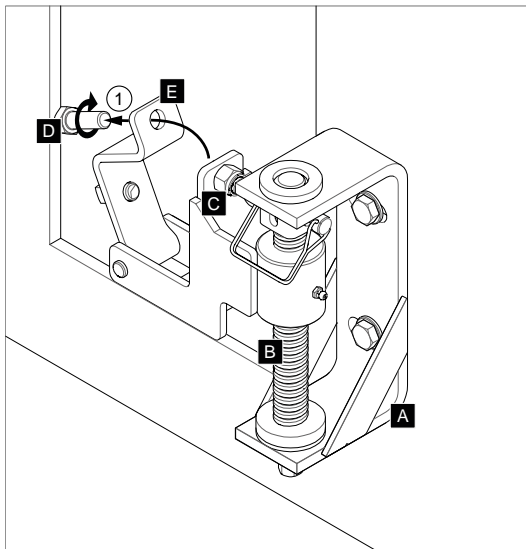

1. Unscrew the screw (D) on Hinge Clamp Weldment (E).

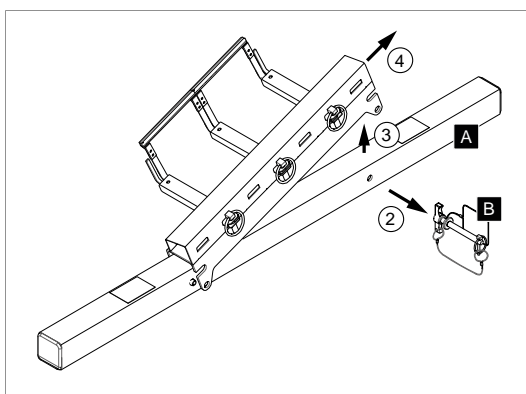

2. Remove the Pull Pin Assembly (B) from the cleaner.
3. Push the blade cartridge upwards.
4. Remove the blade cartridge.

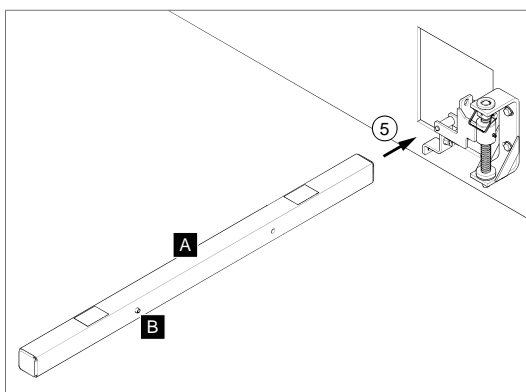

5. Insert the cleaner mainframe (A) into the Hinge Clamp Weldment so that the locking pin (B) points to the front.

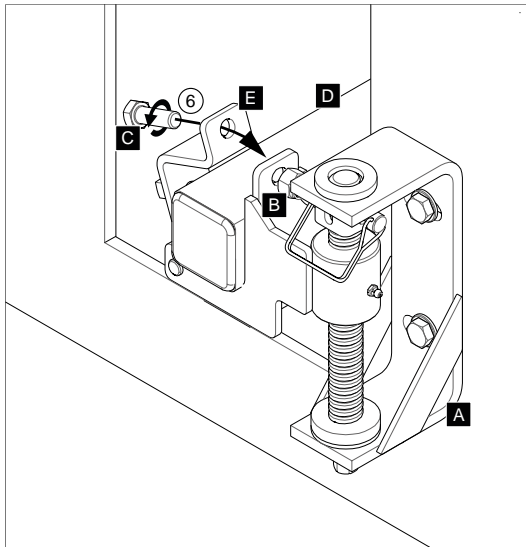

6. Tighten the Hinge Clamp Weldment (E) with the screw (C).

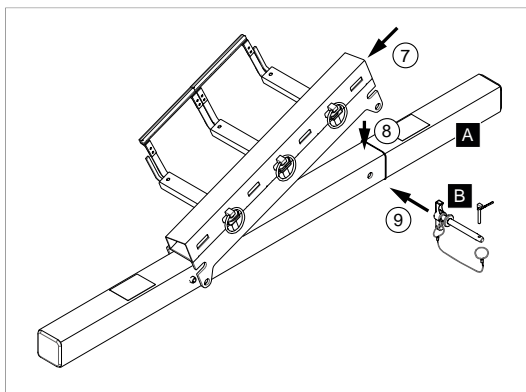

7. Insert the blade cartridge.
8. Place the blade cartridge on the locking pin of the cleaner mainframe (A).
9. Insert the Pull Pin Assembly (B).

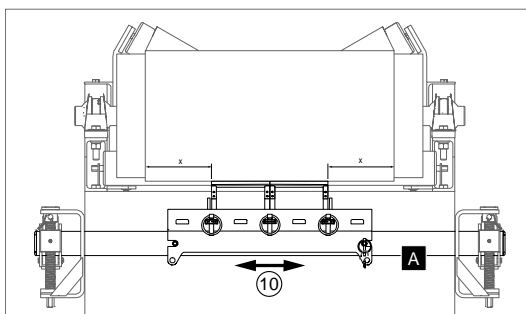

10. Align cleaner centrally.

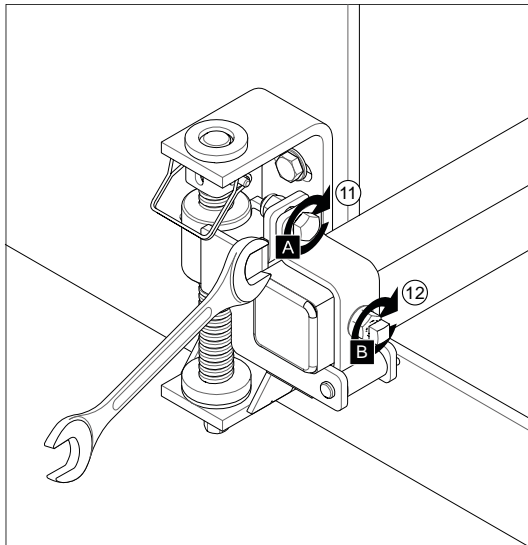

11. Tighten screw (A) firmly.
12. Tighten screw (B) firmly.

2.3 Tensioning cleaner

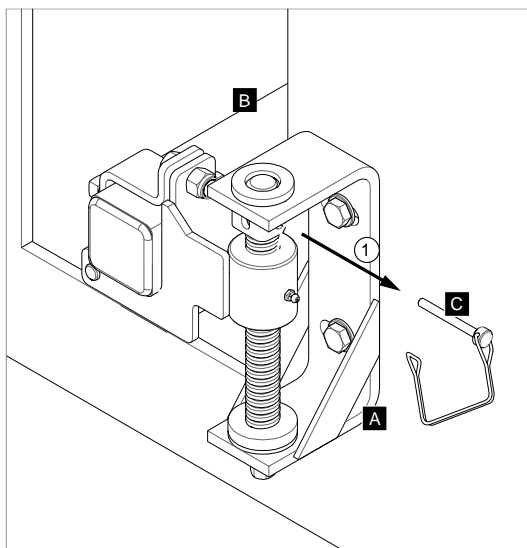

1. Remove Pin Wire Lock (C).

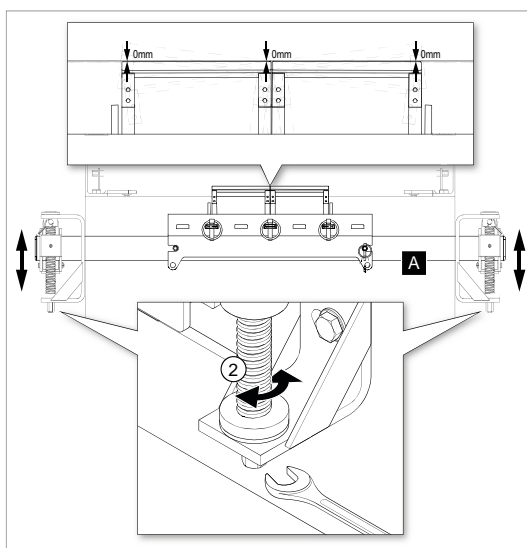

2. Turn the Tensioning Rods of the tensioners until all blades are slightly touching the belt.

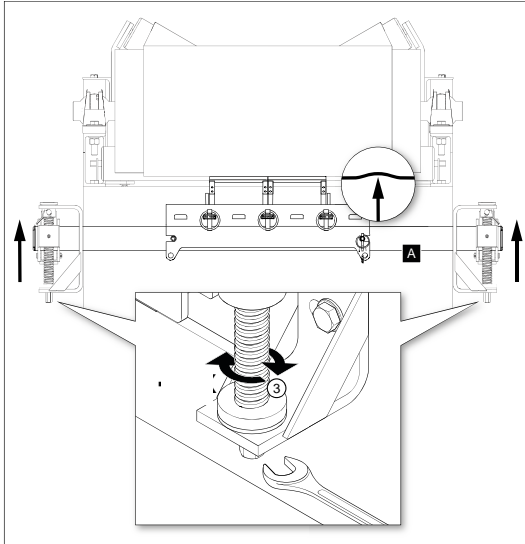

3. Turn one full turn to tighten the cleaner.

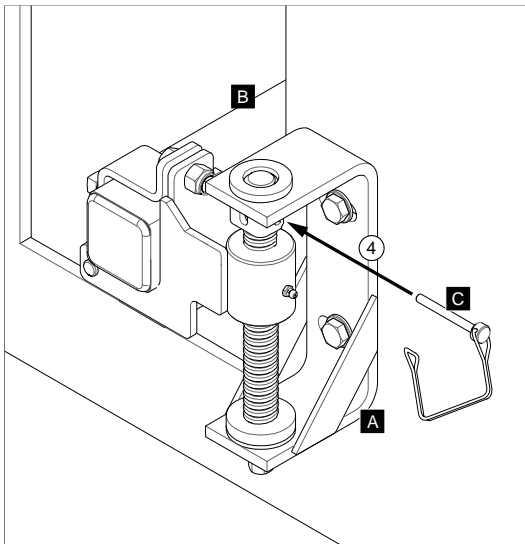

4. Insert Pull Pin Assembly (C).

2.4 Attaching labels

The following labels must be attached to the conveyor system in the immediate vicinity of the cleaner:

2.4.1 Warning Labels



2.4.2 Other labels

The following labels come already with the product or have to be placed in the immediate vicinity of the cleaner:

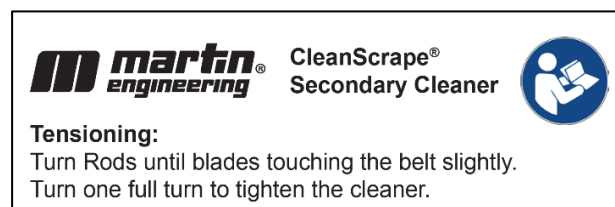

3 Scope of delivery and spare parts

3.1 Secondary cleaner

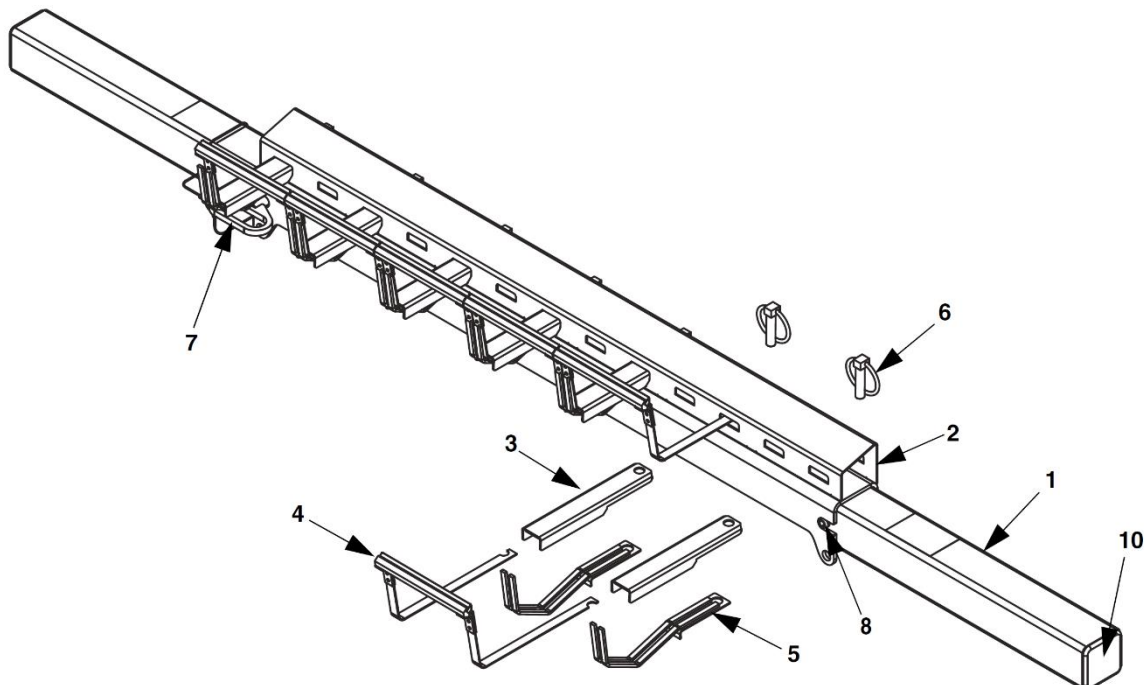

Item	Description	Part Number	Qty
1	Mainframe	Table I	1
2	Cartridge Weldment	Table I	1
3	Spring Arm Cover Weldment	C2CP1003S	Table I
4	Blade Arm Assembly	C2CB1	Table I
5	Spring Arm Weldment	C2CP1006S	Table I
6	Pin Locking Lynch 7/16	SUS10011S	Table I
7	Pull Pin Assembly	C2CP1019S	1
8	Pin Slotted Spring 1/2 x 3 SS	SUS10007S	1
9	Label Martin Product	38048	2
10	Plug	34896-02	2
11	Square Mainframe Tensioner Assembly (316 SS)	38664-SS	1
12	Manual Operator's	M4128	1

Remark: Labels and manuals parts numbers vary according to the region

Part No.	P/N Item 1	P/N Item 2	Qty Item 4	Qty Items 3, 5, 6
C2C1S1802XXXX	C2CPMS18S	C2CP1015S03S	2	3
C2C1S1803XXXX	C2CPMS18S	C2CP1015S03S	3	4
C2C1S2403XXXX	C2CPMS24S	C2CP1015S04S	3	4
C2C1S2404XXXX	C2CPMS24S	C2CP1015S04S	4	5
C2C1S3004XXXX	C2CPMS30S	C2CP1015S05S	4	5
C2C1S3005XXXX	C2CPMS30S	C2CP1015S05S	5	6
C2C1S3605XXXX	C2CPMS36S	C2CP1015S06S	5	6
C2C1S3606XXXX	C2CPMS36S	C2CP1015S06S	6	7
C2C1S4206XXXX	C2CPMS42S	C2CP1015S07S	6	7
C2C1S4207XXXX	C2CPMS42S	C2CP1015S07S	7	8
C2C1S4807XXXX	C2CPMS48S	C2CP1015S08S	7	8
C2C1S4808XXXX	C2CPMS48S	C2CP1015S08S	8	9
C2C1S5408XXXX	C2CPMS54S	C2CP1015S09S	8	9
C2C1S5409XXXX	C2CPMS54S	C2CP1015S09S	9	10
C2C1S6009XXXX	C2CPMS60S	C2CP1015S10S	9	10
C2C1S6010XXXX	C2CPMS60S	C2CP1015S10S	10	11
C2C1S6610XXXX	C2CPMS66S	C2CP1015S11S	10	11
C2C1S6611XXXX	C2CPMS66S	C2CP1015S11S	11	12
C2C1S7211XXXX	C2CPMS72S	C2CP1015S12S	11	12
C2C1S7212XXXX	C2CPMS72S	C2CP1015S12S	12	13
C2C1S7812XXXX	C2CPMS78S	C2CP1015S13S	12	13
C2C1S7813XXXX	C2CPMS78S	C2CP1015S13S	13	14
C2C1S8413XXXX	C2CPMS84S	C2CP1015S14S	13	14
C2C1S8414XXXX	C2CPMS84S	C2CP1015S14S	14	15
C2C1S9014XXXX	C2CPMS90S	C2CP1015S15S	14	15
C2C1S9015XXXX	C2CPMS90S	C2CP1015S15S	15	16
C2C1S9615XXXX	C2CPMS96S	C2CP1015S16S	15	16
C2C1S9616XXXX	C2CPMS96S	C2CP1015S16S	16	17

3.2 Tensioner

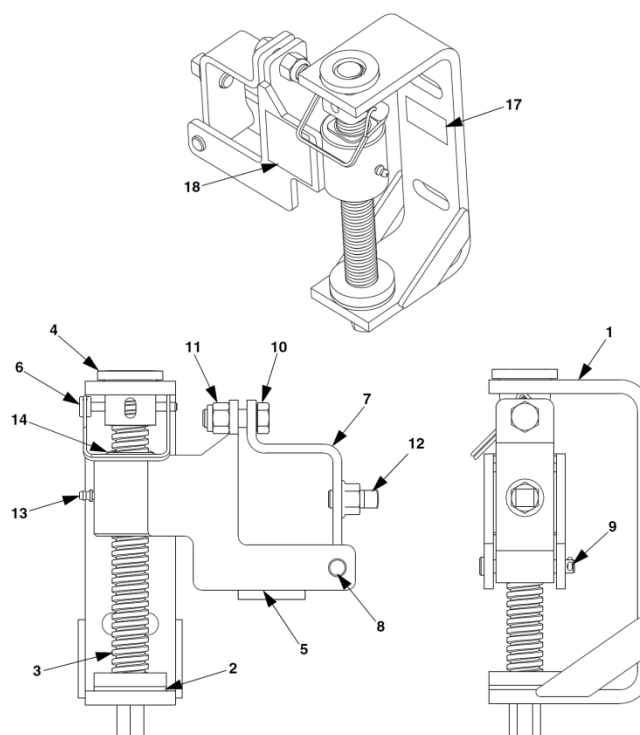

Item	Description	Part Number	Qty
1	Mount Bracket Weldment	35672	2
2	Bottom Bushing	35674	2
3	Tensioning Rod	35682	2
4	Top Bushing	35683-C	2
5	Tensioner Arm Assembly	38663	2
6	Pin Wire Lock 1/4 x 2.25 ZP	35685	2
7	Hinge Clamp Weldment	38661	2
8	Pin Clevis 3/8 x 2-1/2 ZP	35687	2
9	Pin Cotter 1/8 x 3/4 SS	31297	2
10	Screw HHC 1/2-13NC x 1-1/2 ZP	11763	2
11	Nut Hex Elastic Lock 1/2-13NC ZP	18577	2
12	Screw SHS 1/2-13NC x 1 SS	22763-03	2
13	Fitting Grease 3/16	38584	2
14	Pivot Block Insert	35684	2
15 (NS)	Mounting Hardware	35283	1
16 (NS)	Label Conveyor Products Warning	23395	2
17	Label Martin Products	32238	2
18	Label Tensioning	SQC2-10002	4
19 (NS)	Operator's Manual	M3815	1

Remark: Labels and manuals parts numbers vary according to the region

BLADE CHART
PART NUMBER P/N ITEM 4
C2C15360XXXX C20B1

PART NO.	DM "N"	DM "B"	DM "C"	DM "T"	P/N ITEM 1	P/N ITEM 2	QTY	ITEM	QTY	ITEM	QTY	WEIGHT	RD
							4	3	5	6			
C2C15360XXXX	15.74	15.74	15.74	15.74	C20B1	C20B1	2	1	2			0.27	
C2C15360XXXX	15.74	15.74	15.74	15.74	C20B1	C20B1	2	2	2			0.27	
C2C15360XXXX	15.74	15.74	15.74	15.74	C20B1	C20B1	2	3	2			0.27	
C2C15360XXXX	15.74	15.74	15.74	15.74	C20B1	C20B1	2	4	2			0.27	
C2C15360XXXX	15.74	15.74	15.74	15.74	C20B1	C20B1	2	5	2			0.27	
C2C15360XXXX	15.74	15.74	15.74	15.74	C20B1	C20B1	2	6	2			0.27	
C2C15360XXXX	15.74	15.74	15.74	15.74	C20B1	C20B1	2	7	2			0.27	
C2C15360XXXX	15.74	15.74	15.74	15.74	C20B1	C20B1	2	8	2			0.27	
C2C15360XXXX	15.74	15.74	15.74	15.74	C20B1	C20B1	2	9	2			0.27	
C2C15360XXXX	15.74	15.74	15.74	15.74	C20B1	C20B1	2	10	2			0.27	
C2C15360XXXX	15.74	15.74	15.74	15.74	C20B1	C20B1	2	11	2			0.27	
C2C15360XXXX	15.74	15.74	15.74	15.74	C20B1	C20B1	2	12	2			0.27	
C2C15360XXXX	15.74	15.74	15.74	15.74	C20B1	C20B1	2	13	2			0.27	
C2C15360XXXX	15.74	15.74	15.74	15.74	C20B1	C20B1	2	14	2			0.27	
C2C15360XXXX	15.74	15.74	15.74	15.74	C20B1	C20B1	2	15	2			0.27	
C2C15360XXXX	15.74	15.74	15.74	15.74	C20B1	C20B1	2	16	2			0.27	
C2C15360XXXX	15.74	15.74	15.74	15.74	C20B1	C20B1	2	17	2			0.27	

ITEM	QTY	DESCRIPTION	PART NUMBER
1	1	MANFRAME TUBE	SEE CHART
2	1	CARBIDE WELDMENT	SEE CHART
3	2	BLADE WELDMENT	SEE CHART
4	2	S/C CARTRIDGE	SEE BLADE CHART
5	2	S/C SPRING ARM WELDMENT	C2CPT10005
6	2	S/C SPRING ARM WELDMENT	SUS100115
7	1	PULL PIN ASM	C2CPT10195
8	1	PIN SLOTTED SPRING 1/2 X 3 S3	SUS100075
9	2	LABEL MARTIN PRODUCT	38048
10	2	PLUG FOR 2.50 OD TUBE	34886-02
11	1	WARRANT CARD	SEE WORKORDER ASM (116, 53)
12	1	MANUAL OPERATORS	M4128

NS - NOT SHOWN
S/C - SEE CHART

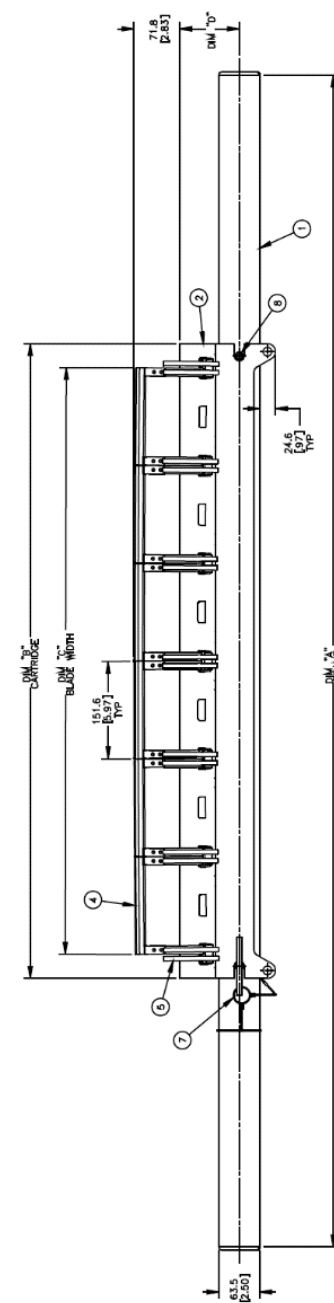
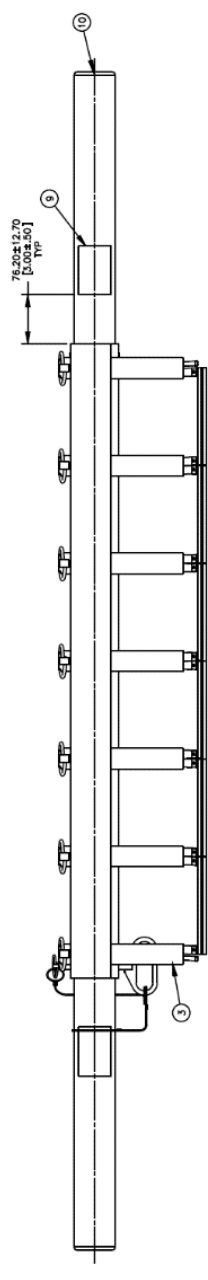
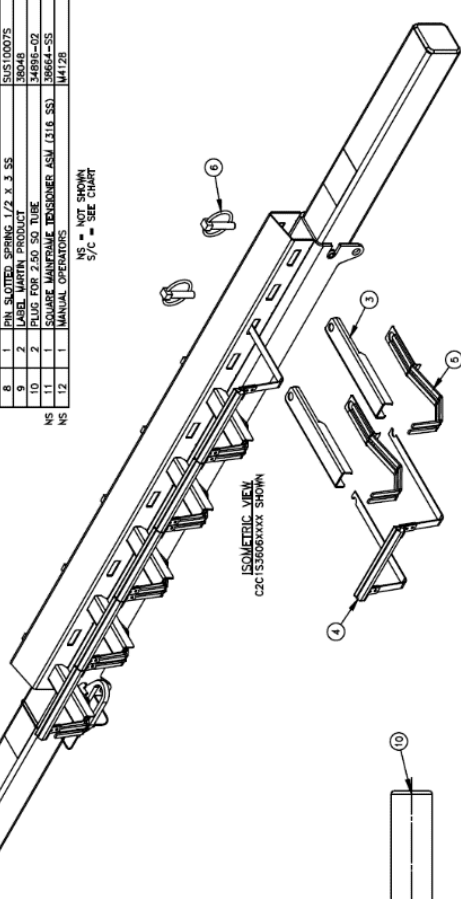

C2C15360XXXX SHOWN

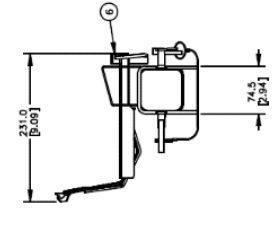
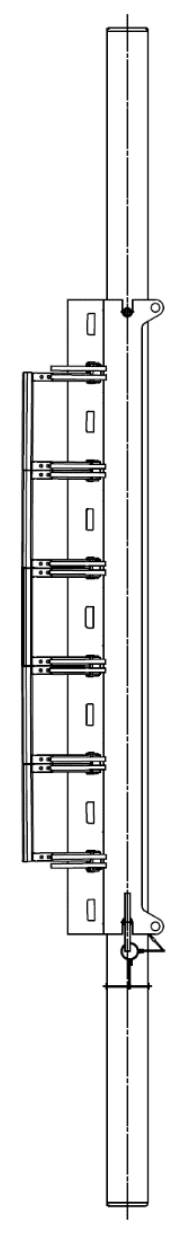

NOTES:
1) THE "C/C" PART NUMBER INDICATES CARTRIDGE TYPE MANFRAME, AND THE NEXT XX INDICATES THE NUMBER OF BLADES.
2) THE "S/C" PART NUMBER INDICATES SPRING ARM WELDMENT TYPE, AND THE NEXT X INDICATES THE MANFRAME TYPE.
3) THE "P/S" PART NUMBER INDICATES THE MANFRAME TYPE, AND THE NEXT X INDICATES THE TENSORER OPTIONS.
4) THE "L" PART NUMBER INDICATES THE TENSORER TYPE, AND THE NEXT X INDICATES THE TENSORER OPTIONS.
5 = STAINLESS STEEL

REV	DESCRIPTION	DATE	BY
1	ISSUE	06/09/19	JMH
2	REVISION	06/09/19	JMH
3	REVISION	06/07/19	JMH
4	REVISION	06/07/19	JMH
5	REVISION	06/07/19	JMH
6	REVISION	06/07/19	JMH
7	REVISION	06/07/19	JMH
8	REVISION	06/07/19	JMH
9	REVISION	06/07/19	JMH
10	REVISION	06/07/19	JMH
11	REVISION	06/07/19	JMH
12	REVISION	06/07/19	JMH

TITLE: CLEANSCRAPER SECONDARY CLEANER ASSEMBLY
 DRAWING NUMBER: C2C15360XXXXXX
 SCALE: 1:1
 CHECKED: JMH
 DATE: 06/09/19
 DRAWN: JMH
 DATE: 06/09/19
 APPROVED: JMH
 DATE: 06/09/19
 PART NUMBER: C2C15360XXXX

Germany

Martin Engineering GmbH
In der Rehbach 14, 65396 Walluf, Germany
Phone +49 (0)6123 0; Fax +49 (0)6123 75533
info@martin-eng.de; www.martin-eng.de

Spain

Martin Engineering Spain
c/Balmes 297 1er 2a, 08006 Barcelona, Spain
Phone +34 (0)876 245 114; Fax +34 (0)966 71 93 71
info@martin-eng.es; www.martin-eng.es

Great Britain

Martin Engineering Ltd.
8, Experian Way, NG2 Business Park,
Nottingham NG2 1EP, Nottinghamshire, Great Britain
Phone +44 (0)115 946 4746; Fax +44 (0)115 946 5550
info@martin-eng.co.uk; www.martin-eng.co.uk

Turkey

Martin Engineering Türkiye
Yukarı Dudullu İmes Sanayi Sitesi, B Blok 205 Sokak No.6
34775 Ümraniye Istanbul, Turkey
Phone +90 (0)216 499 34 91; Fax +90 (0)216 499 34 90
info@martin-eng.com.tr; www.martin-eng.com.tr

France

Martin Engineering SARL
50 Avenue d'Alsace, 68025 Colmar Cedex, France
Phone +33 (0)389 20 63204; Fax +33 (0)389 20 4379
info@martin-eng.fr; www.martin-eng.fr

Italy

Martin Engineering Italy Srl
Via Buonarroti, 43/A, 20064 Gorgonzola (MI), Italy
Phone +39 (0)295 383 851; Fax +39 (0)295 383 815
info@martin-eng.it; www.martin-eng.it

Russia

OOO Martin Engineering
Ul. Bolshaya Dmitrovka, 23/1
125009 Moscow, Russia
Phone 007 (0)495 181 33 43; Fax 007 (0)499 720 62 12
info@martin-eng.ru; www.martin-eng.ru