

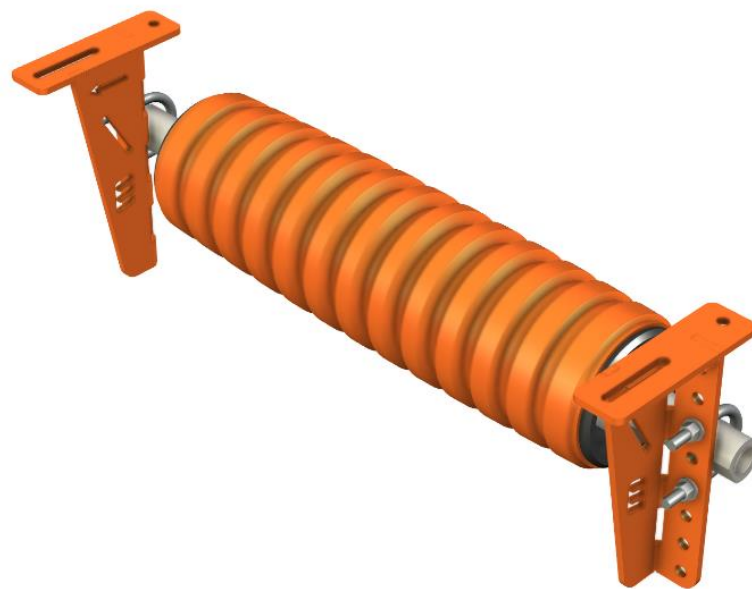

# Martin<sup>®</sup> Roller Tracker<sup>™</sup>



## Operating Instructions

Version: 0  
Language: ENG  
M4027E UK 2024-01 MRT

# Table of Contents

---

<b>1</b>	<b>General</b> .....	<b>2</b>
1.1	About these operating instructions.....	2
1.2	Intended usage.....	2
1.3	Personnel qualification .....	3
1.4	Part number .....	4
1.5	Technical Data .....	4
<b>2</b>	<b>Safety</b> .....	<b>5</b>
2.1	General safety instructions .....	5
2.2	Personal protective equipment .....	7
2.3	Safety markings on the system.....	7
<b>3</b>	<b>Before Installation</b> .....	<b>8</b>
3.1	Unpacking/transportation.....	8
3.2	Required maximum of tools and materials.....	8
<b>4</b>	<b>Installation</b> .....	<b>9</b>
4.1	Mounting the MRT .....	9
4.2	Placing labels .....	10
<b>5</b>	<b>Maintenance / Repair</b> .....	<b>11</b>
<b>6</b>	<b>Disassembly / Recycling / Disposal</b> .....	<b>12</b>
<b>7</b>	<b>Scope of delivery and spare parts</b> .....	<b>13</b>

# 1 General

---



## NOTE

Before starting work these operating instructions must be read and understood completely.

## 1.1 About these operating instructions

These operating instructions apply solely for Martin® Roller Tracker™ (MRT) and are intended for those persons who install MRTs, commission them, and monitor their usage.

The operating instructions must be kept for the lifetime of the MRT and must be made available in an orderly condition to all persons entrusted with work with and on the MRT.

## 1.2 Intended usage

The Martin® Roller Tracker™ are used on belt conveyors and serve to reduce the lateral deflection of conveyor belts. Depending on the design, they can be used on the lower belt.

They may only be used

- in industrial areas above ground
- at a sufficiently safe distance from danger points
- according to the technical data in the documentation
- in the installation position as described in the documentation

The usage of the Martin® Roller Tracker™ is only considered to be as intended if the following conditions are also fulfilled:

- Before starting initial work, the personnel must have been instructed on the work on the system and on all relevant issues of occupational health and safety.
- Any personal protective equipment required must be worn.
- The provisions of the operating instructions must be observed in full.

The Martin® Roller Tracker™ are not suitable to be used in potentially explosive areas of ATEX Zones as well as underground, as they are not designed for this purpose.

Operation of the MRT under deviating conditions and unauthorised modification of the MRT is considered as improper usage.

### 1.3 Personnel qualification

Only authorised and qualified personnel may be entrusted with work with and on the Martin® Roller Tracker™. Persons are considered qualified if they have the qualification of a skilled worker and meet all the following requirements:

- completed professional training or at least 5 years of professional experience in the field,
- technical experience,
- knowledge of the relevant occupational health and safety regulations.

The persons must

- be able to assess the tasks and risks assigned to them,
- be able to recognise potential dangers in advance,
- be physically and cognitively able to operate the conveyors and MRTs safely,
- have been trained and instructed appropriately,
- have read and understood these operating instructions.

Work on earth connections (Protective Bonding Kits), cabling, switching, control, regulation, automation, and all electrical components may be carried out only by trained electricians.

## 1.4 Part number



## 1.5 Technical Data

The Martin® Roller Tracker™ is suitable for the following operating parameters:

	Operating parameter
Belt widths:	400 – 1.600 mm
Belt speed:	Max. 5,0 m/s
Temperature range:	-30 – 60 °C
Reversing operation:	Yes

## 2 Safety

---

### 2.1 General safety instructions



#### DANGER

##### Entanglement in moving or rotating parts

Body parts and/or clothing may get caught and pulled in by moving or rotating parts of the machinery.

- *Before any installation or maintenance work is carried out, ensure that all power sources to the conveyor belt system and its accessories are switched off and secured against inadvertent switching on.*
- *Apply Log-Out / Tag-Out / Try-Out (LOTOTO) Procedures*
- *Apply warning signs*



#### DANGER

##### Automatic start-up of the conveyor

Serious or fatal injuries due to unintentional start-up of the conveyor.

- *Switch off the conveyor before starting work and secure it against being switched on again.*
- *Follow safe procedures to prevent unintentional restart.*



#### WARNING

##### Flying objects

Objects left on or in the conveyor can fly around uncontrollably when the conveyor is switched on and can hit and injure persons.

- *Before switching on the conveyor, remove all foreign objects such as tools, devices, etc. from the belt!*



## WARNING

### **Risk of falling down**

MRT are often mounted and operated in heights. There may be a risk of falling down.

- *Therefore, use a fall protection device when installing in higher working areas!*



## WARNING

### **Working in confined spaces**





Areas in which MRT are installed are often difficult to access and include confined spaces. It is often necessary to work in difficult positions.

- *Determine whether occupational safety measures are necessary that go beyond the usual measures!*

## 2.2 Personal protective equipment

Persons carrying out work on Martin® Roller Tracker™ must wear suitable personal protective equipment.

Minimum requirements:

Symbol	Meaning
	Wear head and eye protection
	Wear at least ankle-high foot protection
	Use gloves
	Use fall protection, if required

## 2.3 Safety markings on the system

The safety markings on the Martin® Roller Tracker™ must be kept in good condition and clearly visible at all times.

If parts of the system are replaced, ensure that the spare parts are or will be provided with appropriate safety markings.



## 3 Before Installation

---

### 3.1 Unpacking/transportation



#### WARNING

##### Heavy weight

The Martin® Roller Tracker™ may have weights that require handling by lifting devices. Handling MRT by hand can cause serious skeletal injuries.

- *Use suitable aids if the load is > 25 kg per person!*
- *Identify the centre of gravity! Ensure that the MRT cannot tilt during the lifting process!*

When unpacking, all components must be checked for completeness and intactness.

### 3.2 Required maximum of tools and materials

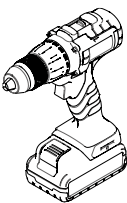
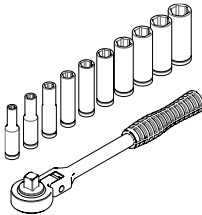
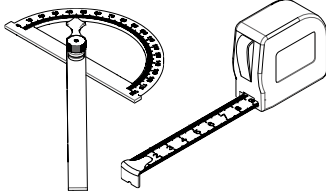
 <p>M12 Punch/13dia Drill</p>	 <p>2x 19mm Wrenches</p>	
--	---	---

## 4 Installation

### 4.1 Mounting the MRT

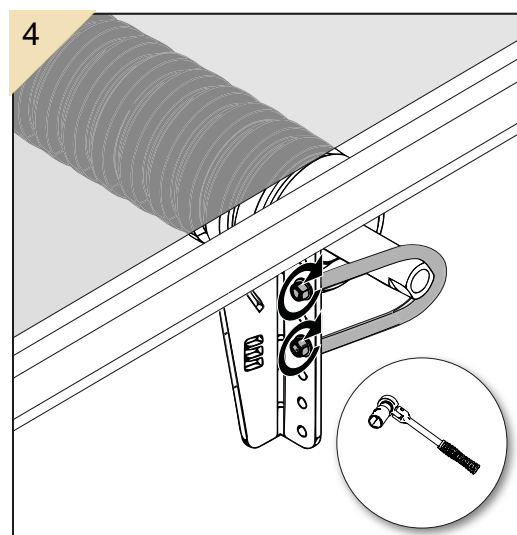
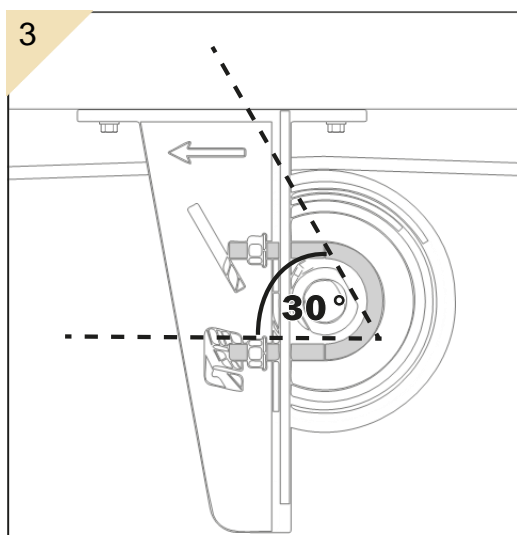
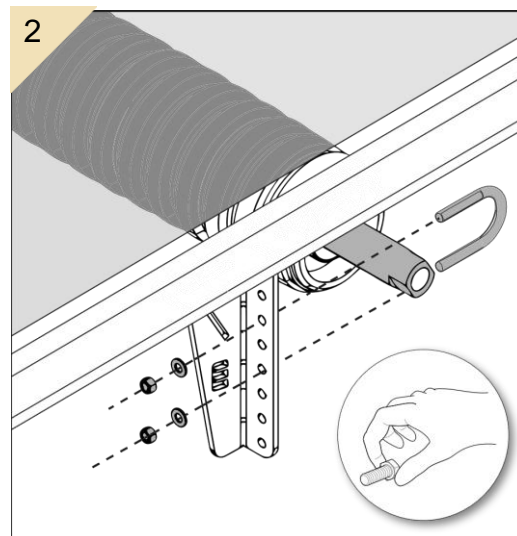
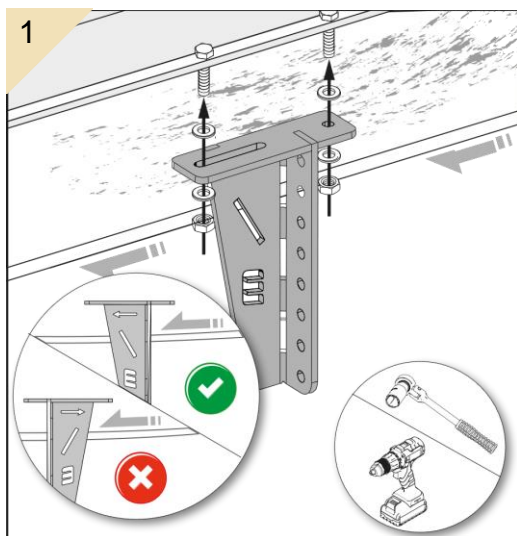

## 4.2 Placing labels

### 4.2.1 Safety label

The safety label below must be attached to the conveyor system in the immediate vicinity of the MRT:



### 4.2.2 Other labels

The labels below are attached to the product:

1. Sticker showing the address of the Martin Engineering branch and the designation of the product

## 5 Maintenance / Repair



### WARNING

#### Danger of injury due to unapproved component parts

Unapproved parts can directly or indirectly cause personal injury or damage to property.

- *Only use accessories and spare parts that are distributed by the manufacturer or are explicitly approved (in writing)!*

interval	task
weekly	Check that all securing parts are tightened. Tighten any loose connections as required.
	Clean all warning labels. Replace any warning labels which are illegible.



### NOTE

Remove equipment from service if there is any indication it is not functioning properly. Call Martin Engineering or representative for assistance. Do NOT return equipment to operation until the cause of the problem has been identified and corrected.

## 6 Disassembly / Recycling / Disposal

---

1. Disassemble MRT by material groups as far as possible.
2. Contact official bodies (disposal centres, authorities) and request information about proper disposal or recycling possibilities.
3. Recycle the different materials.

Only materials that cannot be reasonably recycled may be disposed of. Disposal must be carried out professionally.

Material groups that can be fed into a recycling process include:

- Sheet steel
- Steel profiles
- Plastics
- Rubber
- Non-ferrous metals
- Electrical cables
- Electrical components (with copper content)
- Lubricants





### **France**

Martin Engineering SARL  
50, Avenue d'Alsace, 68025 Colmar Cedex,  
France  
Tel +33 3 89 20 63 24; Fax +33 3 89 20 43 79  
info@martin-eng.fr; www.martin-eng.fr

### **Italy**

Martin Engineering Italy Srl  
Via Buonarroti, 43/A, 20064 Gorgonzola (MI),  
Italy  
Tel +39 02 9538 3851; Fax +39 02 9538 3815  
info@martin-eng.it; www.martin-eng.it

### **Spain**

Martin Engineering Spain  
c/Balmes 297 3° 1ª b 08006 Barcelona, Spain  
Tel. +34 876 245 114  
info@martin-eng.es; www.martin-eng.es

### **United Kingdom**

Martin Engineering Ltd.  
Unit 33, The Tangent Business Hub, Weighbridge  
Road,  
Shirebrook, NG20 8RX, United Kingdom  
Tel +44 115 946 4746  
info@martin-eng.co.uk; www.martin-eng.co.uk

### **Germany**

Martin Engineering GmbH  
In der Rehbach 14, 65396 Walluf, Germany  
Tel. +49 6123 9782-0; Fax +49 6123 7553-3  
info@martin-eng.de; www.martin-eng.de

### **Russia**

OOO Martin Engineering  
Bolshaya Kalitnikovskaya str, 42, office 508,  
Municipal district Tagansky, Moscow, 109029  
Russia  
Tel +7 495 181 33 43; Fax +7 499 720 62 12  
info@martin-eng.ru; www.martin-eng.ru

### **Turkey**

Martin Engineering Türkiye  
Yukarı Dudullu İmes Sanayi Sitesi, B Blok 205  
Sokak No.6  
34775 Ümraniye İstanbul, Turkey  
Tel +90 216 499 34 91  
info@martin-eng.com.tr; www.martin-eng.com.tr