



**PRODUCT CATALOGUE**

L4203UK-P



## Cleaner, Safer, More Productive Bulk Material Handling Since 1944

Founded in 1944, Martin Engineering has grown from a modest family-owned entrepreneurial operation in the United States to the global leader in bulk material handling solutions. With an emphasis on innovation and customer satisfaction, we've developed cutting-edge technologies that improve efficiency, safety, and productivity across various industries. Over the years, we've expanded our reach to every corner of the globe, delivering high-quality products, services, and training to sectors including mining, processing, energy, and transportation.

With over 80 years of experience and proven results, we continue to set industry standards through our ongoing commitment to research and development. Our dedication to solving complex material handling challenges has earned us a trusted reputation with operations worldwide. Whether we're providing solutions to keep conveyor belts clean and aligned, control airborne dust and material spillage, or maintain proper material flow and throughput, our solutions are known for their reliability and performance, enhancing safety and fostering long-term partnerships with our customers across the globe.



Martin Engineering products, sales, service, and training are available from factory-owned facilities worldwide, supplemented by a strategic network of partners.

- United States
- India
- Peru
- Australia
- Indonesia
- Scandinavia & Baltic States
- Brazil
- Italy
- Spain
- Central Asia
- Kazakhstan
- South Africa
- Chile
- Malaysia
- Turkey
- China
- Mexico
- United Kingdom
- Colombia
- Middle East
- France
- North & West Africa
- Germany

### Primary Belt Cleaners

CleanScrape® Primary Cleaner . . . . .	4
QC1+™ Primary Belt Cleaners . . . . .	5
Compact Primary Cleaner . . . . .	6
SHD Series Primary Belt Cleaners . . . . .	6
Tensioners . . . . .	7
Hanger Mounts & Mount Plates . . . . .	7
Belt Cleaner Replacement Blades . . . . .	8

### Secondary Belt Cleaners

CleanScrape® Secondary Cleaner . . . . .	9
SQC2™ Cleaner . . . . .	10
SQC2™ Mini Cleaner . . . . .	10
QC2™ Cleaner . . . . .	10
DT2S Reversing Cleaner . . . . .	11
DT2H Reversing Cleaner XHD . . . . .	11

### Specialty Belt Cleaners

Brush Cleaners . . . . .	12
Washbox™ Belt Cleaning System . . . . .	13
Food Grade Cleaner . . . . .	13

### Pulley Protection Plows

VPlow Modular . . . . .	14
VPlow HD . . . . .	15
Torsion VPlow Plus . . . . .	15
Diagonal Plow . . . . .	15

### Belt Alignment

Tracker™ . . . . .	16
Tracker™ Reversing . . . . .	17
Roller Tracker™ . . . . .	17

### Belt Sealing

ApronSeal™ Skirting . . . . .	18
GravitySeal™ Self-Adjusting Skirting . . . . .	19
External Wear Liner . . . . .	19

### Belt Support

Impact Cradles . . . . .	20
Impact Cradles HD . . . . .	21
Slider Cradle . . . . .	21
Trac-Mount™ Idlers . . . . .	22

### Dust Management

Dust Curtain Double . . . . .	23
Dust Bag . . . . .	23

### Safety Accessories

Inspection Doors . . . . .	24
----------------------------	----

### Air Cannons

Hurricane Air Cannon . . . . .	25
Typhoon Air Cannon . . . . .	26
Tornado Air Cannon . . . . .	26
Blow Pipes . . . . .	26
SMART™ Series Nozzles . . . . .	27
SMART™ Series Retractable Nozzle 360° . . . . .	27
Thermo Safety Shield . . . . .	27
Nozzles . . . . .	28
Mount Plates . . . . .	28
Six Pack Programme . . . . .	28
Air Cannon Controller . . . . .	28

### Services and Training

Walk The Belt™ . . . . .	29
Foundations™ Training . . . . .	29
Foundations™ Book . . . . .	29
Conveyor Safety Book . . . . .	29
N2® Position Indicator . . . . .	30
Resources . . . . .	30
Our partners . . . . .	31

*The products shown in this product catalogue have different approvals and certificates for different regions and requirements. Compliance with legal and regulatory requirements must be checked and ensured in each individual case. If in doubt, please contact your Martin Engineering representative.*



## Primary Belt Cleaners

Martin Engineering belt cleaners are the original standard in engineered belt cleaning. World class manufacturing, robust construction, and the highest-quality urethane on the market deliver unrivalled cleaning performance, durability, and reliability.

Multiple blade, tensioner, and mainframe options available to meet the unique demands of application requirements.

### CleanScape® Primary Cleaner

The CleanScape® Belt Cleaning System introduces a revolutionary innovation in belt cleaning technology.

- Efficient & effective performance
- Lower maintenance as compared to traditional cleaners
- Safe for belts
- Reduces operating costs

CleanScape® is installed diagonally across the discharge pulley and forms a three-dimensional curve.

The cleaner incorporates a matrix of carbide tips and is tensioned across the belt in a specified angle. Despite an extremely low contact pressure between belt and cleaner, any stuck material is removed very efficiently.

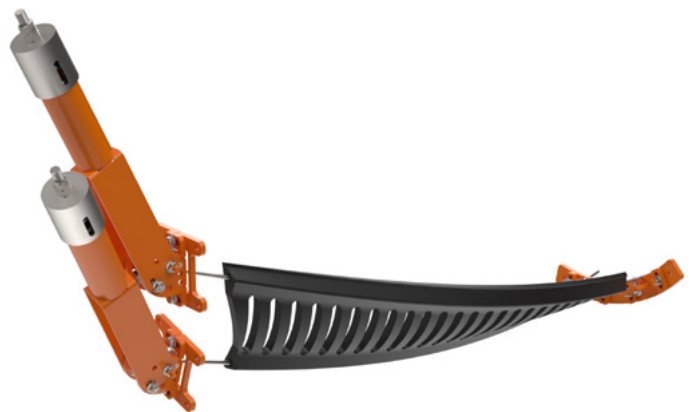

Dimensions	Belt Width (mm)	Pulley Diameter in. (mm)
CSP S	400-1000	300-550
CSP M	500-1800	550-900
CSP L	800-2400	800-1250
CSP H	1000-3000	800-2000

**QC1+™ Primary Belt Cleaners**

Patented constant angle radial pressure (CARP) blades ensure continuous and consistent cleaning performance across all stages of blade life and are available in several specialized urethane formulations to best suit the material being conveyed.

Patented blade holders allow blades to be cut to any length to perfectly match the material path.

Available with 1-piece mainframe and Twist™ or Spring tensioner. Suitable for temperatures ranging from -40 to 150° C, depending on polyurethane type.

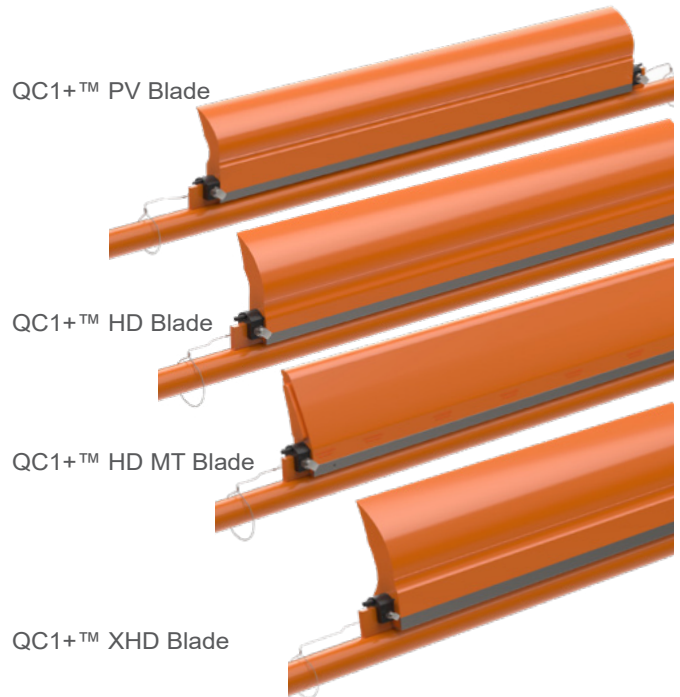

Model	Belt Width (mm)	Max Belt Speed (m/s)	Pulley Diameter (mm)
QC1+™ PV	500-1800	2.5	300-400
QC1+™ HD	500-2400	4.6	300-600
QC1+™ HD MT	500-2400	4.6	300-600
QC1+™ XHD	750-1800	6.1	400-800
QC1+™ XHD D	2000-3000	6.1	400-800

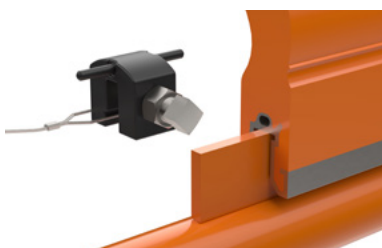

Martin Engineering's patented QC1+™ blade design features a unique mounting interface that takes advantage of blade holders that allow blades to be cut to any length and mounted to the mainframe to perfectly match the material path.

Blades that match the material path of the conveyor system provide the most effective cleaning by ensuring the proper contact with the belt and reducing uneven blade wear and unnecessary wear of the belt surface, extending equipment life.



Visit our online **Foundations™ Learning Centre** for free articles, videos, e-books, and blog posts offering a broad variety of information including selection guides, maintenance checklists, troubleshooting tips and tricks, and much more. >> [foundations.martin-eng.com/en/knowledge](https://foundations.martin-eng.com/en/knowledge)

## PRIMARY BELT CLEANERS

### Compact Primary Cleaner

Designed for applications on small pulleys, the Compact Cleaner offers a low-profile blade mounted on an internal square-profile mainframe for effective belt cleaning in tight spaces.

Available with patented CARP blades in five specialized urethane formulations to best suit the material being conveyed and ensure continuous and consistent cleaning performance across all stages of blade life. Suitable for temperatures ranging from -40 to 150° C, depending on polyurethane type.

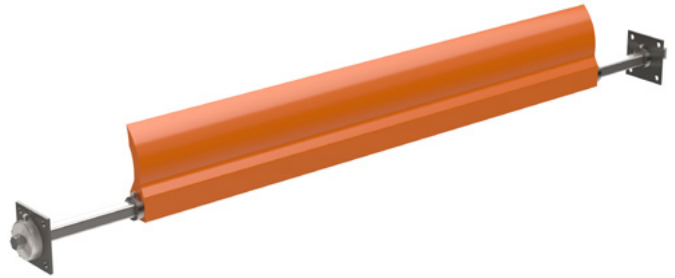

Model	Belt Width (mm)	Max Belt Speed (m/s)	Pulley Diameter (mm)
QC1™ Compact	300-1400	1,8	150-300

### SHD Series Primary Belt Cleaners

Structural steel means no more bent mainframes, even with high tonnages and large lumps.

Massive urethane blades provide up to 305 mm of wear life.

Martin® SHD Cleaner and tensioner are designed together for effective cleaning and reduced service requirements.

Patented 'CARP' (Constant-Angle/Constant-Area Radial Pressure) blade design maintains cleaning performance through all stages of blade life.

Suitable in applications with temperatures ranging from -40 to 150° C, depending on polyurethane type.

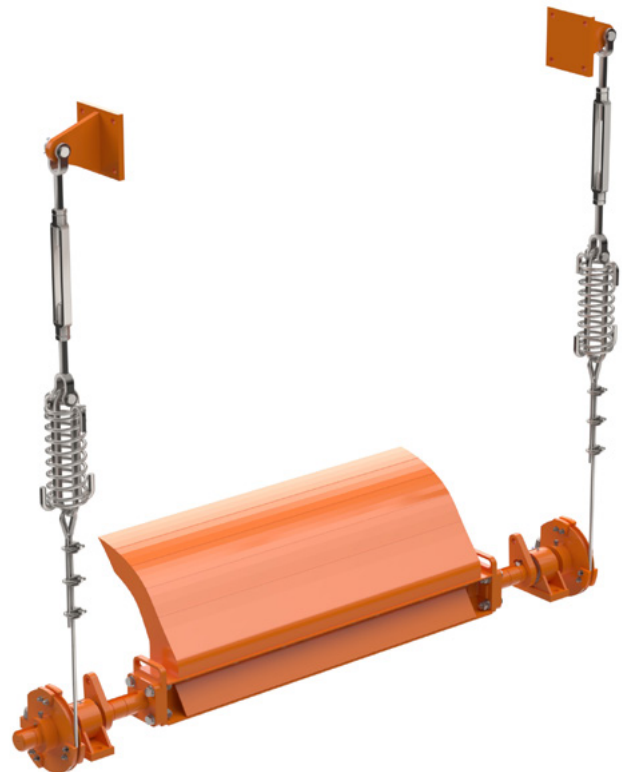

Model	Belt Width (mm)	Max Belt Speed (m/s)	Pulley Diameter (mm)
SHD 600 Series	800-3000	10,0	600-1200
SHD 1200 Series	800-3000	10,0	1200-1800

**Tensioners**

Martin® Belt Cleaner Tensioners provide the most robust and rugged construction to maintain reliable and proper blade-to-belt tension to ensure unmatched belt cleaning performance while providing ease-of-service and minimal maintenance.

The patented Martin® Twist™ Tensioner uses energy from a twisted rubber coupling to supply consistent belt cleaning pressure with minimal adjustment.

The Twist™ Tensioner allows mechanical splices to pass without damage. In the event that the blade pulls through, the tensioner's coupling rolls over, releasing pressure and reducing the risk of harm to personnel or equipment.

Light aluminium housing and the fully-enclosed design keeps the tensioner mechanism clean. Simple adjustment involves twisting the tensioning gear the specified number of notches (determined by belt width). The ratchet will automatically lock in place.

Spring Tensioners maintain efficient belt cleaning with a rugged coil spring providing visibility of the tensioning mechanism.

Dual tensioning is recommended for belt cleaners installed on belts wider than 1400 mm. Mounts and tensioners can be purchased individually or in packages with various belt cleaning systems.



Twist™ Tensioner



Spring Tensioner XHD



Spring Tensioner

**Hanger Mounts & Mount Plates**



Hanger Mount for XHD Spring Tensioner

Hanger Mount for Twist™ Tensioners

Heavy Duty Hanger Mount for Secondary Cleaners



Mount Plate for XHD Spring Tensioners

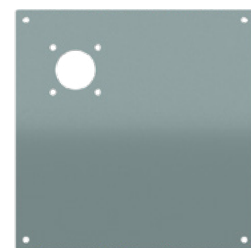

Mount Plate for Twist™ Tensioners



Mount Plate for Twist™ Tensioners

Martin® Hanger Mounts provide the framework to install a conveyor belt cleaner and tensioner assembly on open head-pulley belt conveyors without an enclosed chute, providing the necessary support to achieve and maintain proper and effective cleaning position.

Mount Plates provide the necessary surface with predrilled and cut holes to mount tensioners when adequate chute wall is not available.

## REPLACEMENT BLADES

### Genuine Martin® Belt Cleaner Replacement Blades

One of Martin Engineering's defining characteristics and core strengths is our expertise in urethane formulation and production.

Martin Engineering is the original and industry-leading manufacturer of specialty urethanes for heavy-duty, high-performance belt conveyor components, including belt cleaner blades, chute liners, and impact and support bars. We offer the highest-quality urethane products, formulated and manufactured entirely in-house at our company headquarters in Neponset, Illinois, USA.

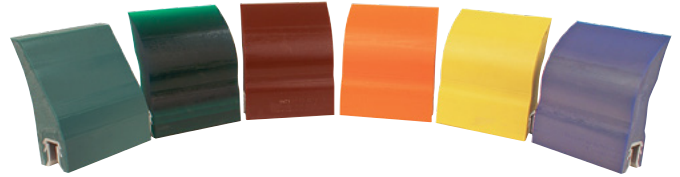

Urethane	Colour	Duro-meter	Application Conditions	Temperature Range
Standard	Orange	83	Suitable for most applications, including abrasive conditions and exposure to solvents or oil. For use with materials such as coal, ore, bauxite, coke, refuse.	-30° to 80°C
High-Temp	Green	83	For use with high temperature materials such as clinker. Can handle intermittent temperatures of 350°F (177°C).	-40° to 150°C
Chemical Resistant	Brown	86	Improved resistance to chemicals and reduces water absorption for high moisture environments such as limestone. Best choice for applications exposed to chemicals with pH as high as 11 and as low as 4.	-40° to 80°C
Low Rigidity	Tan	87	For use with dry products such as sand and gravel.	-30° to 80°C
Low Adhesion	Navy Blue	91	For use with sticky or tacky products such as cement, glass, and wood chips.	-30° to 80°C

Our unrivalled product quality is informed by decades of research and development and ensured by our state-of-the-art production process completed start-to-finish under one roof by the industry's foremost experts.

Martin Engineering's unique CARP blade design provides Constant Angle Radial Pressure to ensure consistent cleaning throughout the entire wear life of the blade, maximizing return

on your investment and delivering unrivalled reliability without degradation in performance. Specially-formulated, color-coded urethanes are available to best suit any application.



Visit our **On-Demand Webinar Library** for dozens of free on-demand video recordings covering a wide variety of topics including belt conveyor optimization, carryback and belt cleaning, material flow, dust control, and safety and culture. >> [foundations.martin-eng.com/webinars-on-demand](https://foundations.martin-eng.com/webinars-on-demand)



## Secondary Belt Cleaners

Secondary cleaners are installed with the cleaning edge at a scraping angle with high blade-to-belt pressure behind the head pulley where the belt is at its flattest, providing an ideal surface to effectively clean.

Secondary cleaners are much better suited to scrape off the remaining smaller particles and higher-moisture carryback that primary cleaners can't remove. A properly specified, installed, and maintained multiple-cleaner system can reliably achieve 90 to 95% carryback removal from the conveyor belt.

### CleanScrape® Secondary Cleaner

The CleanScrape® Secondary Cleaner is available in stainless steel or partly mild steel assembly featuring independent 6-inch wide blades with carbide tips. Each blade tip is supported on spring loaded arms at both ends. The load springs allow independent blade rotation back and forward as well as up and down.

This range of motion provides equal load pressure across each blade, absorbs obstructions, conforms to ever-changing belt undulations, and arcs safely in the event of belt rollback.

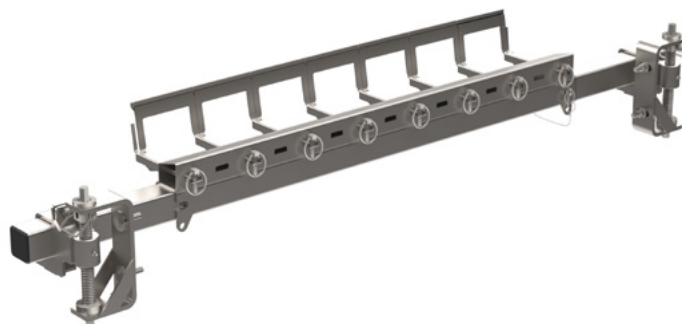

Belt Width (mm)	Max Belt Speed (m/s)		Temperature (C)
	5.0 for vulcanized splices	3.0 for mechanical splices	
500-2600			-40 - 315 °C for stainless steel mainframe -40 - 150 °C for mild steel mainframe

## SECONDARY BELT CLEANERS

### SQC2™ Cleaner

The most versatile and best-selling secondary cleaner on the market, SQC2™ is a reliable and proven solution for a broad range of demanding applications across virtually every industry. Its rugged construction withstands harsh environments, high-speed belts, and high-tonnage loads.

Individually-cushioned tungsten carbide blades deliver effective and reliable cleaning performance without risk to belt, splice or blade. Rubber blade buffers cushion the impact of each blade individually, maintaining consistent cleaning pressure. Blade cartridge allows quick and easy removal of all blade segments for rapid return to service. Compact design allows installation in tight spaces while narrow profile resists material build-up.

Available with acid-resistant tips. Blade buffers available in moulded rubber and flame-retardant rubber.

Scorpio Blade

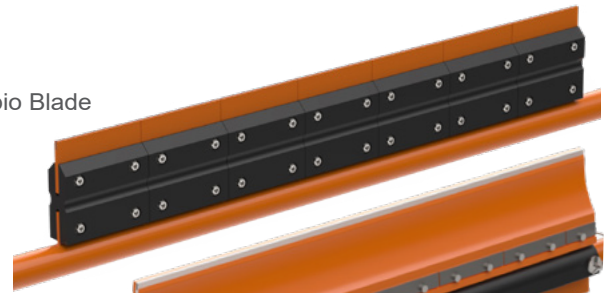

SAF Blade

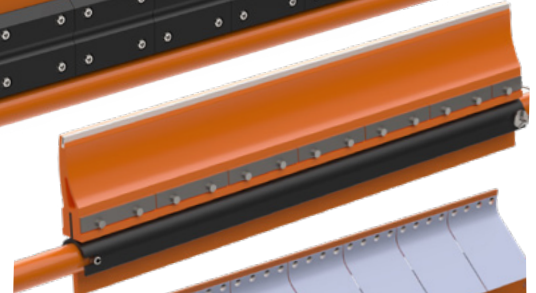

Orion Blade

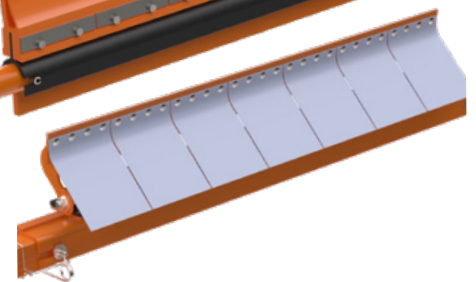

Model	Belt Width (mm)	Max Belt Speed (m/s)	Temperature (C)
SQC2™	450-3000	5,1	-30° to 95°
SQC2™ SAF	500-2400	3,5	-40° to 150°
SQC2™ ORION	500-2600	5,1	-30° to 121°

### SQC2™ Mini Cleaner

Compact design allows installation in close quarters while the narrow profile resists material buildup.

Individually-cushioned tungsten carbide blades deliver effective and reliable cleaning performance while cushioning impact and accommodating reversing belt direction, eliminating risk to the belt, splice, or blade.



Belt Width (mm)	Max Belt Speed (m/s)	Temperature (C)
450-3000	5,1	-30° to 95°

### QC2™ Cleaner

The QC™ 2 secondary cleaner combines a unique droplet-shaped blade with a tungsten-carbide blade edge and linear spring tension, thus enabling long wear lives with maximum cleaning performance without high investments.

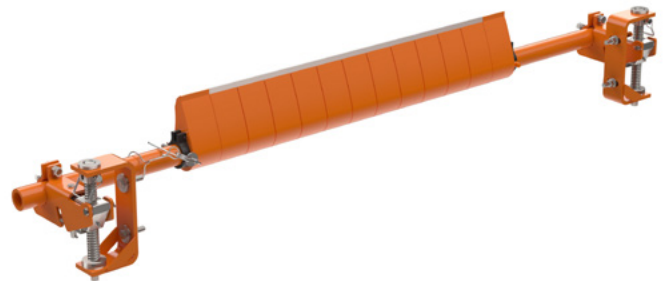

Belt Width (mm)	Max Belt Speed (m/s)	Temperature (C)
500-3000	5,1	-40 to 150°C

**DT2S Reversing Cleaner**

Combining the best features of the two preceding designs, the DT2S Reversing Cleaner features a split-track blade cartridge that slides in and out on a stainless steel mandrel. This unique design makes for a fast and easy service procedure to reduce conveyor downtime.

Lean profile minimizes space requirements, allowing installation in spaces as narrow as seven inches (178 mm).



Belt Width (mm)	Max Belt Speed (m/s)	Temperature (C)
500-3000	4,3	-40 to 150°C

**DT2H Reversing Cleaner XHD**

Features rugged blades installed on a track that slides into cleaning position on a rugged steel mandrel. This unique design makes for a quick and easy service procedure that reduces conveyor downtime and improves productivity.

Massive extra-heavy duty (XHD) blades stand up to challenging conditions, including heavy material loads and high belt speeds.



Belt Width (mm)	Max Belt Speed (m/s)	Temperature (C)
500-2400	6,1	-40° to 150°



Visit our website to download our **Foundations™ Books**, industry-standard textbooks for cleaner, safer, and more productive conveyor operation and maintenance, along with e-books covering a variety of specific bulk material handling and material flow topics. >> [foundations.martin-eng.com/book-options](https://foundations.martin-eng.com/book-options)



## Specialty Belt Cleaners

Installed mainly as secondary belt cleaners, Martin Engineering's specialty belt cleaners include products engineered to perform under the most challenging conditions, such as extreme temperatures, as well as suited for food grade applications. Products are also available that perform with varying types of belts, including ribbed, flighted, grooved, or chevron conveyor belts.

### Brush Cleaners

Effective cleaning performance on difficult applications, including belts with ribs, cleats, grooves, or chevrons, or belts carrying sticky materials or stringy fibres.

Efficient electric motor provides effective cleaning with powered rotary action without excessive power consumption. Durable angle iron and stainless steel components provide long service in tough conditions.

Strip Brush Cleaner uses 12 brush strips assembled on a series of hubs mounted on a shaft to form a 10-inch diameter brush. Strip brush design allows material to fall off the brush rather than settle into the bottom of the bristles. Design allows simple replacement of individual brush strips.

Spiral Brush Cleaner features bristles wrapped in a continuous spiral around brush shaft to deliver effective cleaning performance on dry fines clinging to belts with cleats, chevrons, or ribs.



Belt Width (mm)	Max Belt Speed (m/s)	Temperature (C)
500-2000	2,5	-20 to 60°C

### Washbox™ Belt Cleaning System

Installed as a secondary cleaner along the conveyor's return run, the Martin® Washbox™ Cleaning System provides the ultimate in belt cleaning technology. Each Martin® Washbox™ Cleaning System can be custom-engineered to match your cleaning requirements.

Martin® Washbox™ Spray Wash Systems are designed for use in applications where the conveyor belt must be very clean. As the belt enters the Washbox™ a set of return idlers stabilise the belt. A spray bar uniformly sprays the belt with water.

The dual secondary belt cleaner removes most of the material from the belt. The remaining material is removed by the third secondary belt cleaner.



Belt Width (mm)	Max Belt Speed (m/s)	Temperature (C)
500-2200	5,1	-30 to 95°C



Visit our online **Foundations™ Learning Centre** for free articles, videos, e-books, and blog posts offering a broad variety of information including selection guides, maintenance checklists, troubleshooting tips and tricks, and much more. >> [foundations.martin-eng.com/en/knowledge](https://foundations.martin-eng.com/en/knowledge)

### Food Grade Cleaner

Martin® Food Grade Belt Cleaner fits requirements of belt conveyors in food processing and packaging. Available as either a primary or secondary cleaner with high-density polyethylene or nylon blades on stainless steel mainframes with either an air, spring, or hub mount tensioner.

Belt Width (mm)	Max Belt Speed (m/s)	Temperature (C)
100-1200	1.8	-40° to 193°





## Pulley Protection Plows

Martin Engineering's tail protection products are designed to prevent material that has landed on the inside of the belt during the return from being pulled into the tail pulley. If it isn't removed, the material can cause extensive damage to the entire conveyor system, especially the tail pulley and the belt.

Our tail protection products, which are designed to plow discharge material to the side of the belt for easy control and cleanup, are available for standard and reversing belts, with self-adjusting models that rise and fall with fluctuations in belt tension. We also offer products designed for varying speeds and belt widths.

### VPlow Modular

The VPlow is an effective and economical solution for belt and pulley protection from medium- to heavy-duty applications. The VPlow floats on the inside surface of a conveyor belt to reliably remove stray material. The self-adjusting design provides effective cleaning through all stages of blade wear.

Low-profile rugged steel frame construction bolts together for easy installation and stands up to the toughest applications.

Easily replaceable blades are available in long-wearing 90 Shore A Durometer urethanes to match application and material requirements. Tough one-piece urethane bull nose provides long-lasting life and easy replacement.



Belt Width (mm)	Max Belt Speed (m/s)	Temperature (C)	Wearable Blade (mm)
500-3000	4,6	-40 to 150°C	50



Visit our **On-Demand Webinar Library** for dozens of free on-demand video recordings covering a wide variety of topics including belt conveyor optimization, carryback and belt cleaning, material flow, dust control, and safety and culture. >> [foundations.martin-eng.com/webinars-on-demand](https://foundations.martin-eng.com/webinars-on-demand)

### VPlow HD

The VPlow is an effective and economical solution for belt and pulley protection in heavy-duty applications. The VPlow floats on the inside surface of a conveyor belt to reliably remove stray material. The self-adjusting design provides effective cleaning through all stages of blade wear.

Low-profile rugged steel frame construction bolts together for easy installation and stands up to the toughest applications.

Easily replaceable blades are available in long-wearing 90 Shore A Durometer urethanes to match application and material requirements. Tough one-piece urethane bull nose provides long-lasting life and easy replacement.

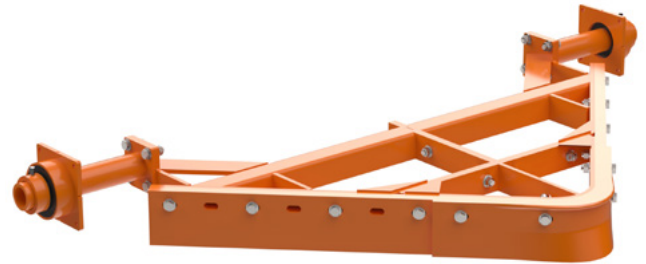

Belt Width (mm)	Max Belt Speed (m/s)	Temperature (C)	Wearable Blade (mm)
1200-3000	5,1	-40 to 150°C	50

### Torsion VPlow Plus

The Martin® Torsion VPlow Plus is mounted with a unique yet simple two-point centre mount suspension that provides both constant positive pressure and maximum flexibility to allow the plow to rise and fall with fluctuations in belt tension and travel. This self-adjusting function provides the most effective and reliable cleaning through all stages of blade wear.

Low-profile rugged steel frame construction bolts together for easy installation and stands up to the toughest applications.

Easily replaceable blades are available in long-wearing 90 Shore A Durometer urethanes to match application and material requirements. Tough one-piece urethane bull nose provides long-lasting life and easy replacement.



Belt Width (mm)	Max Belt Speed (m/s)	Temperature (C)	Wearable Blade (mm)
500-3000	4,6	-40 to 150°C	50

### Diagonal Plow

Hung from brackets on both sides of the conveyor, the Martin® Diagonal Plow floats on the belt surface to remove material without needing adjustment. The sturdy PU blades with 90 Shore A hardness provides 1.5 in. (38 mm) of wear in service temperatures to 121°C and belt speeds up to 4.6 m/sec.

Alternatively, rubber blades can be supplied.

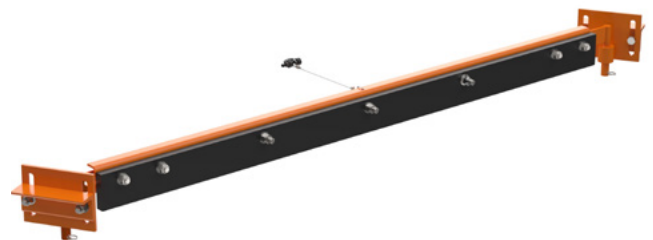

Belt Width (mm)	Max Belt Speed (m/s)	Temperature (C)	Wearable Blade (mm)
500-3000	4,6	-40 to 150°C	38



## Belt Alignment

By keeping belts tracked correctly, you can keep material in the flow stream and eliminate runaway dust. Martin Engineering's belt alignment products provide immediate, continuous precision adjustment that keeps conveyor belts perfectly aligned, even withstanding the stress caused by wider, thicker belts carrying heavier loads at high speeds.

Our belt tracking products prevent edge damage, extend belt life, reduce spillage, and minimize wear and tear on equipment. Plus, we manufacture trackers that can sense the direction of the belt's movement and make the adjustments needed to keep reversing conveyors correctly centred.

### Tracker™

The Martin® Tracker™ is the most reliable and effective solution to provide immediate and continuous precision adjustment for wandering conveyor belts.

Unlike other belt training devices, the Tracker™ excels in reducing edge damage, preventing spillage, and extending belt life. Its automatic, continuous adjustments keep the belt in consistent alignment, ensuring improved tracking that significantly reduces maintenance expenses.

The Tracker™ features a patented parallel steering/training system for precise, ongoing adjustment, maintaining optimal belt alignment and operational efficiency at all times.

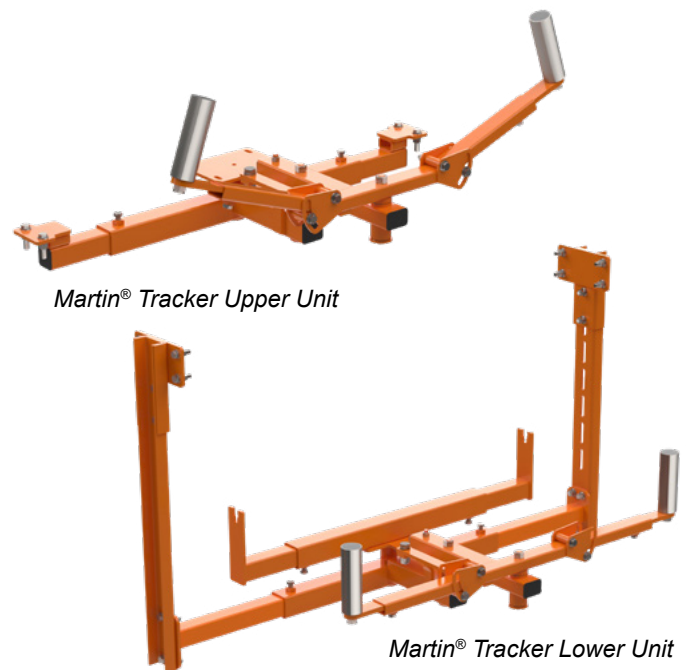

*Martin® Tracker Upper Unit*

*Martin® Tracker Lower Unit*

Belt Width (mm)	Max Belt Speed (m/s)	Temperature (C)
600-2000	5,0	-30 to 60°C

## Tracker™ Reversing

The Martin® Tracker™ Reversing is a state-of-the-art solution offering immediate and continuous precision adjustment for reversing conveyors that are challenging to track. This innovative system ensures the belt stays perfectly centred regardless of its direction of travel.

The Tracker™ Reversing is equipped with sensing rollers and lever arms at both ends and utilizes a stainless steel lamella, or paddle wheel, to accurately detect the belt's direction and activate the appropriate sensing rollers.

This advanced technology guarantees optimal belt alignment, enhancing operational efficiency and reducing maintenance needs for reversing conveyor systems.

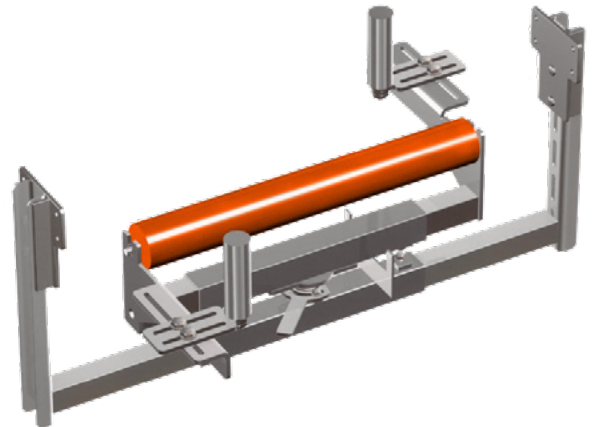

Belt Width (mm)	Max Belt Speed (m/s)	Temperature (C)
600-1700	3,5	-30 to 60°C



Visit our website to download our **Foundations™ Books**, industry-standard textbooks for cleaner, safer, and more productive conveyor operation and maintenance, along with e-books covering a variety of specific bulk material handling and material flow topics. >> [foundations.martin-eng.com/book-options](https://foundations.martin-eng.com/book-options)

## Roller Tracker™

The Martin® Roller Tracker™ is engineered to meet the rigorous demands of conveyor belt tracking with unparalleled precision and reliability.

Designed for ease of installation and minimal maintenance, it ensures a smooth, vibration-free rolling action that enhances operational efficiency. Featuring superior bearings for exceptional quality, the Roller Tracker™ guarantees reliable performance tailored to customer needs on belt widths from 500 to 1600 mm.

Its innovative design eliminates contact with the belt edge, preventing wear and extending belt life. With polyurethane lagging enhancing durability, this tracker delivers long-lasting reliability and optimal belt alignment. Suitable for reversing belts.

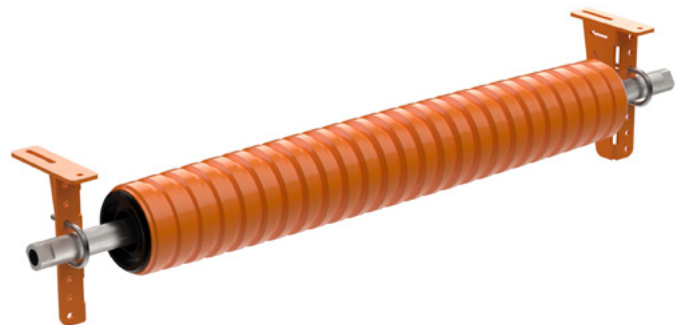

Belt Width (mm)	Max Belt Speed (m/s)	Temperature (C)
500-1600	5,0	-30 to 60°C



## Belt Sealing

Martin Engineering's ApronSeal™ Skirting products are engineered for superior performance in demanding material handling environments. Featuring an innovative dual-sealing design, ApronSeal™ effectively contains airborne dust and mitigates material spillage along conveyor belts. This innovative system requires minimal maintenance and maximizes operational efficiency, safeguarding both workers and equipment. Ideal for applications requiring stringent dust control, ApronSeal™ sets a new standard in conveyor belt skirt sealing, delivering unparalleled reliability and performance.

### ApronSeal™ Skirting

Martin® ApronSeal™ Skirting provides dual-seal efficiency with a single, one-piece sealing strip for any troughing angle to prevent the escape of fines and dust. The primary seal is clamped to the chute wall with the self-adjusting secondary seal laying outward to create an effective dust seal that is out of the material flow. ApronSeal™ Skirting requires minimal service to maintain an effective seal.

ApronSeal™ Double Skirting uses a patented design that features a reversible elastomer strip to provide a second wear life. Optional quick-release clamps are available. Suitable for application temperatures from -30° to 121°C.

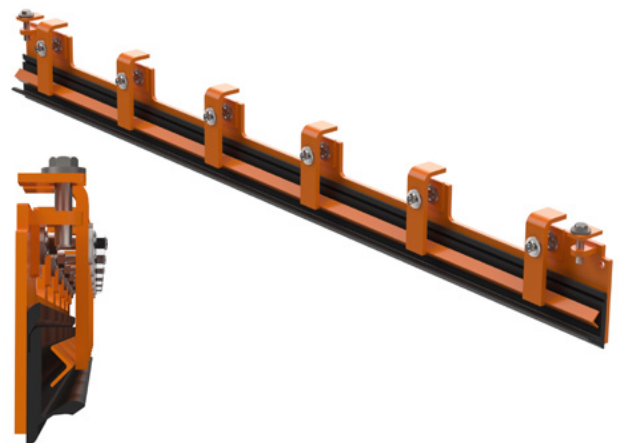

Model	Max Belt Speed (m/s)
Single	3.0
Single HD	3.8
Single XHD	3.8
Double	3.0
Double HD	3.8

Minimum Free Belt Area – (mm)					
Trough Angle	Single	Single HD	Single XHD	Double	Double HD
0°	54	76	89	54	76
20°	66	95	108	66	95
35°	73	106	121	73	106
45°	77	111	127	77	111

## GravitySeal™ Self-Adjusting Skirting

Martin® GravitySeal™ Self-Adjusting Skirting provides an effective skirtboard seal that eliminates spillage and prevents the problems caused by fugitive material.

It self-adjusts to eliminate skirtboard maintenance. Requiring only 38 mm of free belt space outside the chute, GravitySeal™ Self-Adjusting Skirting is the ideal sealing system for conveyors with chutes close to the belt edge. The rubber and clamp assembly can be installed in spaces as low as 150 mm above the belt.

Durable sealing strip provides wear life of two inches (51 mm). Replacement of a worn sealing strip is a quick and easy operation; just remove the linchpins and replace the pre-punched rubber strip.

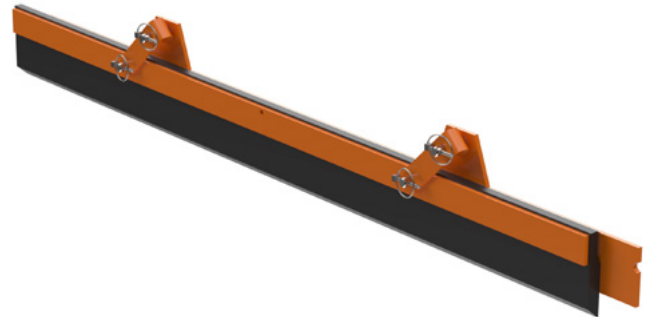

Max Belt Speed (m/s)	Trough Angle	Temp Range (C)
3.0	0 - 45	-30° to 121°



Visit our online **Foundations™ Learning Centre** for free articles, videos, e-books, and blog posts offering a broad variety of information including selection guides, maintenance checklists, troubleshooting tips and tricks, and much more. >> [foundations.martin-eng.com/en/knowledge](https://foundations.martin-eng.com/en/knowledge)

## External Wear Liner

External Wear Liner is installed on the outside of the chute wall, simplifying wear liner inspection and replacement — both without confined-space entry. Improves liner and skirtboard sealing system performance without adding additional conveyor construction cost. The chute wall can be trimmed to avoid material buildup.

Available as low profile and in a variety of materials and thicknesses. Fits conveyors with trough angles from flat to 35°.

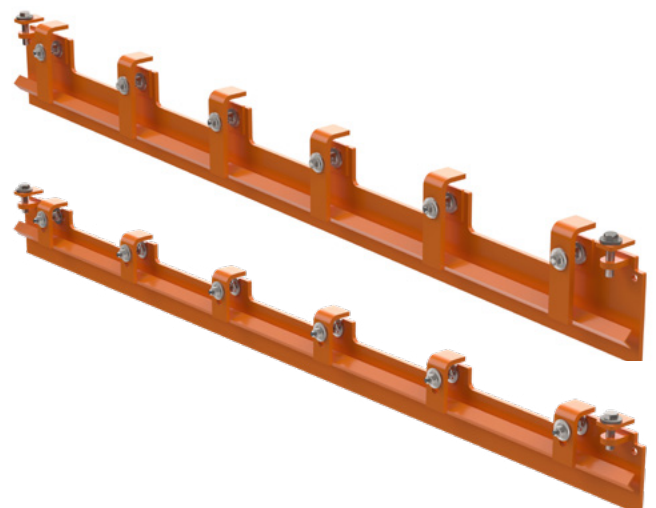

Max Belt Speed (m/s)	Trough Angle	Temp Range (C)
N/A	0 - 35	-30° to 150°



## Belt Support

By providing reliable belt support, especially at transfer points, our products effectively minimize damage and extend the lifespan of your equipment. Martin Engineering's belt support solutions absorb the impact of material falling at transfer points, reducing wear on belts and structures. This proactive approach also prevents belt sag and reduces fugitive material and airborne dust, which pose significant health and safety risks.

Martin Engineering's belt support products are versatile, available for various belt widths, and can be customized to meet specific requirements as needed.

## Impact Cradles

Our robust conveyor belt support cradles are engineered to safeguard your conveyor system with unparalleled durability. These cradles ensure stable belt alignment, effectively preventing damage and minimizing airborne dust and material spillage. Ideal for enhancing operational efficiency and safety, our cradles maintain a consistent belt line, reducing maintenance costs and optimizing productivity in industrial environments.

The Martin® MD Impact Cradle and Martin® LD Impact Cradle are dimensionally adapted to metric conveyor systems and can be combined with European Martin® Slider Cradles and Martin® Trac-Mount™ Idlers.

Adjustment options for height (by using shims of different sizes) width (by slotted holes on the bottom side of the cross beams) and troughing angle eliminate the need for customisation for most applications.

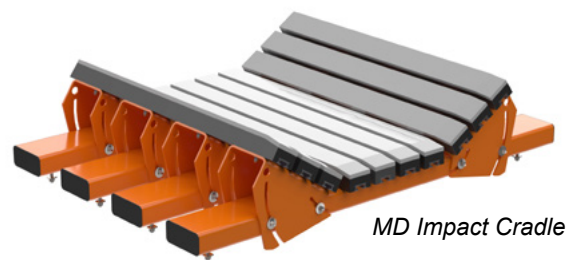

MD Impact Cradle

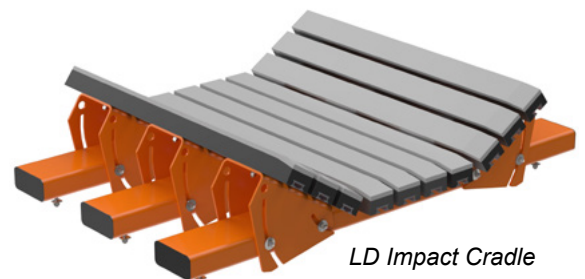

LD Impact Cradle

Belt Width (mm)	Trough Angles	Max Belt Speed (m/s)	Temp Range (C)	Reversing Operation
500-1800	10° - 45°	3,3	-30° to 80°	Yes

### Impact Cradles HD

Martin® robust conveyor belt support cradles are engineered to safeguard your conveyor system with unparalleled durability. These cradles ensure stable belt alignment, effectively preventing damage and minimizing airborne dust and material spillage. Ideal for enhancing operational efficiency and safety, our cradles maintain a consistent belt line, reducing maintenance costs and optimizing productivity in industrial environments.



Belt Width (mm)	Trough Angles	Max Belt Speed (m/s)	Temp Range (C)	Reversing Operation
1000-2000	0° - 45°	3,8	-30° to 80°	Yes

### Slider Cradle

Installed under the skirtboard of a transfer point, Martin® Slider Cradles support the edges of the belt to eliminate sag. These cradles prevent transfer point spillage by stabilizing the belt's path and allow effective sealing of the belt edge. Cradles are available with single or double adjustable high-performance UHMW Bars to match application requirements.

The Martin® Slider Cradles are dimensionally adapted to metric conveyor systems and can be combined with European Martin® Impact Cradles and Martin® TracMount™ Idlers.

Cradles can be easily adjusted to fit any troughing angle between 0° to 45°. Additional options available on request to meet diverse application requirements.



Single Bar



Double Bar with Centre Support Rollers

Belt Width (mm)	Trough Angles	Max Belt Speed (m/s)	Temp Range (C)	Reversing Operation
500-1800	0° - 45°	3,5	-30° to 60°	Yes

## BELT SUPPORT

### Trac-Mount™ Idlers

Trac-Mount™ Idlers utilize sliding frames on a stationary base to provide an idler set that will fit in tight spaces between belt support cradles and allows easy installation and service. Trac-Mount™ Idlers are available with standard frames and utilize impact or steel rolls.

Slide-out/slide-in roller frames allows idler service without need to raise belt or remove adjacent idlers.

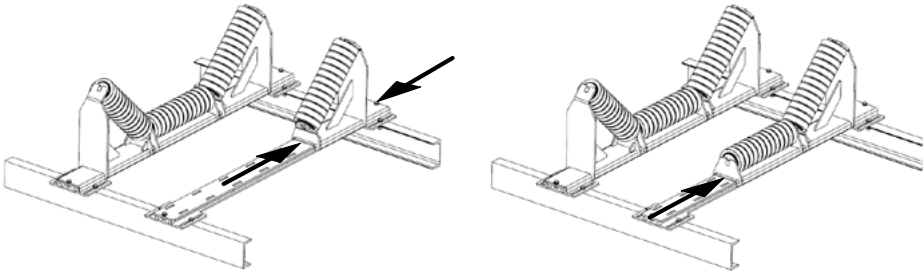



## Dust Management

In bulk material handling operations, one of the most significant sources of dust is the belt conveyor transfer point. Dust is generated as bulk material is transferred from one belt to another. When material is in free fall, it is exposed to significant airflow. This airflow, with enough velocity, carries dust until it slows and settles.

The most effective approach to reducing dust at conveyor load zones is to eliminate dust at the source.

### Dust Curtain Double

Installed at the exit of the loading zone, Martin® Dust Curtain Double provides effective sealing to prevent the escape of airborne fines. Mounted in the skirtboard cover, the dust curtains help create a plenum for dust suppression and dust collection. Recommended installation is one curtain without slits closest to loading zone, followed by one curtain with slits at exit of skirtboard. Additional curtains may be installed to reduce air movement and isolate dust suppression or dust collection systems.

Curtain Material	SBR Rubber 60 durometer
Curtain Width:	Belt width minus 100 mm
Frame Width:	Belt width plus 12 mm

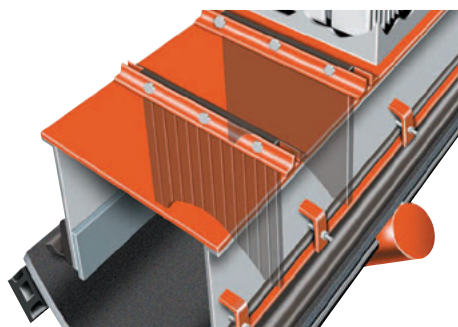
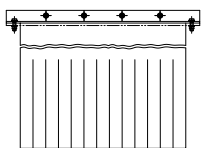

### Dust Bag

A Dust Bag is a passive dust collection system installed above the loading zone to capture dust without an energy-consuming fan. When loading stops, the bag relaxes to return material to the belt. Satin nylon construction withstands positive pressure. Both standard and static-dissipating options are available.

Bag Size (mm)	Airflow (l/minute)
300	Up to 12,750
600	Greater than 12,750





## Safety Accessories

Martin Engineering's area guards and roll baskets provide effective engineering controls to achieve regulatory compliance and help keep workers safe from pinch points and overhead hazards around belt conveyor systems.

Martin Engineering's broad range of inspection doors, available in a wide selection of sizes and with options to match application requirements, provide inspection and access points where needed while also effectively and safely sealing and containing airborne dust.

### Inspection Doors

The Martin® Inspection Door is dust-tight and allows inspection and access in chutes and other enclosures for belt cleaner maintenance or other service requirements.

The sturdy, low-profile design features a dust-tight rubber seal and can withstand typical positive and negative pressure applications. Simple installation allows doors to either be bolted or welded to the enclosure wall. The internal guard screen restricts access and prevent workers from breaking the plane.

Available in mild steel or stainless steel.

The inspection doors can be used in temperatures from -30°C up to +80°C. Various sizes are available depending on the needs

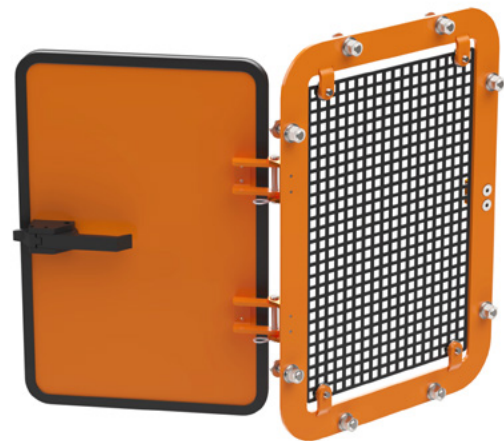

Visit our **On-Demand Webinar Library** for dozens of free on-demand video recordings covering a wide variety of topics including belt conveyor optimization, carryback and belt cleaning, material flow, dust control, and safety and culture. >> [foundations.martin-eng.com/webinars-on-demand](https://foundations.martin-eng.com/webinars-on-demand)



50+  
YEARS OF  
AIR CANNONS

## Air Cannons

Martin Engineering's air cannons apply precisely timed bursts of compressed air to prevent material buildup on interior container walls and obstructions at discharge ports.

Ensuring proper material flow and mitigating buildup avoids unplanned downtime, lost production, and the time and hazards involved with manual cleaning while helping maximize designed production capacity.

### Hurricane Air Cannon

The Hurricane Air Cannon features an advanced positive pressure, positive firing valve concept that provides more force, uses less air, and simplifies installation and maintenance.

Highly effective discharge strength from high velocity output requires half the air volume of standard air cannons, reducing operating costs.

The complete valve assembly can be removed in one easy step, working from one side of the tank. It can be replaced within minutes to keep your process running. There is no need to ever remove the tank from the vessel for service.

Positive-acting valve eliminates the risk of an accidental discharge while allowing the control solenoid to be positioned as far as 200 feet (60 m) from the tank, keeping solenoids away from harsh conditions and difficult-to-service areas.

Available with 35, 70, and 150L tanks.



Visit our website to download our **Foundations™ Books**, industry-standard textbooks for cleaner, safer, and more productive conveyor operation and maintenance, along with e-books covering a variety of specific bulk material handling and material flow topics. >> [foundations.martin-eng.com/book-options](https://foundations.martin-eng.com/book-options)

## AIR CANNONS

### Typhoon Air Cannon

The Typhoon Air Cannon features a hybrid valve concept that provides more force, uses less air, and simplifies maintenance in challenging applications with limited budgets.

Highly effective discharge strength from high velocity output requires half the air volume of standard air cannons, reducing operating costs.

The complete valve assembly can be removed in one easy step, working from one side of the tank. It can be replaced within minutes to keep your process running. There is no need to ever remove the tank from the vessel for service.

Negative pressure firing provides effective performance in challenging applications with limited budgets. Upgrades existing older technology air cannons using normally-open solenoids without the need for replumbing the system.

Available with 35, 70, and 150L tanks.



### Tornado Air Cannon

The Tornado Air Cannon produces better material flow with greater force, faster cycling, and improved safety, firing when the exhaust valve opens in response to a positive surge of air sent by a tripped solenoid valve.

Available in two tank sizes, with a retrofit valve also available, the Tornado Air Cannon is a versatile solution suitable for smaller applications.



### Blow Pipes

This simple pipe solution can be installed at 90 degrees or any custom angle to suit your needs. It comes in mild steel for ambient applications and stainless steel for high-temperature environments. Reliable, versatile, and designed to meet various industrial requirements.

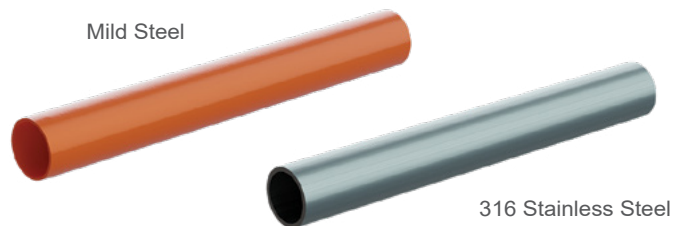

**SMART™ Series Nozzles**

The innovative design of SMART™ Series Nozzles eliminates damage to refractory and makes it possible to maintain nozzles without removing air cannons.

Eliminates the time and cost of cutting holes and breaking refractory to replace worn out nozzles.

Replacement is quick and easy; no entry required into the tower or cooler and no need to remove the air cannon tank.

Eliminates improper alignment and provides a wider area of influence than a standard fan nozzle.

Available in straight or “Y” pipe arrangement.



Y pipe



Straight Nozzle



360° Jet Nozzle



180° Jet Nozzle



90° Jet Nozzle



45° Jet Nozzle

**SMART™ Series Retractable Nozzle 360°**

The SMART™ Series Retractable Nozzle 360° extends service life in preheater towers and high-temperature/high-dust applications by pulling the discharge inside the vessel.

The nozzle extends to fire then retracts to protect the exposed tip from extreme heat. Provides 360° of effective cleaning area, making cleaning the centre of the wall possible.

The 360° nozzle weldment is serviceable from the outside of the riser duct, so nozzle assembly replacements don't have to wait until the next scheduled outage.

Works with standard air cannons (150L Martin® Hurricane is recommended) and is controlled by a single solenoid.



**Thermo Safety Shield**

The Thermo Safety Shield is a slide gate that bolts between an air cannon valve and mounting flange, acting as a safety barrier to allow timely and safe maintenance of air cannon systems. It protects employees from exposure to severe heat, gases, and high temperature material so that maintenance takes place safely and production stays on schedule. The sliding shield operates under tough conditions, yet can be locked out to prevent intrusion.

Available for any air cannon with 4-inch discharge.

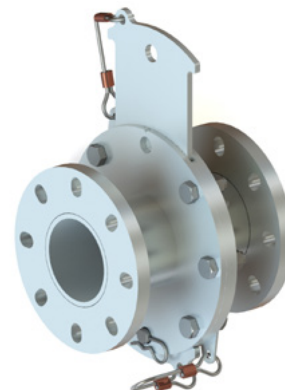

## NOZZLES AND ACCESSORIES

### Nozzles

This product is perfect for cleaning flat surfaces on ductwork, chutes, rock boxes, precipitators, and SCRs. It is versatile and can be used wherever material needs to be reintroduced into the process. The design ensures efficient cleaning and material flow. Ideal for maintaining operational efficiency in various industrial settings.



### Mount Plates

This product is ideal for use on bins, hoppers, and silos. Its 30-degree angle efficiently directs flow toward the outlet of standard vessels. The drop-through version is specifically designed to penetrate liners such as stainless steel or wear plates. This ensures smooth material flow and prevents blockages.



### Air Cannon Controller

Energizes solenoid valves to control the automatic sequencing and discharge for a system of up to ten Martin® Air Cannons.

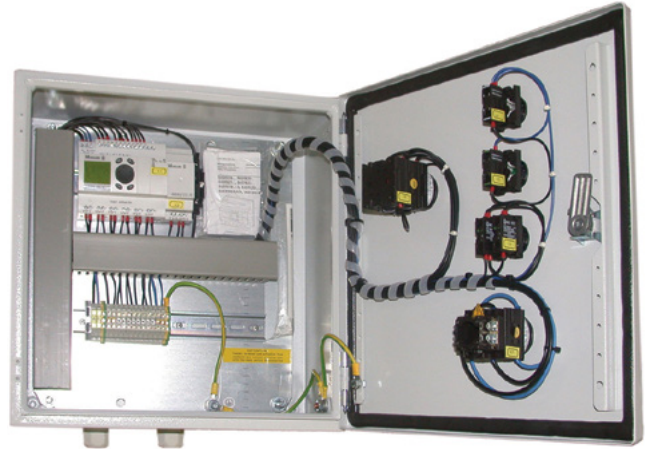

Firing schedule adjustable from one second to 18 hours. Remote dry contact allows timer to be actuated by motor control, flow switch, or manual switch. Available as single circuit and multiple circuit units.

### Six Pack Programme

Martin Engineering offers a "6 pack" of refurbished Hurricane or Typhoon replacement valves to stock on your shelf. Guaranteed against defects, refurbished valves carry the full factory warranty.

Comes in a standard pallet-sized container to refill with worn-out valves and send back to Martin Engineering to be refilled with refurbished valves and returned to you.

Only one part to stock in your warehouse. 10-minute change out. Eliminates purchasing repair kits & the labour to rebuild them.



*The product appearance may differ*



## Services and Training

At Martin Engineering, we offer a variety of services and training to enhance the efficiency, safety, and lifespan of your bulk material handling systems. From conveyor inspections and maintenance programmes like Walk the Belt™ and Mr. Blade® to addressing issues such as dust control and belt tracking, our goal is to optimize your operations. We also provide comprehensive training—whether on-site or online—to equip your team with the knowledge they need for maintaining equipment and following best practices.

### Walk The Belt™

This programme offers free, customized conveyor system inspections to identify and address issues like carryback, mistracking, and dust. These inspections are conducted by highly-trained technicians, who then provide a detailed report with recommendations to improve performance and extend equipment life. This proactive maintenance approach reduces unscheduled downtime and enhances safety, allowing plant managers to focus on core operations.

### Foundations™ Training

Martin Engineering's Foundations™ training programme was conceived as a way to package our accumulated knowledge and deliver it in an impactful, engaging way. Classes are based on our two highly-regarded books, *Foundations™* and *Foundations™ for Conveyor Safety*. The programme addresses many key topics to improve safety and productivity.

### Foundations™ Book

The authoritative resource for efficient bulk materials handling covering conveyors with a comprehensive, real-world approach. It provides valuable information to all industries and personnel at all levels.



### Conveyor Safety Book

The Global Best Practices Resource for Safer Bulk Material Handling. The Foundations™ for Conveyor Safety book is the world's first collection of worldwide best practices.



## N2® Position Indicator



The intuitive N2® Position Indicator allows for remote monitoring of the belt cleaner blade via Martin's proprietary mobile app and desktop dashboard, indicating remaining blade life, notifying when re-tensioning or replacement is required, and warning in the event that the blade is no longer in contact with the belt.

The N2® Position Indicator is capable of collecting data and providing insights for any belt cleaner utilizing a Martin® blade.

Insights gained from remote monitoring makes maintenance more efficient, takes the guesswork out of replacement blade ordering and inventorying, and reduces worker exposure to belt conveyor hazards.

The N2® Gateway receives information from up to 200 N2® Position Indicators and transmits information to the cloud for monitoring via the Martin® Smart Device Manager mobile application.



HD model



XHD model

HD model installed on a QC1+ Cleaner

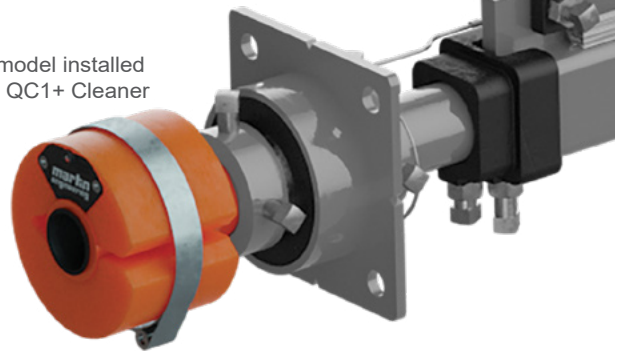

## Resources



Visit our online **Foundations™ Learning Centre** for free articles, videos, e-books, and blog posts offering a broad variety of information including selection guides, maintenance checklists, troubleshooting tips and tricks, and much more. >> [foundations.martin-eng.com/en/knowledge](https://foundations.martin-eng.com/en/knowledge)



Visit our **On-Demand Webinar Library** for dozens of free on-demand video recordings covering a wide variety of topics including belt conveyor optimization, carryback and belt cleaning, material flow, dust control, and safety and culture. >> [foundations.martin-eng.com/webinars-on-demand](https://foundations.martin-eng.com/webinars-on-demand)



Visit our website to download our **Foundations™ Books**, industry-standard textbooks for cleaner, safer, and more productive conveyor operation and maintenance, along with e-books covering a variety of specific bulk material handling and material flow topics. >> [foundations.martin-eng.com/book-options](https://foundations.martin-eng.com/book-options)

**Our partners**



**Wright Bros Industrial Services Ltd**

Red Ln, Worksop S81 8BP

+44 (0) 1909 730507

afersales@wrighteng.co.uk

Part of the Wright Group of Companies.

www.wrightgroupuk.com

*Our Partner in England and Wales*



Wright Engineering have been at the forefront of cutting edge Engineering Design, Fabrication and Installation solutions for over 30 years. Based at the headquarters in North Nottinghamshire, Wright Engineering work around the world on complex design and engineering projects.



**Plimley Trading Ltd**

Unit 1 Newbridge Ind. Estate

Newbridge

Co. Kildare

W12 A074

Ireland

+353 (0) 45 432 120

info@plimley.com

www.plimleytrading.ie

*Our Partner in Ireland*



Plimley Trading Ltd is a well established, diversified mechanical engineering firm based in Newbridge, Co. Kildare. Plimley specialise in high quality workshop fabrication complimented by site maintenance and installations and have been evolving over the past five decades working with its valued customers across multiple industry sectors with strong involvement in quarry, blacktop (asphalt), concrete, and cement plant maintenance since 1974.



## PRODUCT CATALOGUE

### Martin Engineering Ltd.

The Tangent Hub, Unit 33,  
Weighbridge Rd, Shirebrook,  
Mansfield, NG20 8RX, UK

+44 (0)1159 464746

[info@martin-eng.co.uk](mailto:info@martin-eng.co.uk)

[www.martin-eng.co.uk](http://www.martin-eng.co.uk)

L4203UK-P-06/26

Patents and patents pending. ® Registered  
trademark of Martin Engineering Company  
in the US and other select locations.  
© 2026 Martin Engineering Company.

