

Martin® External Wear Liner

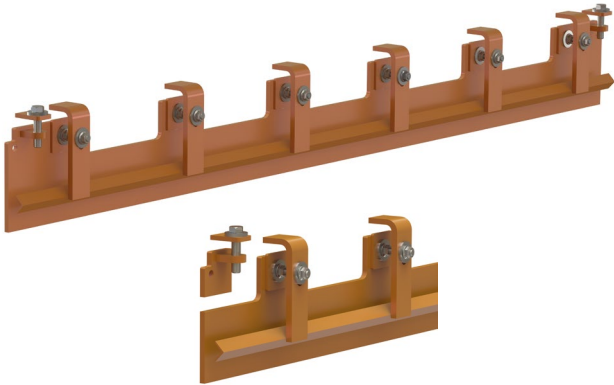

Installed outside conveyor transfer point skirtboards, **Martin® External Wear Liner** is an economical upgrade that improves skirtboard sealing and prevents spillage. Wear liner can typically be installed without requiring work inside chute or interfering with existing chute supports.

Martin® External Wear Liner can easily be installed on existing studs in applications already using Martin® ApronSeal™ skirting and clamps.

BENEFITS

Improves Sealing

Keep the burden of cargo away from sealing system.

Simple Installation

Wear liner plates mount to the outside of existing transfer point skirtboard, without interfering with existing supports.

Easy Adjustment

Jack screws provide precise adjustment of wear liner to reduce spillage.

Suits a variety of cargo and conditions

The wear areas are available in 10mm thick wear resistant steel (HARDOX 500 or comparable) or stainless steel (1.4571). Fits conveyors with trough angles from flat to 35°. Standard lengths are 500 mm, 1.000 mm and 2.000 mm.

Compatibility of side sealings

The external Wear Liner can be combined with Martin® ApronSeal™ Double Skirting PN 100873+E, Martin® ApronSeal™ Double Skirting HD PN 100861+E, Martin® ApronSeal™ Single Skirting PN 100724+E and Martin® ApronSeal™ Single Skirting HD PN 100723+E.

Improves Maintenance

Replacing worn external wear liner requires minimal welding and no chute entry.

| Item | Part Number |
|---------------------------------|--------------|
| External Wear Liner | 41778-XXXXXX |
| External Wear Liner Adapter Kit | 41790-XXXX |

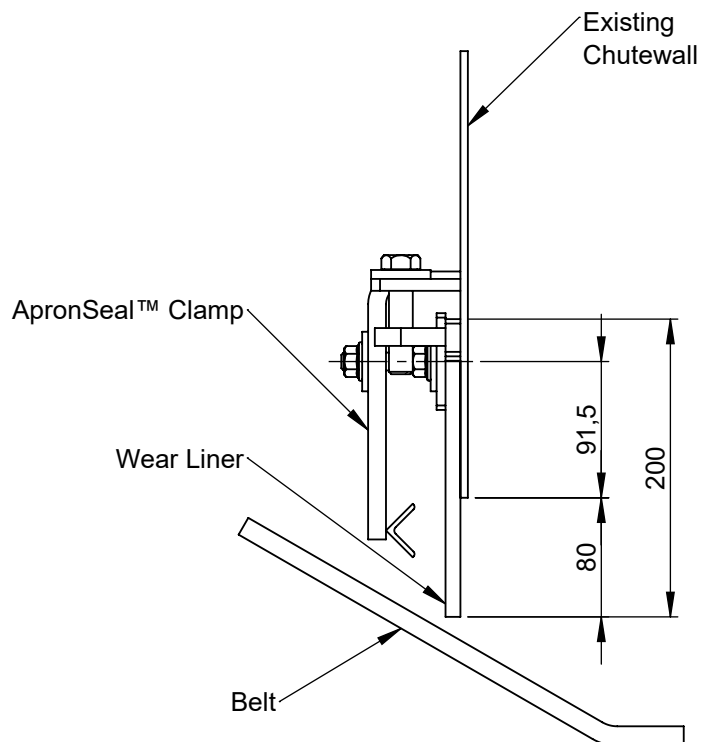

SPECIFICATIONS

| Temperature range C° | Throughing angle | Reversing |
|-------------------------|---------------------|-----------|
| -30 – 150 °C | 0° - 35° | yes |

Martin® External Wear Liner

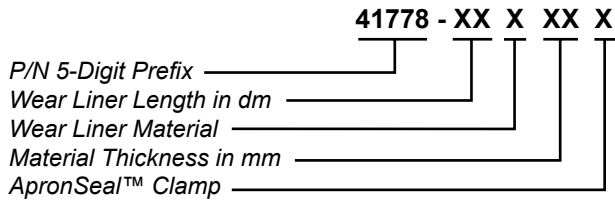

WEAR LINER LENGTH

- 05:** 500 mm
- 10:** 1000 mm
- 20:** 2000 mm

WEAR LINER MATERIAL

- 5:** Hardox 500 painted (RAL 2004)
- S:** Stainless Steel (1.4571)

MATERIAL THICKNESS

- 10:** 10 mm

APRONSEAL™ CLAMP

- S:** with Standard Clamp
- 0:** without clamp

Martin® External Wear Liner Adapter Kit

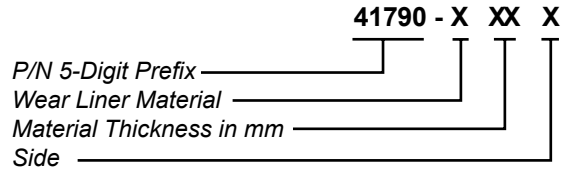

WEAR LINER MATERIAL

- 5:** Hardox 500 painted (RAL 2004)
- S:** Stainless Steel (1.4571)

MATERIAL THICKNESS

- 10:** 10 mm

SIDE

- L:** Left
- R:** Right
- 0:** not welded



Martin Engineering Ltd

The Tangent Hub, Unit 33,
Weighbridge Rd, Shirebrook,
Mansfield, NG20 8RX, UK
Ph.: 0044 (0)115 946 4746
info@martin-eng.co.uk | www.martin-eng.co.uk