

Martin® DT2S Reversing Cleaner

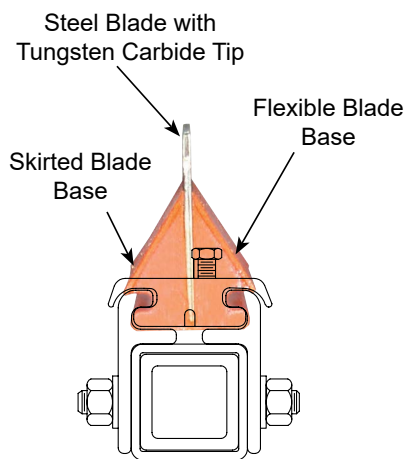

Combining the best features of two successful Martin Engineering Secondary Cleaners, the **Martin® DT2S Reversing Cleaner** features a split-track blade cartridge that slides in and out on a stainless steel mandrel. This unique engineering makes for a fast and easy service procedure to reduce conveyor downtime.



BENEFITS

- Removes Carryback, Saves Cleanup**
 Effective belt cleaning reduces plant clean-up chores, and prolongs life of conveying equipment.
- 5-Minute Blade Change**
 Blades slide into split-frame cartridge; cartridge slides into cleaning position on stainless steel mandrel.
- Minimizes Service Time**
 Slide-in/slide-out blade cartridge allows quick and easy blade service that minimizes conveyor downtime. Even when the cleaner is encrusted with material, one-half of the split frame can be removed to allow blade change. With on-site safety approvals, blades can be changed while the belt runs.
- Installs in Small Places**
 Lean profile minimizes space requirements, allows installation in narrow spaces.
- Suitable for Reversing Belts**
 Can be installed on conveyors that roll back or run in two directions.

SPECIFICATIONS

Belt Widths (mm)	Operating Temperature* (°C)	Maximum Belt Speed (m/sec.)	Reversing operation
500 - 3000	-40 - +150	4,6	Yes

*Depending on polyurethane type

NOMENCLATURE DT2S-XX X XXXX X X

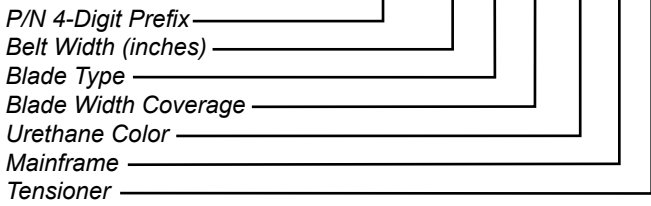

Blade Type

- 0:** No Blade
- R:** Tungsten Carbide Insert with Stainless Steel Holder
- T:** Tungsten Carbide Blade
- S:** Stainless Steel Reversing Blade
- U:** Urethane Blade
- M:** Mild Steel Reversing Blade

Cleaning width in inches

- 00:** No Blades

PU type (blade)

- 00 =** No Blades
- OR =** Orange
- BR =** Brown
- GR =** Green

Mainframe options

- P =** Painted Steel
- S =** Stainless Steel
- E =** Extended Painted Steel

Tensioner options

- 0 =** No Tensioner
- S =** Painted Spring Tensioner

Spring Tensioners

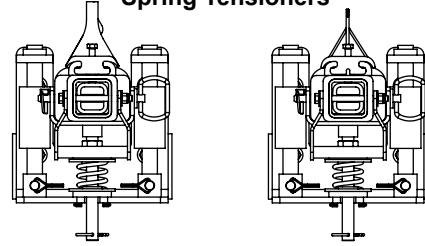

Martin® DT2S REPLACEMENT BLADES

Martin® DT2S Reversing Blade	P/N
Tungsten Carbide	31104 - T
Urethane	31104 - U
Stainless Steel	31104 - S
Mild Steel	31104 - M
Tungsten Carbide with Stainless Steel Holder	31104 - TCS

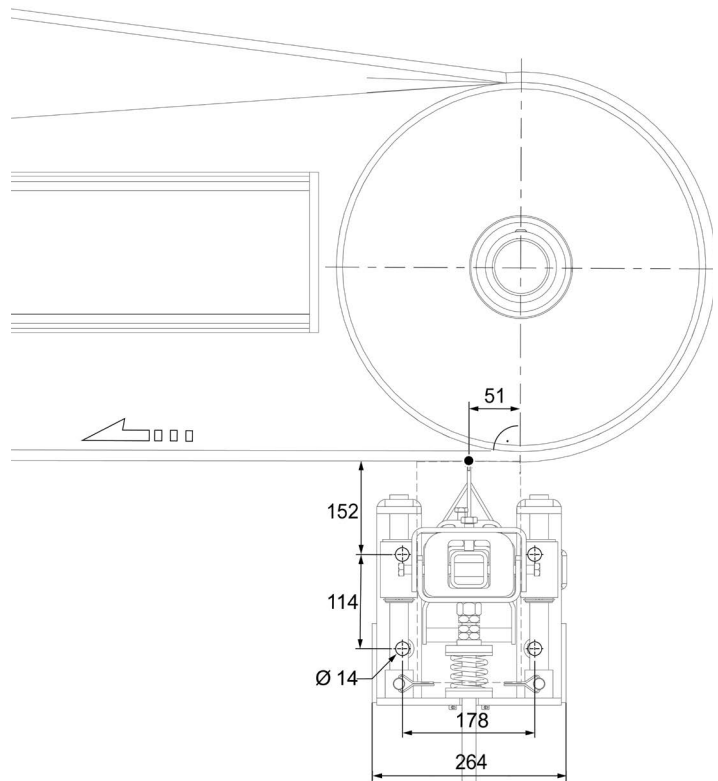

DIMENSIONS – in. (mm)

Belt width in. (mm)	Blade Coverage in. (mm)	No. of Blades	Mainframe length standard (mm)	Mainframe length extended (mm)
18 (500)	12 (305)	2	1257	1867
	18 (457)	3		
24 (650)	18 (457)	3	1410	2019
	24 (610)	4		
30 (800)	24 (610)	4	1562	2172
	30 (762)	5		
36 (1000)	30 (762)	5	1715	2324
	36 (914)	6		
42 (1200)	36 (914)	6	1867	2477
	42 (1067)	7		
48 (1400)	42 (1067)	7	2019	2629
	48 (1219)	8		
54 (1600)	48 (1219)	8	2172	2781
	54 (1372)	9		
60 (1800)	54 (1372)	9	2324	2934
	60 (1524)	10		
66 (1900)	60 (1524)	10	2477	3086
	66 (1676)	11		
72 (2000)	66 (1676)	11	2629	3239
	72 (1829)	12		
84 (2200)	78 (1981)	13	2334	3543
	84 (2134)	14		
96 (2400)	90 (2286)	15	3239	3848
	96 (2438)	16		
108 (2800)	102 (2591)	17	3543	N/A
	108 (2743)	18		
120 (3000)	114 (2896)	19	3848	N/A



Martin Engineering Ltd
 The Tangent Hub, Unit 33,
 Weighbridge Rd, Shirebrook,
 Mansfield, NG20 8RX, UK
 Ph.: 0044 (0)115 946 4746
 info@martin-eng.co.uk | www.martin-eng.co.uk