

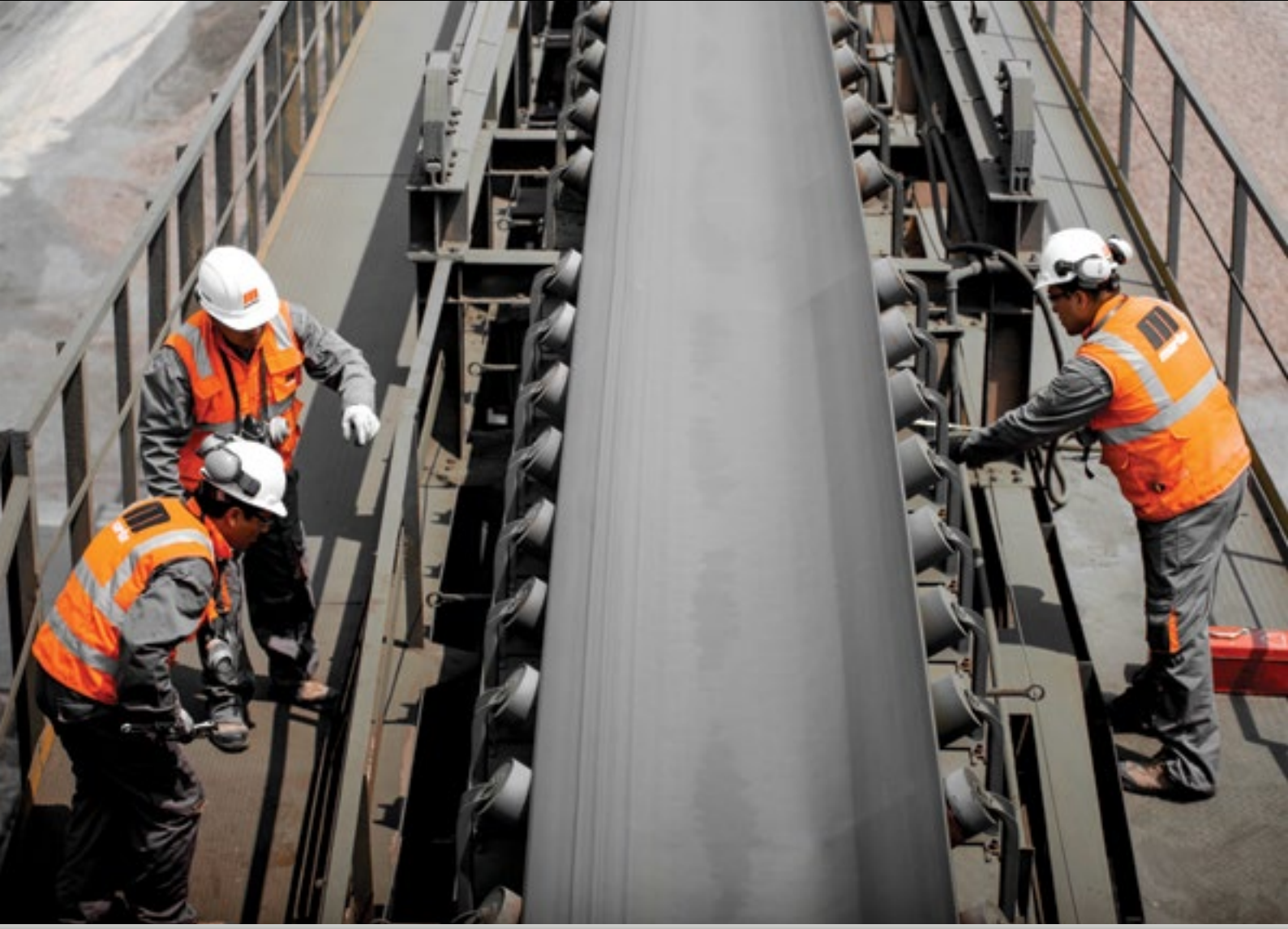

CONVEYOR PRODUCTS

CONTAIN • CONTROL • ADVANCE

L4119 UK



Problem Solved™
GUARANTEED!

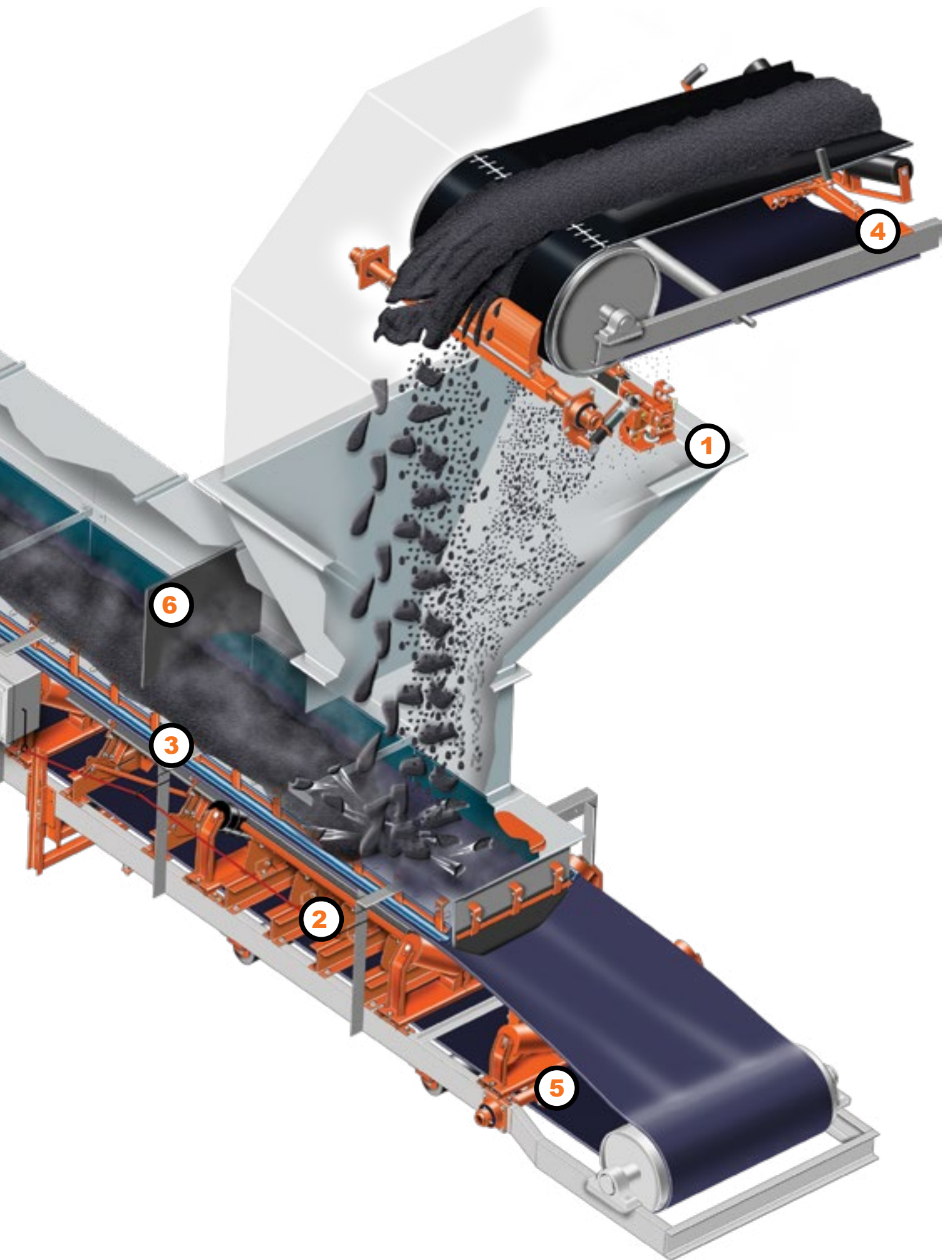

TRANSFER POINT SOLUTIONS

PERSONALISED TO MATCH YOUR CONVEYOR, YOUR MATERIAL AND YOUR PROCESS REQUIREMENTS.

(1) BELT CLEANING

Belt cleaners ensure minimised carryback, reduced unscheduled downtime and lower maintenance costs, as well as extending equipment life.

(2) BELT SUPPORT

For an effective, minimum-spillage transfer point, it is essential that the belt's line of travel is stabilised with proper belt support in the load zone.

(3) SEALING SYSTEM

A crucial requirement in any transfer point designed for reduced spillage and high efficiency is an effective sealing system at the edge of the belt.

(4) BELT TRACKING

Belt tracking must be controlled before spillage can be eliminated.

(5) TAIL PULLEY PROTECTION

Pulley protection ploughs are installed to remove lumps and stray objects before they can damage the pulley or belt.

(6) DUST MANAGEMENT

Airborne dust is a common problem in bulk-materials handling operations. When both material spillage and airborne dust are controlled, the operation is cleaner, safer and more productive.

Martin Engineering offers a wide range of products and technologies, including those mentioned above, that reduce dust and spillage, boost flow, extend component life and reduce downtime, resulting in improved working environments and increased profitability. Please contact Martin for more details.

PRIMARY BELT CLEANERS

1

MARTIN® PRIMARY CLEANERS

As the first stage in a multiple cleaner system, the primary cleaner removes the majority of material stuck to the belt, leaving only a thin layer of sticky fines.

Primary cleaners are generally tensioned at low pressure against the belt. Low blade-to-belt pressure allows the primary cleaner to be positioned at a peeling angle against the belt. Using higher pressure at this angle could damage the belt, splice or cleaner itself.

Primary cleaners are typically installed on the face of the head pulley, just below the material trajectory. The cleaner should be constructed to avoid material build-up and installed so it is out of the way of the material stream.

SELECTION GUIDE

Required Data

- Belt width
- Head pulley diameter
- Belt speed
- Material characteristics
- Application temperature

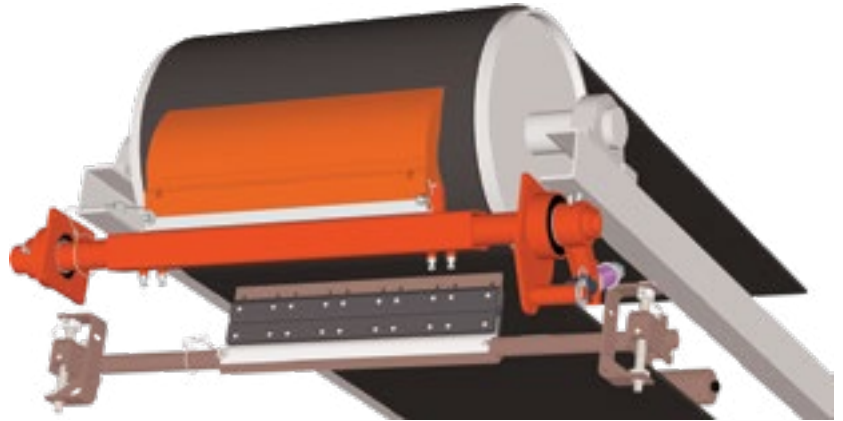

Selection Process

1. Use your conveyor's specifications for **belt width** and **pulley diameter** to select a primary cleaner in the Primary Cleaner Sizing Chart on the next page.
2. Check your selection against the recommended **maximum belt speeds** in the Primary Cleaner Sizing Chart on the next page.
3. Use **material characteristics** and **application temperature** to identify the appropriate urethane blade in the chart on page 8.

PRIMARY BELT CLEANERS

PRIMARY CLEANER SIZING CHART

Belt Width mm	Head Pulley Diameter — mm						
	180-250	300-400	450-560	600-760	810-970	1010-1170	1220+
300-400	1	2	N/A	N/A	N/A	N/A	N/A
400-500	1	2	3	4	N/A	N/A	N/A
500-650	1	2	3	4	N/A	N/A	N/A
650-800	1	2	3	4	N/A	N/A	N/A
800-1000	1	2	3	4	N/A	N/A	N/A
1000-1200	2	2	3	4	5	N/A	N/A
1200-1400	2	2	3	4	5	5	6
1400-1600	2	2	3	4	5	5	6
1600-1800	2	2	3	4	5	5	6
1800-2000	2	2	3	4	5	5	6
2000-2200	N/A	3	3	4	5	5	6
2200-2400	N/A	3	3	4	5	5	6
2600-2800	N/A	N/A	N/A	N/A	5	5	6
2800-3000	N/A	N/A	N/A	N/A	5	5	6

1 = Compact Cleaner

2 = PV Cleaner

3 = QC1™ Cleaner HD

4 = QC1™ Cleaner XHD

5 = SHD 600 Series Cleaner

6 = SHD 1200 Series Cleaner

Please note: Stainless steel mainframes and tensioners are available for corrosive environments.

PRIMARY CLEANER SCALE & BELT SPEEDS

Maximum Belt Speed by Categories: m/sec

Blade Dimensions given in mm

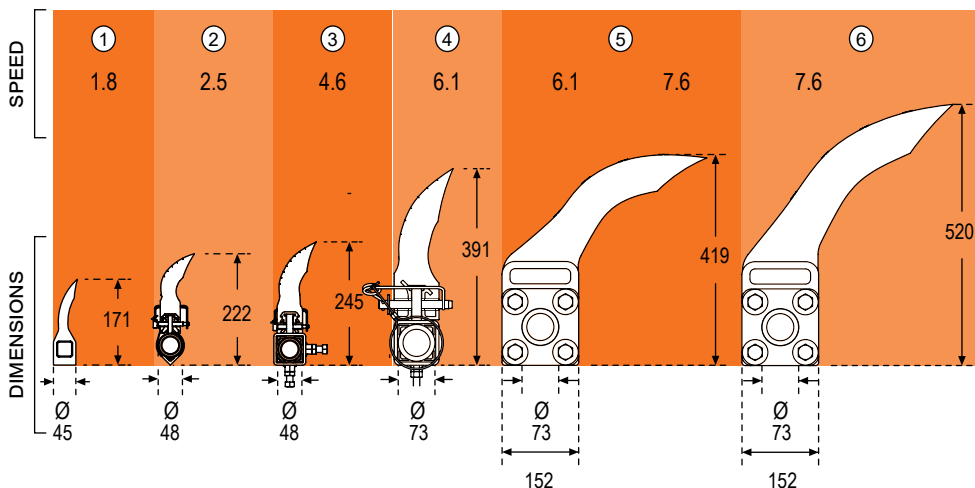

In instances of conflict between size and speed, choose the larger size.



PRIMARY BELT CLEANERS

1



Martin® PV Cleaner ②

MARTIN® PV CLEANER

- Engineered to simplify blade service and reduce costs, the Martin® PV Cleaner provides quick and easy 'one-pin, no-tool' blade replacement.
- Aggressive angle of attack to the belt increases cleaning efficiency.
- 'One-pin' attachment means fast and easy maintenance, less downtime for blade service; no more fighting rusty bolts and no more lost fasteners



Martin® QC1™ Cleaner HD ③

MARTIN® QC1™ HEAVY DUTY CLEANER & MARTIN® QC1™ MT CLEANER

- Reduced maintenance effort. Fast replacement of the blade – no tools required, simply remove and reinstall a single lock pin.
- Even cleaning results. The blade with patented 'CARP' (Constant-Angle/Constant-Area Radial Pressure) design and the tensioners used provide efficient cleaning during the entire wear life of the blade, particularly with high belt speeds and/or mechanical joints.
- Robust and flexible design. The robust mainframe is reinforced with welded on sheet material. The aluminium seating of the blade ensures safe fixing to the mainframe.



Martin® QC1™ MT Blade

The Martin® QC1™ Cleaner with Metal Tipped Blade provides maximum durability and performance across a wide range of duties and applications. This sturdy cleaner features a tungsten carbide tip blade that lasts 2 to 3 times longer than conventional urethane blades.

PRIMARY BELT CLEANERS

MARTIN® QC1™ XHD CLEANER

Engineered to preserve the cleaning edge from high belts speeds and multiple splices.

Patented 'CARP' (Constant-Angle/Constant-Area Radial Pressure) blade design maintains cleaning performance through all stages of blade life.

An aluminum extrusion in the belt cleaner blade base holds the cleaner snugly to the backbone.



Martin® QC1™ Cleaner XHD ⑥

MARTIN® SHD 600 & 1200 SERIES CLEANERS

Structural steel means no more bent mainframes, even with high tonnages and large lumps.

Massive urethane blades provide up to 305 mm of wear life.

Martin® SHD Cleaner and tensioner are designed together for effective cleaning and reduced service requirements.

Patented 'CARP' (Constant-Angle/Constant-Area Radial Pressure) blade design maintains cleaning performance through all stages of blade life.

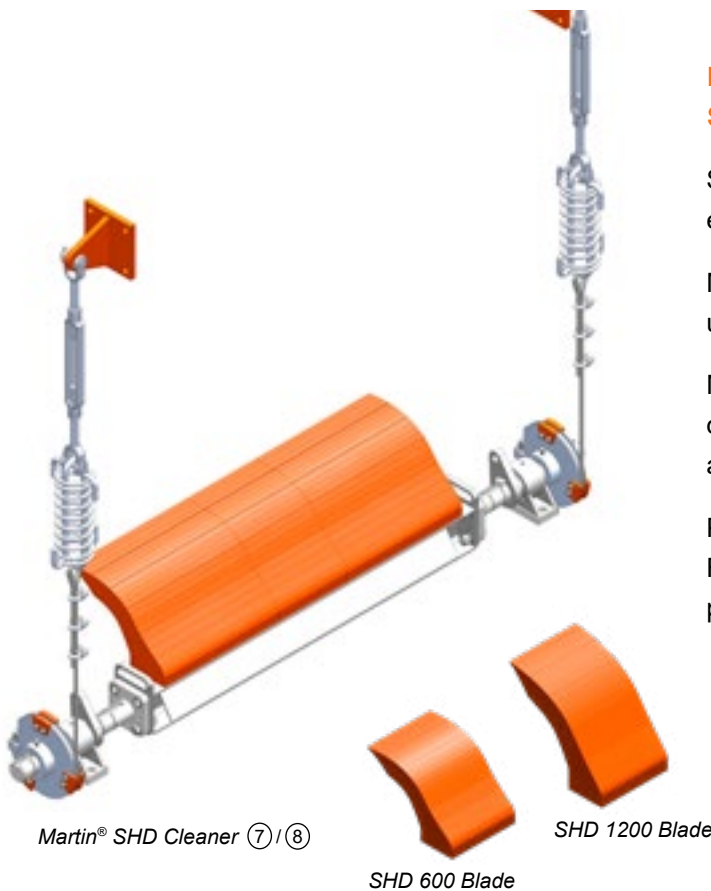

Martin® SHD Cleaner ⑦/⑧

SHD 1200 Blade

SHD 600 Blade

PRIMARY BELT CLEANERS

1

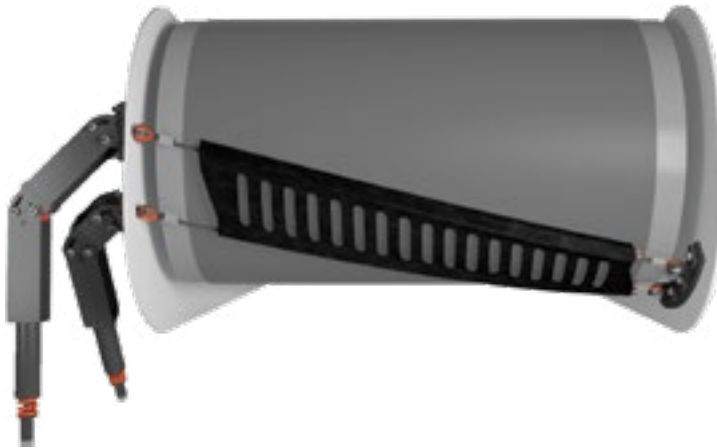

MARTIN® CLEANSCAPE® CLEANER

The CleanScape® Belt Cleaning System introduces a revolutionary innovation in belt cleaning technology.

- Efficient & effective performance
- Lower maintenance as compared to traditional cleaners
- Safe for belts
- Reduces operating costs

2



CleanScape® Cleaner

CleanScape® is installed diagonally across the discharge pulley and forms a three-dimensional curve.

The cleaner incorporates a matrix of carbide tips and is tensioned across the belt in a specified angle. Despite an extremely low contact pressure between belt and cleaner, any stuck material is removed very efficiently.

Dimensions	∅ Pulley dia. (mm)	Belt width (mm)
CSP S	300 - 550	400 - 1000
CSP M	550 - 900	500 - 1800
CSP L	900 - 1250	800 - 2400
CSP H	800 - 2000	1000 - 3000

BLADES

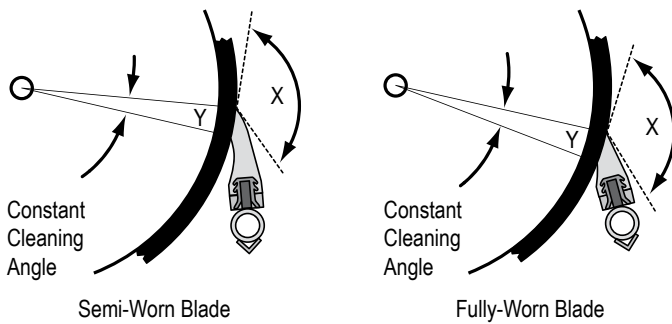

Martin belt cleaner blades come in a large array of shapes, sizes and materials to most effectively remove any type of material carryback while protecting the belt and its splices.

Both metal and non-metal blades are available, including urethane, rubber, ceramic, mild and stainless steels and tungsten carbide.

Martin® CARP Blade Design

Patented Constant-Angle/Constant-Area Radial Pressure blade design ensures uniform contact throughout the life of the blade. This allows the tensioner to maintain proper tension ensuring maximum cleaning efficiency at all times.

Martin® CARP Blades are protected by U.S. Patent No. 4,917,231.

SELECTION GUIDE

Color	Application Description	Typical Materials	Temperature Range
Orange (blank or OR)	Standard Martin® Urethane is suitable for most applications, including abrasive conditions and exposure to solvents or oil.	Bauxite, coke, coal, refuse, steel/ore, etc.	-30° to 70°C
Brown (BR)	Chemical-Resistant Urethane provides improved resistance to chemicals and reduced water absorption in high-moisture environments.	Limestone	-40° to 70°C
Green (GR)	High-Temperature Urethane withstands exposure to intermittent temperatures of up to 177°C.	Clinker	-40° to 150°C
Clear (CL)	Low-Rigidity Urethane is ideal for dry products such as sand and gravel.	Gravel, dry sand	-40° to 70°C
Navy Blue (NB)	Low-Adhesion Urethane is ideal for sticky or tacky materials.	Cement, glass, wood chips	-30° to 70°C



SECONDARY BELT CLEANERS

1

MARTIN® SECONDARY CLEANERS

Installed at the point where the belt is leaving the discharge pulley, a secondary cleaner removes residual fines that remain on the belt past the primary cleaner.

Its location is typically close enough to the material trajectory that the residual material will return to the main stream.

Additional tertiary cleaners can be installed to provide final cleaning. These cleaners can be the same model as the secondary cleaner, or a different design to allow efficient cleaning and maintenance within the available space.

As these cleaners are typically installed away from the pulley, they should be placed at or near a point where the belt is against a roller. This firm support prevents the cleaning pressure from distorting the belt line and reducing cleaning efficiency.

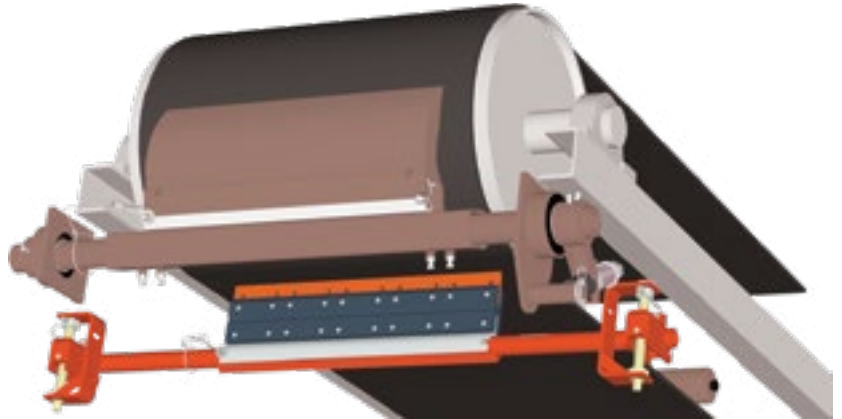

REMARKS

- Check your conveyor's belt speed against the specifications listed for the secondary cleaners in the table below.
- If your belt features multiple mechanical splices, or a mechanical splice in poor condition, avoid using tungsten carbide blades as rapid wear or damage to both blade and splice may result.

APPLICATION SPECIFICATIONS

Belt Cleaner	Max Belt Speed m/sec	Handles Reversing Belts & Rollback	Available Blade Materials		
			Stainless Steel	Tungsten Carbide	Urethane
SQC2 / SQC2 Mini Cleaner	5.1	X	X	X	X
CleanScrape® Secondary Cleaner	5/3*	X	X	X	

* 5 m/s for vulcanized splices and 3 m/s for mechanical splices

Please note: Stainless steel mainframes and tensioners are available for corrosive environments.



SECONDARY BELT CLEANERS



Martin® SQC2™ Cleaner

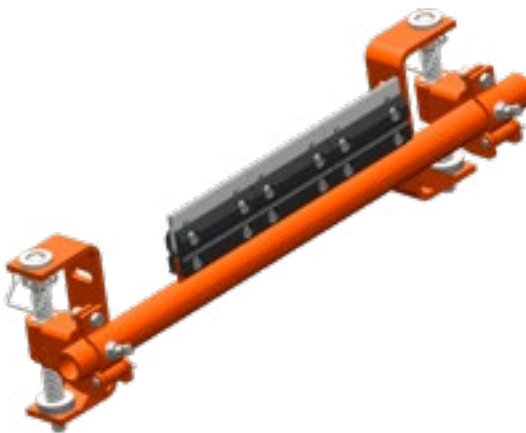

Martin® SQC2™ Mini Cleaner

MARTIN® SQC2™ & SQC2™ MINI CLEANER

Individually-cushioned tungsten carbide blades provide effective cleaning without risk to belt, splice or blade. Rubber blade buffers cushion the impact of each blade individually, maintaining consistent cleaning pressure. Blade cartridge allows quick and easy removal of all blade segments for rapid return to service. Compact design allows installation in tight spaces while narrow profile resists material build-up.

- Acid-resistant tips available.
- Blade buffers available in molded rubber and flame-retardant rubber.
- “SAF” Soft Touch Set and forget tips available

SECONDARY BELT CLEANERS

1



Cleanscrape® Secondary Cleaner

CLEANSRAPE® SECONDARY CLEANER

The CleanScrape® Secondary Cleaner is a secondary cleaner available in stainless steel or partly mild steel assembly featuring independent 6-inch wide blades with carbide tips. Each blade tip is supported on spring loaded arms at both ends. The load springs allow independent blade rotation back and forward as well as up and down. This “range-of-motion” provides equal load pressure across each blade, absorbs obstructions, and conforms to ever-changing belt undulations.

- Optimum cleaning results
- “Free Flow” design allows for material to pass through arms
- The Mainframe design compensates for belt wear in the center
- Low Blade-to-Belt pressure
- Simple installation inside or outside of chute
- Removed material returns to main flow
- Requires less tensioning over lifespan
- Easy cartridge removal
- Easy adjustment of cleaning pressure

SPECIALTY BELT CLEANERS



Martin® Washbox™ Cleaning System

MARTIN® WASHBOX™ CLEANING SYSTEM

Installed as a secondary cleaner along the conveyor's return run, the Martin® Washbox™ Cleaning System provides the ultimate in belt cleaning technology. Each Martin® Washbox™ Cleaning System can be custom-engineered to match your cleaning requirements.

Martin® Washbox™ Spray Wash Systems are designed for use in applications where the conveyor belt must be very clean. As the belt enters the Washbox™ a set of return idlers stabilise the belt. A spray bar uniformly sprays the belt with water.

The dual secondary belt cleaner removes most of the material from the belt. The remaining material is removed by the third secondary belt cleaner.

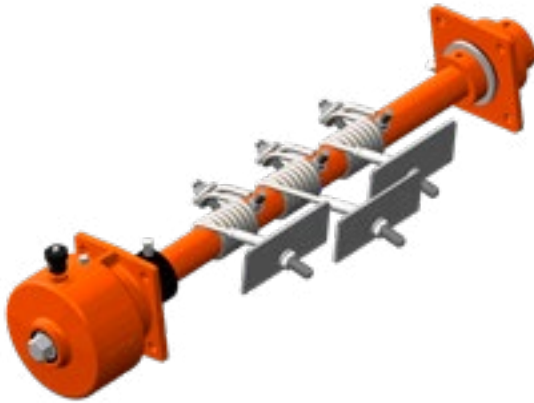

Martin® High Temperature Cleaner

MARTIN® HIGH TEMPERATURE CLEANER

All-steel construction allows the Martin® High Temperature Cleaner to withstand temperatures up to 315°C.

Overlapping stainless steel or tungsten carbide blades on coil spring arms provide effective cleaning.

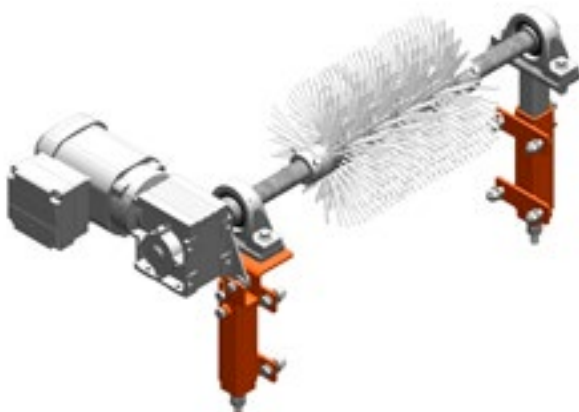

Martin® Brush Cleaner

MARTIN® BRUSH CLEANER

The MARTIN® brush cleaner, either on its own or in combination with other cleaners, removes material residues from conveyor belts and therefore prevents the formation of dust and accumulations of material along the belt conveyor system.

TENSIONERS

1

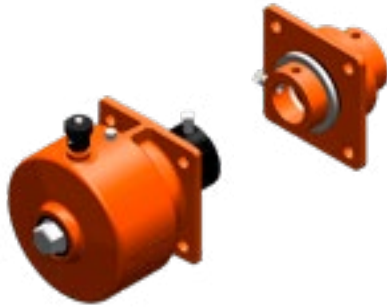

Martin® Twist™ Tensioner

MARTIN® TWIST™ TENSIONER

The Martin® Twist™ Tensioner can be used on either primary cleaners or secondary cleaners.

Rubber element maintains cleaning pressure with minimal belt cleaner re-tensioning required.

Tensioner allows mechanical splices to pass without damage.

If blades pull through, the tensioner's coupling rolls over, releasing pressure and reducing the risk of harm to personnel or equipment.

Light aluminum housing and fully enclosed design keeps the tensioner mechanism clean.

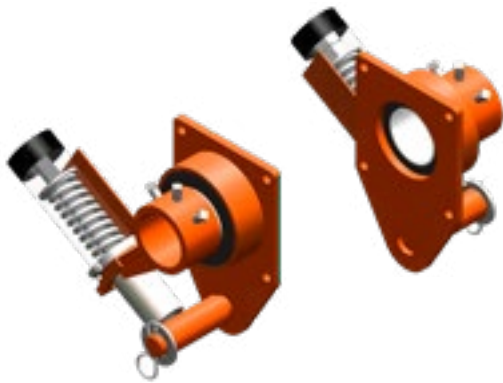

Martin® Spring Tensioner XHD

MARTIN® XHD SPRING TENSIONERS

XHD spring tensioners provide effective cleaning pressure while cushioning splice shock to prevent damage and proficient tensioning for extra heavy-duty belt cleaners while standing up to tough conditions.

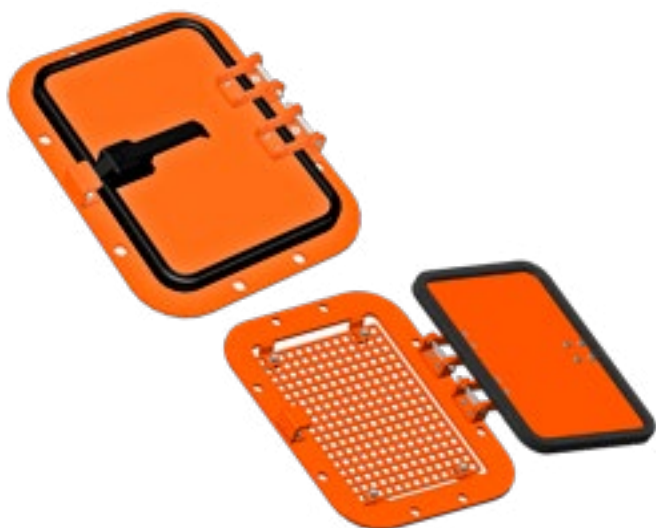

Martin® Inspection Doors

MARTIN® INSPECTION DOOR

Available in mild steel or stainless steel, Martin® Inspection Doors provide quick and easy access to belt cleaners and other components inside chutes and enclosures for inspection or service.

The inspection doors can be used in temperatures from -30°C up to +80°C. Various sizes are available depending on the needs.

BELT SUPPORT

MARTIN® BELT SUPPORT SOLUTIONS

Like the construction of a building, the construction of an efficient conveyor system begins with a solid foundation. In a building it's the footings. In a conveyor system it's the belt line.

A stable belt will absorb loading-zone impact, eliminate sag and prevent material entrapment. For an effective, minimum-spillage transfer point, the belt's line of travel must be stabilised with proper belt support in the load zone.

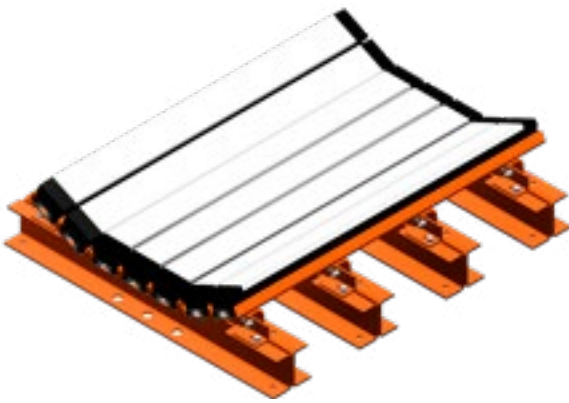

Martin® Impact Cradle

MARTIN® IMPACT CRADLES

Installed under a belt conveyor loading zone, Martin® Impact Cradles absorb the force of falling material to prevent damage to the belt and structure. The impact cradles stabilise the belt line and prevent material escape

- Rugged, durable bars are composed of a top layer of low friction UHMW and a lower layer of energy-absorbing foam rubber.
- Each impact bar is reinforced with a bed of steel channels.
- Wings adjust to match any standard trough angle for easy installation.



Martin® Trac-Mount™ design incorporates impact bars mounted on sliding sleeves to reduce maintenance.

BELT SUPPORT

SYSTEM SELECTION GUIDE

Determine weight of largest lump and drop height.

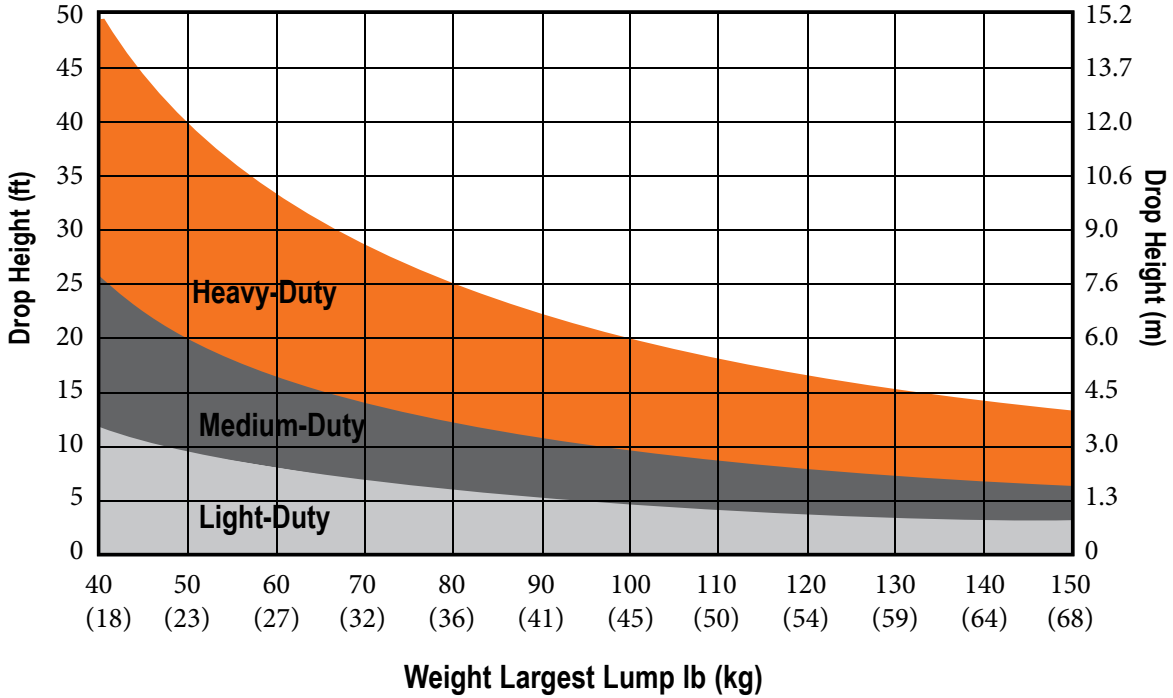

Code Rating		L	M	H
		Light-Duty	Medium-Duty	Heavy-Duty
Impact Force	(lbf.)	< 8,500	< 12,000	< 17,000
	(kN)	< 35	< 53	< 76
W x H (ref.)	lb.-ft.	< 200	< 1000	< 2000
	kg-m	< 28	< 138	< 277



BELT SUPPORT

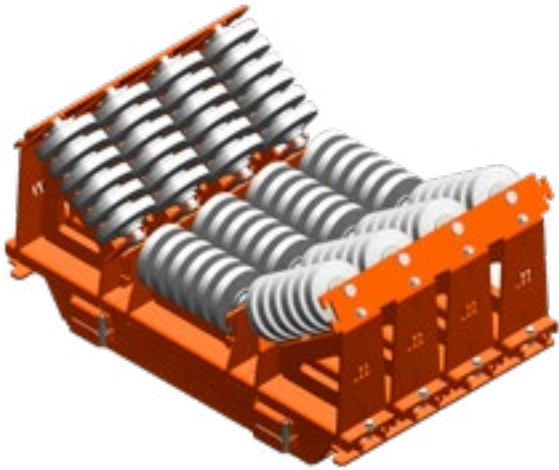

Martin® High-Speed Impact Cradle

MARTIN® HIGH-SPEED IMPACT CRADLE

Designed and engineered for high speed / high tonnage belts, Martin® High Speed Impact Cradles provide belt support at transfer points where belt speeds exceed the operating limits of ordinary impact bar belt support cradles.

MULTIPLE-CRADLE SYSTEMS

It is often appropriate to install combination systems, incorporating both impact-absorbing cradles and seal-support cradles. As many impact cradles as necessary should be installed to support the belt to the end of the impact zone. Side-seal support cradles then complete the system over the distance required to stabilise the load in the skirted area.

These systems provide an efficient way to combine optimum belt support with maximum cost-efficiency in system construction and power consumption.

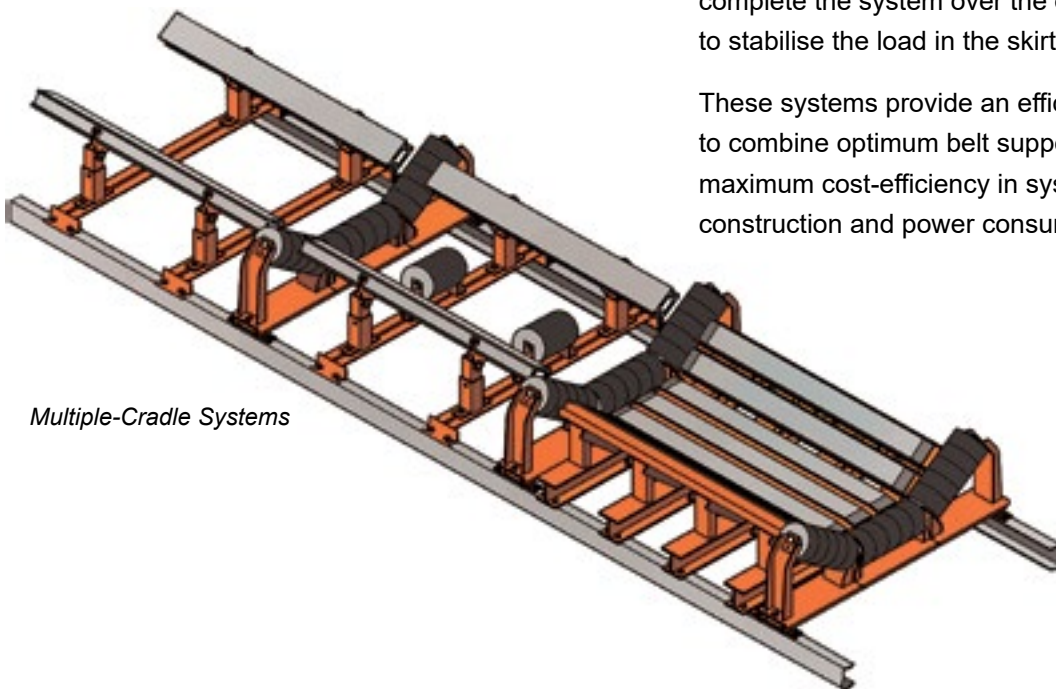

Multiple-Cradle Systems

BELT SUPPORT



Martin® Slider Cradle

MARTIN® SLIDER CRADLE

Installed under the skirtboard of a transfer point, Martin® Slider Cradles support the edges of the belt to eliminate sag. These cradles prevent transfer point spillage by stabilizing the belt's path and allow the effective sealing of the belt edge. Cradles are available with high-performance UHMW or stainless steel bars to match application requirements.

- Martin Engineering recommends the installation of a Martin® Trac-Mount™ Idler set before and after each cradle.
- Slider Cradles support belt edges, allowing for the effective seal of a stable belt path.
- Slider Cradles protect the belt by eliminating pinch points where trapped material can gouge the belt.
- Unique 'box' design of UHMW bar allows use of both top and bottom surface for double the life.
- To compensate for wear, adjust cradle easily with hand tools – a simple bar change without system disassembly.
- Slider Cradles adjust to fit any trough angle.

Options available to meet application requirements

SEALING SYSTEMS

The goal of any sealing system is to keep dust and fines from escaping. No sealing system can withstand prolonged pressure from the material load. An effective sealing system incorporates multiple components to not only prevent spillage, but also protect the system from material-load forces.



Martin® Double Skirting

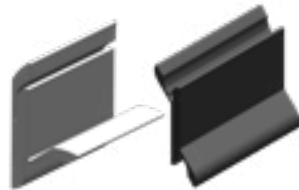

MARTIN® APRONSEAL™ DOUBLE SKIRTING

The Martin® ApronSeal™ Double Skirting is a primary and secondary sealing strip in a dual-sided single elastomer.

- Provides effective sealing on higher speed belts.
- Offers dual life—can be flipped over and used.
- 70 Shore D durometer rubber composite offers good chemical resistance and low-abrasion index characteristics.
- Available in continuous lengths up to 90 m.
- Applicable on 0° - 45° troughing angles.



Martin® External Wear Liner



MARTIN® EXTERNAL WEAR LINER RETROFIT

Installed outside conveyor transfer point skirtboards, Martin® External Wear Liner Retrofit Kit is an economical upgrade that improves skirtboard sealing and prevents spillage. It can be used on new installations or to upgrade systems utilizing Martin® ApronSeal™. Wearliners can typically be installed without requiring work inside the chute or interfering with existing chute supports.

SEALING SYSTEMS



Martin® Self Adjusting Skirting

MARTIN® SELF ADJUSTING SKIRTING

Self-adjusting skirting system rides the belt to create an effective seal automatically. Requires only 152 mm clearance and only 38 mm free belt area for sealing. Also available in Urethane XHD profile.

Sealing Systems Application Selection Guide

		Belt Trough Angle												
		Self-Adjusting Skirting				Standard ApronSeal™				Heavy Duty ApronSeal™				
Free Belt Area (mm)		0	20	35	45	0	20	35	45	0	20	35	45	
	102		Grey	Grey	Grey	Orange	Orange	Orange	Orange	Orange	Grey	Grey	Grey	Grey
	95		Grey	Grey	Grey	Orange	Orange	Orange	Orange	Orange	Grey	Grey	Grey	Grey
	89		Grey	Grey	Grey	Orange	Orange	Orange	Orange	Orange	Grey	Grey	Grey	White
	83		Grey	Grey	Grey	Orange	Orange	Orange	Orange	Orange	Grey	White	White	White
	76		Grey	Grey	Grey	Orange	Orange	Orange	White	White	Grey	White	White	White
	63		Grey	Grey	Grey	Orange	White	White	White	White	White	White	White	White
	51		Grey	Grey	Grey	Orange	White	White	White	White	White	White	White	White



BELT TRACKING

Martin Engineering's belt alignment products provide immediate, continuous precision adjustment that keeps conveyor belts perfectly tracked, even withstanding the stress caused by wider, thicker belts carrying heavier loads at high speeds.

Martin® belt tracking products prevent edge damage, extend belt life, reduce spillage and minimize wear and tear on equipment.



Martin® Tracker Upper Unit



Martin® Tracker Lower Unit

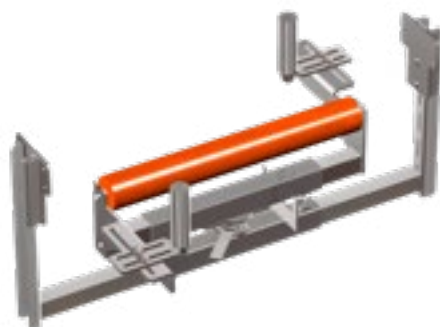

Martin® Tracker Reversing

Before spillage can be eliminated, belt tracking must be corrected. Keeping a belt running in alignment also reduces belt edge damage and maintenance expenses. With proper belt training devices, mistracking can be controlled or even eliminated.

MARTIN® TRACKER™

Provides immediate, powerful and continuous steering to correct a belt's path, preventing spillage, equipment damage and the need for repairs. Systems for offset idlers are available. Four duty ratings available to meet material handling needs.

MARTIN® TRACKER™ REVERSING

The Martin® Tracker™ Reversing provides immediate, continuous, precision adjustment of hard-to-track reversing conveyors. It effectively centres the belt regardless of the direction of travel. The Tracker™ reduces edge damage, prevents spillage and extends belt life

BELT TRACKING

SELECTION GUIDE

The different Martin® Tracker™ belt tracking systems are selected according to belt width and belt speed.

Design		Mini	Basic	Heavy-Duty	Monster		
Belt width (mm)	Part no.	41142-					
		0405XXMI	0609XXBA	1013XXBA	1013XXHD	1417XXHD	1417XXMO
400 - 500							
500 - 1000							
1000 - 1400							
1400 - 1800							
1800 - 2200							
Belt speed		<= 1.5 m/s	<= 3.5 m/s	<= 4.0 m/s	<= 5.0 m/s		



Martin® Roller Tracker

MARTIN® ROLLER TRACKER

- Superior bearings used for superior quality
- Polyurethane lagging improves durability
- Suitable for reversing applications
- Maximum belt speed 5 m/sec.

TAIL PULLEY PROTECTION

As a conveyor belt returns from the head pulley to the loading zone, it passes around the tail pulley. Occasionally, the inner side of the returning belt will carry unwanted material into the tail pulley and cause permanent damage. To guard against this possibility, tail pulley protection ploughs should be installed.



Martin® Torsion VPlow Plus

MARTIN® TORSION VFLOW PLUS

The Martin® Torsion VPlow is mounted with a unique suspension that allows it to rise and fall with fluctuations in belt tension and travel. This makes it self-adjusting for effective cleaning in all stages of blade wear. Can be used on belts with belt speeds up to 4,6 m/sec.



Martin® VPlow Modular

MARTIN® VFLOW MODULAR

The Martin® VPlow Modular is an economical solution for tail protection in medium- to heavy-duty applications. Can be used on belts with belt speeds up to 900 fpm (4.6 m/sec).

Easily replaceable blade provides 2 in. (50 mm) of wear life. Blade is available in long-wearing 90 Shore A Durometer urethane.

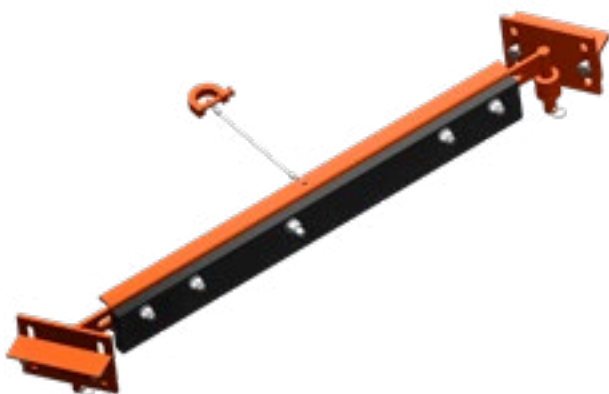

Martin® Diagonal Plow

MARTIN® DIAGONAL PLOW

For tail protection on reversing belts, specify the Martin® Diagonal Plow. Hung from brackets on both sides of the conveyor, the Martin® Diagonal Plow floats on the belt surface to remove material without needing adjustment. The sturdy PU blades with 90 Shore A hardness provides 1.5 in. (38 mm) of wear in service temperatures to 121°C and belt speeds up to 4.6 m/sec.

Alternatively, rubber blades can be supplied.

DUST MANAGEMENT

METHODS OF DUST MANAGEMENT

The amount of dust generated by a material handling system is governed by the relationship of three characteristics. The amount of Dust Generated is proportional to the Air Velocity divided by the factors of Particle Size and Material Cohesiveness. Any of the three characteristics of dust can be altered to minimize the amount of dust generated. Most dust management solutions target one or more of these characteristics.



CONTAINMENT

Minimize Air Velocity

Enclosing airborne dust with an effectively-designed transfer chute reduces air velocity by minimizing air drawn into the transfer point, sealing leaks that allow dust to escape, and allowing particles time to settle out of the air.



AIR FILTRATION

Increase Particle Size + Minimise Air Velocity

Air filtration systems minimise air velocity by pulling air and dust out of the material-handling system. They also increase the particle size of airborne dust by forcing particles to agglomerate before being deposited back into the material stream.

DUST MANAGEMENT



Air Cleaner with PowerCore® filters

MARTIN® AIR CLEANER

Filters dust-bearing air at transfer point without the ductwork or large fans of central ‘baghouse’ systems; returns material to stream. Compact filter replacement is simple – all filter media is changed from the ‘clean side’ and no confined space permit is required.

Application guidelines:

- Use to replace ‘bag house’ or central collectors
- Material is returned to material flow
- Moisture addition is not allowed
- Containment is required
- Applicable in hazardous (explosive) environments



MARTIN® DUST BAG

Allows positive pressure to escape while removing particles from air. Controls dust without power; self-cleans by collapsing when air flow stops. Dust bag must be the easiest path for air to escape the transfer point; effective containment including curtains is a must.

Application guidelines:

- No power consumption
- No water addition is desired
- Use when creating a passive path for air to flow
- Containment is required
- Applicable in hazardous (explosive) environments



Martin® Dust Bag

DUST MANAGEMENT

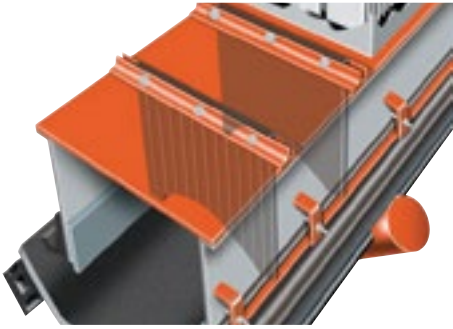

Martin® Dust Curtains

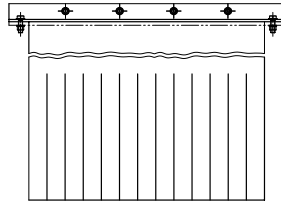

MARTIN® DUST CURTAINS

Installed near the end of the transfer point chute enclosure, Martin® Dust Curtains slow loading zone airflow to allow airborne dust to settle back into the belt cargo. Rugged solid or slit 6 mm rubber construction provides extended service in tough conditions. Curtains bolt into steel frame for simple replacement.

PRIMARY CLEANERS

Martin® PV Cleaner

Assembly P/N	PV1S
Blade P/N	PV-XXXXXXXX
Technical Data Sheet	L3736

Martin® QC1™ Cleaner HD

Assembly P/N	35382
Blade P/N	35381
Technical Data Sheet	L3370-07

Martin® QC1™ MT

Assembly P/N	QC1H
Blade P/N	QC1HC
Technical Data Sheet	L3823

Martin® QC1™ Cleaner XHD

Assembly P/N	35899
Blade P/N	35897
Technical Data Sheet	L3501

Martin® SHD 600 & 1200 Series Cleaners

Assembly P/N 600	41046
Assembly P/N 1200	41047
600 Series Blade P/N	35541
1200 Series Blade P/N	35540
SHD Turnbuckle Tensioner P/N	35600
SHD Spring-Link Tensioner P/N	35978
Technical Data Sheet	L3439

CleanScrape® Primary Cleaners

Assembly P/N	C1CXXRXXXXXX
Blade P/N	C1CXBRXXXXXX
Technical Data Sheet	L4040
Tensioner P/N	C1CTXXX

SECONDARY CLEANERS

Martin® SQC2™ Cleaner

Assembly P/N	41605
SQC2S™ Blade P/N	SC-10002
Rubber Buffer P/N	SC-10001
Technical Data Sheet	L3686

Martin® SQC2™ Cleaner Mini

Assembly P/N	41641
SQC2S™ Blade P/N	SCM-10002
Rubber Buffer P/N	SCM-10001
Technical Data Sheet	L3686

CleanScrape® Secondary Cleaner

Assembly P/N	C2C1S
Blade P/N	C2CBA
Technical Data Sheet	L4129

SPECIALTY CLEANERS

Martin® Brush Cleaner

Brush Assembly P/N	41580
Replacement Brush Segment P/N	41586
Technical Data Sheet	L3863

Martin® High Temperature Cleaner

Assembly P/N	21042
Tungsten Carbide Blade P/N	27924
Stainless Steel Blade P/N	16960
Technical Data Sheet	L3370-12

Martin® Washbox Cleaning System*

Dual Belt Cleaner Assembly P/N	WBPXX
Single Belt Cleaner Assembly P/N	WBSCPXX
Technical Data Sheet	L3780

TENSIONERS

Martin® Twist™ Tensioner

Single Tensioner P/N	38850
Dual Tensioner P/N	38850-2
Technical Data Sheet	L3839

Martin® Spring Tensioner

Tensioner P/N	38180
Dual Tensioner P/N	38180-2
Technical Data Sheet	L3370-16

Martin® Air Tensioner

Tensioner P/N	32745
Dual Tensioner P/N	32745-2R
Technical Data Sheet	L3370-16

ACCESSORIES

Martin® Inspection Doors

Stainless Steel Door P/N	CYA-XXXXMG-A2+E
Mild Steel Painted Door P/N	CYA-XXXXMG-P+E
Technical Data Sheet	L3432

BELT SUPPORT

Martin® Impact Cradle LD & MD

Medium Duty P/N	36318
Light Duty P/N	36010
Replacement Bar (UHMW)	39102
Standard Bar Length	1220 mm
Top Cover Material	UHMW

Martin® High-Speed Impact Cradle

P/N	HSRC
-----	------

Martin® Slider Cradle

P/N	30970
Replacement bars P/N	31275
Standard Bar Length	1220 mm
Bar Material	UHMW Polyethylene

SEALING SYSTEMS

Martin® ApronSeal™ Skirting

Sealing System Selection Guide	L3636
Single Skirting P/N	100724
Single Skirting HD P/N	100723
Double Skirting P/N	100873
Double Skirting HD P/N	100861
Material Durometer	60 or 70 (standard)
Continuous lengths	90 m
Trough Range	0° to 45°
Clamp Options	standard, low-profile, heavy-duty, quick release
Technical Data Sheet	L3298-10

Martin® External Wear Liner

P/N	38481
-----	-------

Martin® Self Adjusting Skirting HD

P/N	37911
Replacement Rubber P/N	37911-R
Continuous Lengths	30 m
Min. belt edge requirement	30 mm

Martin® Self Adjusting Skirting XHD

Assembly P/N	41720
Replacement Rubber P/N	41721
Continuous Lengths	10 m
Min. belt edge requirement	58 mm
Technical Data Sheet	L4005

BELT TRACKING

Martin® Tracker™

Standard P/N	41142-BA
Heavy Duty P/N	41142-HD
Extra Heavy Duty P/N	41142-MO

Martin® Tracker™ Reversing

Lower Standard P/N	41143-B
Lower P/N	41143-HD

Martin® Roller Tracker

P/N	MRT
Max. Belt Speed	5 m/s

TAIL PULLEY PROTECTION

Martin® Torsion VPlow Plus

Assembly P/N	CPVTAS
Urethane Blade Nose	CPVTB001X
Urethane Side Blade	CPVTBSXXX
Technical Data Sheet	L4120

Martin® VPlow Modular

Assembly P/N	CPVHAS
Urethane Blade Nose	CPVHB001X
Urethane Side Blade	CPVHBSXXX
Technical Data Sheet	L4099

Martin® Diagonal Plow

P/N	22662
Rubber Blade P/N	24112
Urethane Blade P/N	25403
Max. Belt Speed:	4,6 m/s
Blade Material:	Rubber or Urethane
Technical Data Sheet	L3298-12

DUST MANAGEMENT

Martin® Dust Bag

P/N Ø 610 mm	34840
P/N Ø 305 mm	34839
Technical Data Sheet	L3298-07

Martin® Air Cleaner

P/N	41730
Technical Data Sheet	L3906-02

* Martin provides customized versions to suit your specific applications. Contact Martin for more details.

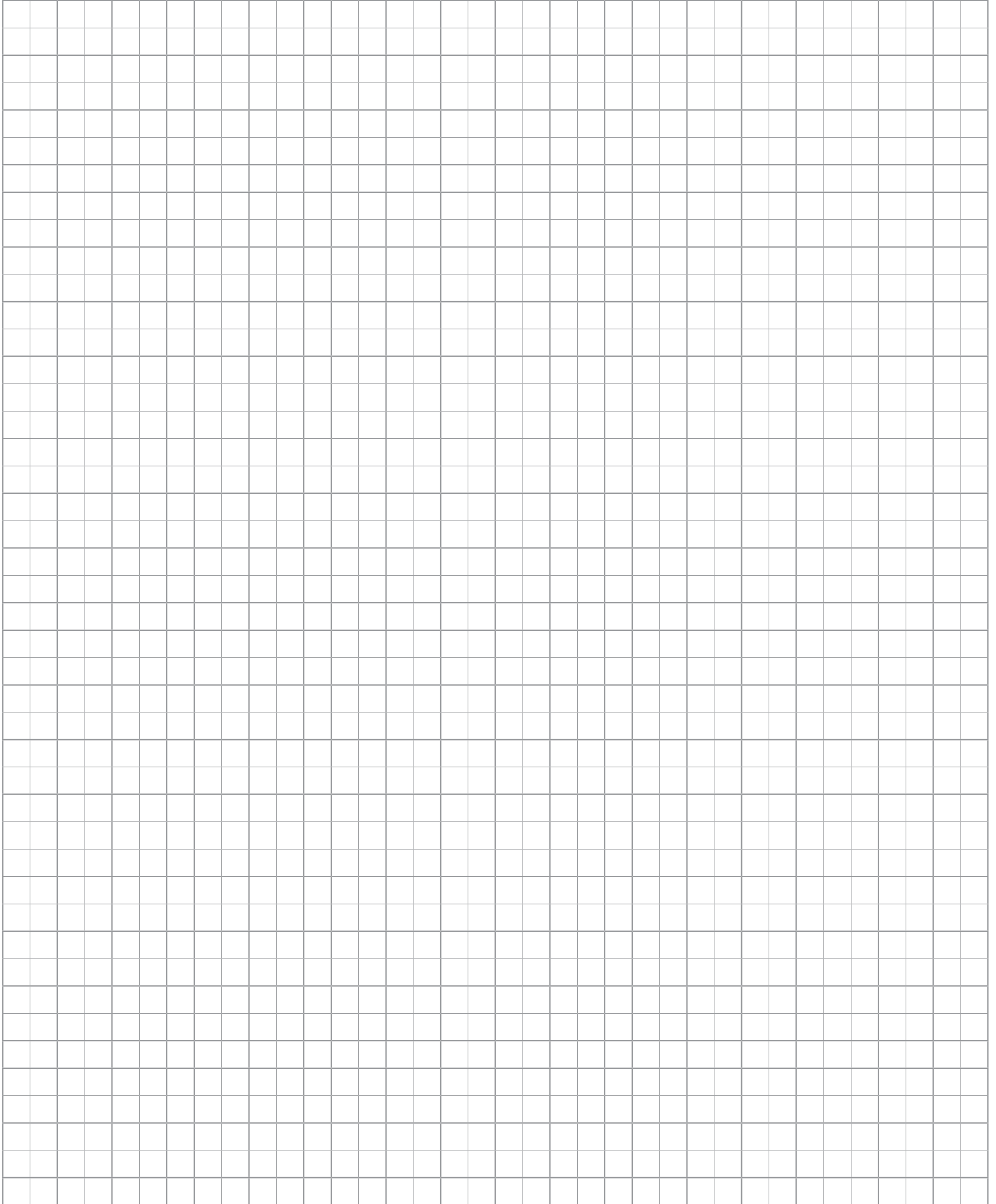

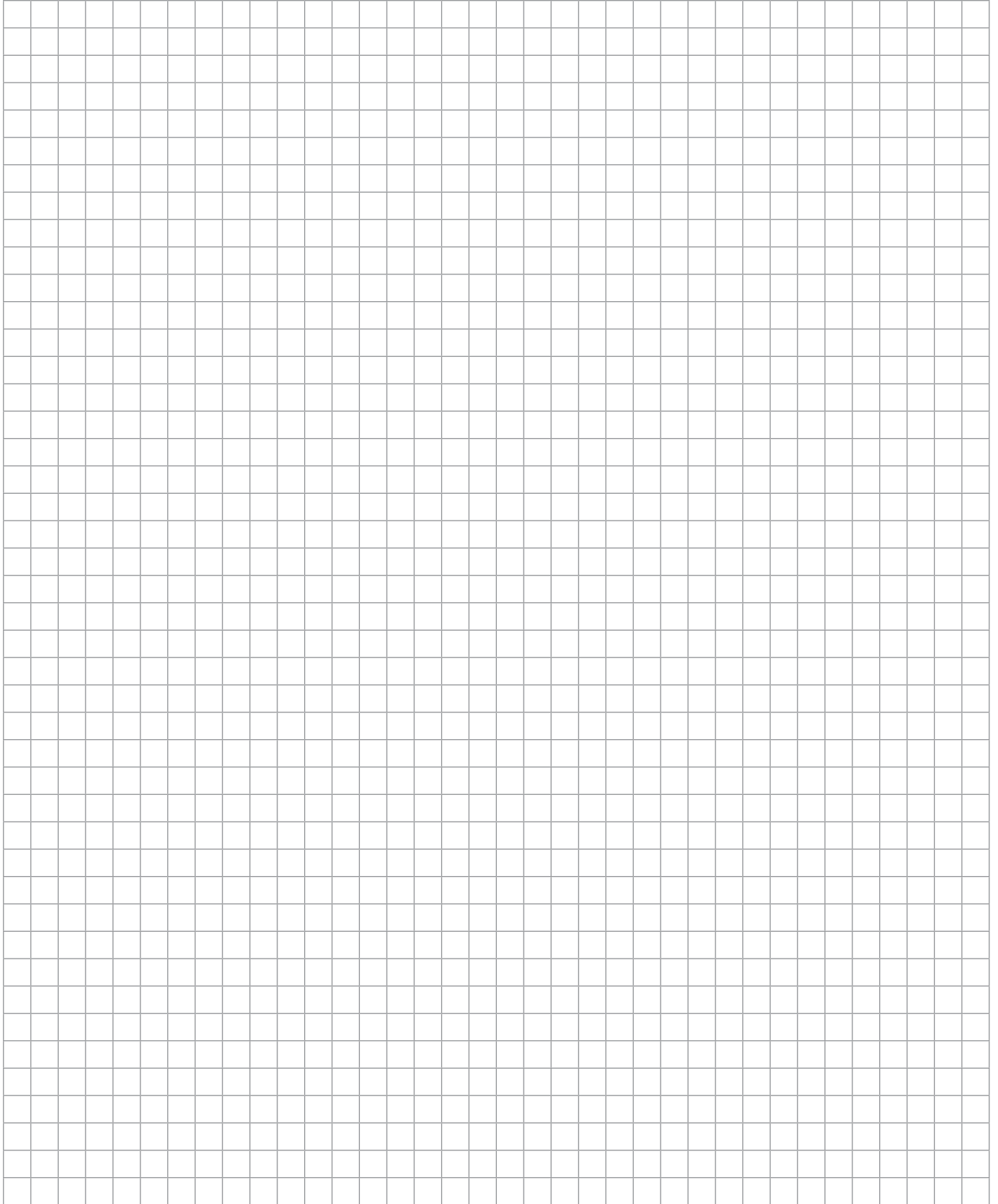



GLOBAL LOCATIONS



UNITED STATES



AUSTRALIA



BRAZIL



CHINA



FRANCE



GERMANY



INDIA



INDONESIA



ITALY



MALAYSIA



MEXICO



PERU



SPAIN



SOUTH AFRICA



TURKEY



UNITED KINGDOM

Authorized representatives in over 32 additional countries

MARTIN ENGINEERING LTD

The Tangent Hub,
Unit 33, Weighbridge Rd,
Shirebrook, Mansfield,
NG20 8RX,
UK

Tel.: +44 (0)1159 464746

info@martin-eng.co.uk

www.martin-eng.co.uk

Part No. L4119-04/24