

PART NUMBER	BELT WIDTH	DIM "A" FRAME LENGTH	DIM "B" BLADE WIDTH
SQC2S-18X12XXXXX	18.00 [400-500]	48.00 [1219]	11.81 [300]
SQC2S-18X18XXXXX	18.00 [400-500]	48.00 [1219]	17.72 [450]
SQC2S-24X18XXXXX	24.00 [500-650]	54.00 [1372]	17.72 [450]
SQC2S-24X24XXXXX	24.00 [500-650]	54.00 [1372]	23.62 [600]
SQC2S-30X24XXXXX	30.00 [350-800]	60.00 [1524]	23.62 [600]
SQC2S-30X30XXXXX	30.00 [350-800]	60.00 [1524]	29.53 [750]
SQC2S-36X30XXXXX	36.00 [800-1000]	66.00 [1676]	29.53 [750]
SQC2S-36X35XXXXX	36.00 [800-1000]	66.00 [1676]	35.43 [900]
SQC2S-42X35XXXXX	42.00 [100-1200]	72.00 [1829]	35.43 [900]
SQC2S-42X41XXXXX	42.00 [100-1200]	72.00 [1829]	41.34 [1050]
SQC2S-48X41XXXXX	48.00 [1200-1400]	78.00 [1981]	41.34 [1050]
SQC2S-48X47XXXXX	48.00 [1200-1400]	78.00 [1981]	47.24 [1200]
SQC2S-54X47XXXXX	54.00 [1400-1600]	84.00 [2134]	47.24 [1200]
SQC2S-54X53XXXXX	54.00 [1400-1600]	84.00 [2134]	53.15 [1350]
SQC2S-60X53XXXXX	60.00 [1600-1800]	90.00 [2286]	53.15 [1350]
SQC2S-60X59XXXXX	60.00 [1600-1800]	90.00 [2286]	59.06 [1500]
SQC2S-66X59XXXXX	66.00 [1600-1800]	96.00 [2438]	59.06 [1500]
SQC2S-66X65XXXXX	66.00 [1600-1800]	96.00 [2438]	64.96 [1650]
SQC2S-72X65XXXXX	72.00 [1800-1900]	102.00 [2591]	64.96 [1650]
SQC2S-72X71XXXXX	72.00 [1800-1900]	102.00 [2591]	70.87 [1800]
SQC2S-78X71XXXXX	78.00 [1900-2000]	108.00 [2743]	70.87 [1800]
SQC2S-78X77XXXXX	78.00 [1900-2000]	108.00 [2743]	76.77 [1950]
SQC2S-84X77XXXXX	84.00 [2000-2100]	114.00 [2896]	76.77 [1950]
SQC2S-84X83XXXXX	84.00 [2000-2100]	114.00 [2896]	82.68 [2100]
SQC2S-90X83XXXXX	90.00 [2100-2200]	120.00 [3048]	82.68 [2100]
SQC2S-90X89XXXXX	90.00 [2100-2200]	120.00 [3048]	88.58 [2250]
SQC2S-96X89XXXXX	96.00 [2200-2400]	126.00 [3200]	88.58 [2250]
SQC2S-96X95XXXXX	96.00 [2200-2400]	126.00 [3200]	94.49 [2400]
SQC2S-108X100XXXXX	108.00 [2700-2800]	138.00 [3505]	100.39 [2550]
SQC2S-120X112XXXXX	120.00 [3000-3100]	150.00 [3810]	112.20 [2850]

PART NUMBER	BELT WIDTH	DIM "A" FRAME LENGTH	DIM "B" BLADE WIDTH
SQC2S-18X12XXEXX	18.00 [400-500]	66.00 [1676]	11.81 [300]
SQC2S-18X18XXEXX	18.00 [400-500]	66.00 [1676]	17.72 [450]
SQC2S-24X18XXEXX	24.00 [500-650]	72.00 [1829]	17.72 [450]
SQC2S-24X24XXEXX	24.00 [500-650]	72.00 [1829]	23.62 [600]
SQC2S-30X24XXEXX	30.00 [350-800]	78.00 [1981]	23.62 [600]
SQC2S-30X30XXEXX	30.00 [350-800]	78.00 [1981]	29.53 [750]
SQC2S-36X30XXEXX	36.00 [800-1000]	84.00 [2134]	29.53 [750]
SQC2S-36X35XXEXX	36.00 [800-1000]	84.00 [2134]	35.43 [900]
SQC2S-42X35XXEXX	42.00 [100-1200]	90.00 [2286]	35.43 [900]
SQC2S-42X41XXEXX	42.00 [100-1200]	90.00 [2286]	41.34 [1050]
SQC2S-48X41XXEXX	48.00 [1200-1400]	96.00 [2438]	41.34 [1050]
SQC2S-48X47XXEXX	48.00 [1200-1400]	96.00 [2438]	47.24 [1200]
SQC2S-54X47XXEXX	54.00 [1400-1600]	102.00 [2591]	47.24 [1200]
SQC2S-54X53XXEXX	54.00 [1400-1600]	102.00 [2591]	53.15 [1350]
SQC2S-60X53XXEXX	60.00 [1600-1800]	108.00 [2743]	53.15 [1350]
SQC2S-60X59XXEXX	60.00 [1600-1800]	108.00 [2743]	59.06 [1500]
SQC2S-66X59XXEXX	66.00 [1600-1800]	114.00 [2896]	59.06 [1500]
SQC2S-66X65XXEXX	66.00 [1600-1800]	114.00 [2896]	64.96 [1650]
SQC2S-72X65XXEXX	72.00 [1800-1900]	120.00 [3048]	64.96 [1650]
SQC2S-72X71XXEXX	72.00 [1800-1900]	120.00 [3048]	70.87 [1800]
SQC2S-78X71XXEXX	78.00 [1900-2000]	126.00 [3200]	70.87 [1800]
SQC2S-78X77XXEXX	78.00 [1900-2000]	126.00 [3200]	76.77 [1950]
SQC2S-84X77XXEXX	84.00 [2000-2100]	132.00 [3353]	76.77 [1950]
SQC2S-84X83XXEXX	84.00 [2000-2100]	132.00 [3353]	82.68 [2100]
SQC2S-90X83XXEXX	90.00 [2100-2200]	138.00 [3505]	82.68 [2100]
SQC2S-90X89XXEXX	90.00 [2100-2200]	138.00 [3505]	88.58 [2250]
SQC2S-96X89XXEXX	96.00 [2200-2400]	144.00 [3658]	88.58 [2250]
SQC2S-96X95XXEXX	96.00 [2200-2400]	144.00 [3658]	94.49 [2400]
SQC2S-108X100XXEXX	108.00 [2700-2800]	156.00 [3962]	100.39 [2550]
SQC2S-120X112XXEXX	120.00 [3000-3100]	168.00 [4267]	112.20 [2850]

BLADE CHART		
PART NO.	COLOR	GENERAL APPLICATION
SQC2S-XXCXXXXXXX	----	CORROSION RESISTANT WITH CLIPS
SQC2S-XXRXXXXXXX	ORANGE	GENERAL CONDITIONS REV BELT WITH CLIPS
SQC2S-XXSXXXXXXX	----	CORROSION RESISTANT

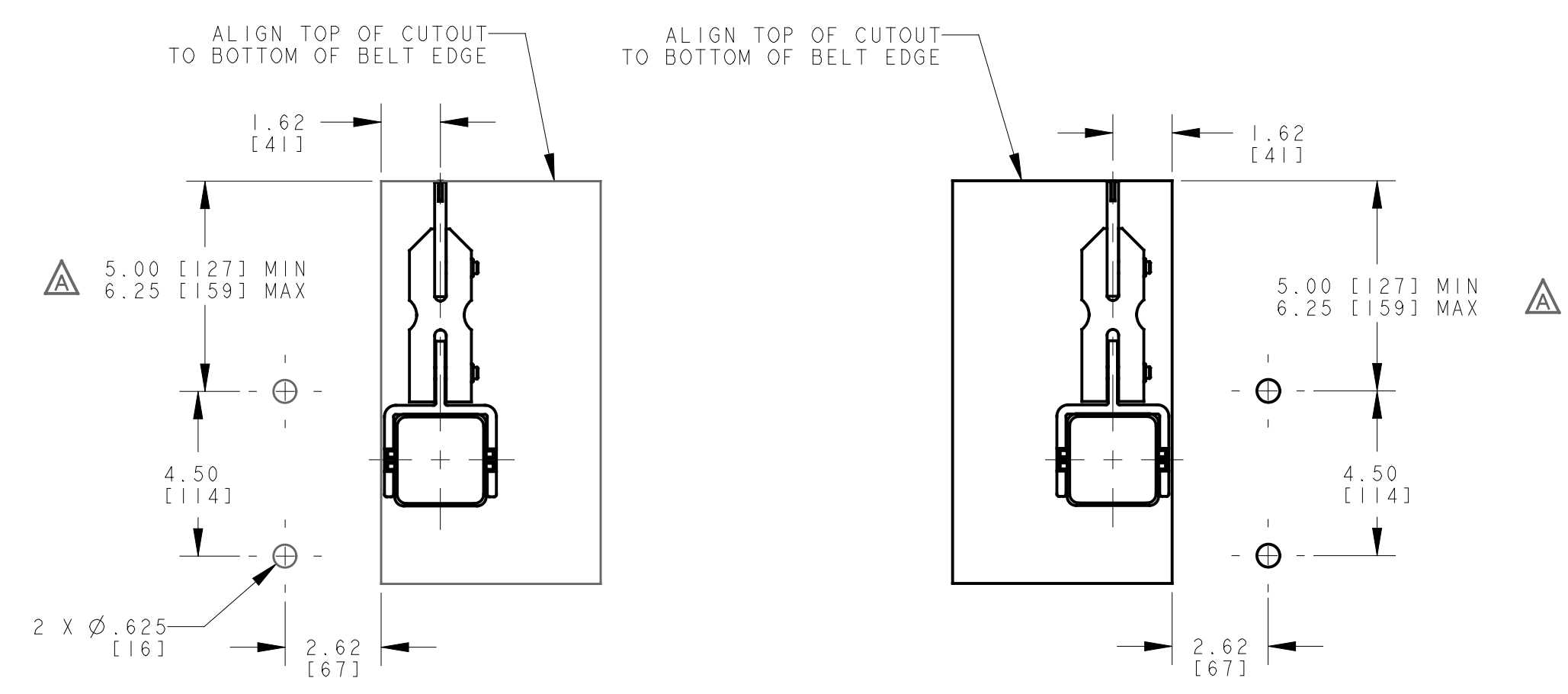

CHUTE CUTOUT DETAIL WITH TENSIONER MOUNTED ON THE LEFT SIDE SEE NOTE 10

CHUTE CUTOUT DETAIL WITH TENSIONER MOUNTED ON THE RIGHT SIDE SEE NOTE 10

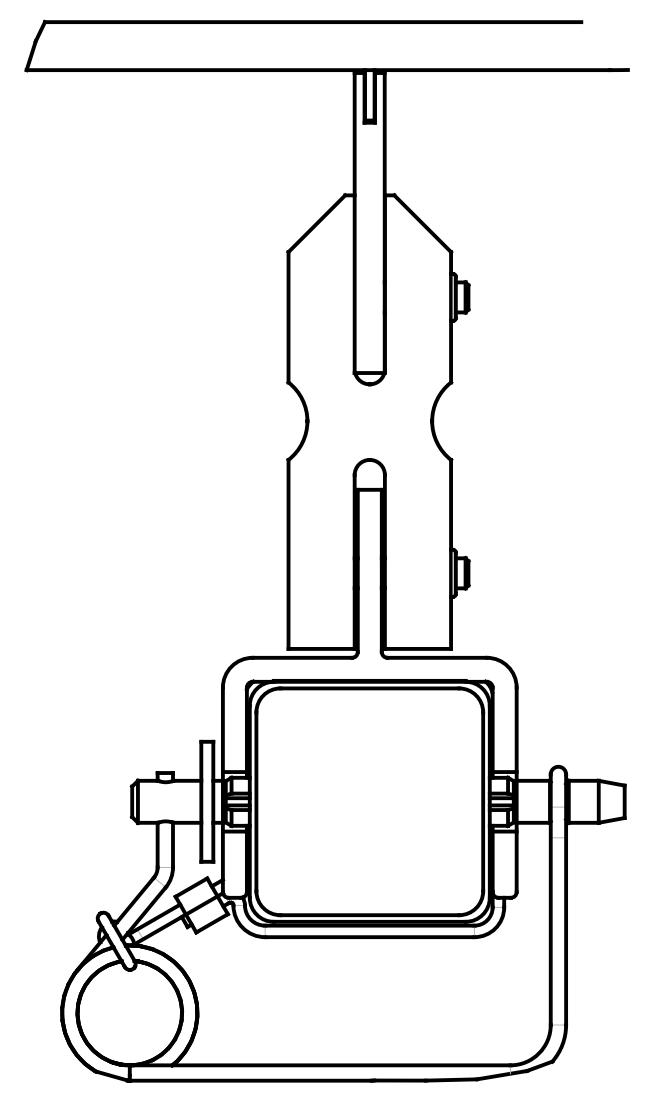

BLADE INSTALLATION DETAIL SCALE 1/2

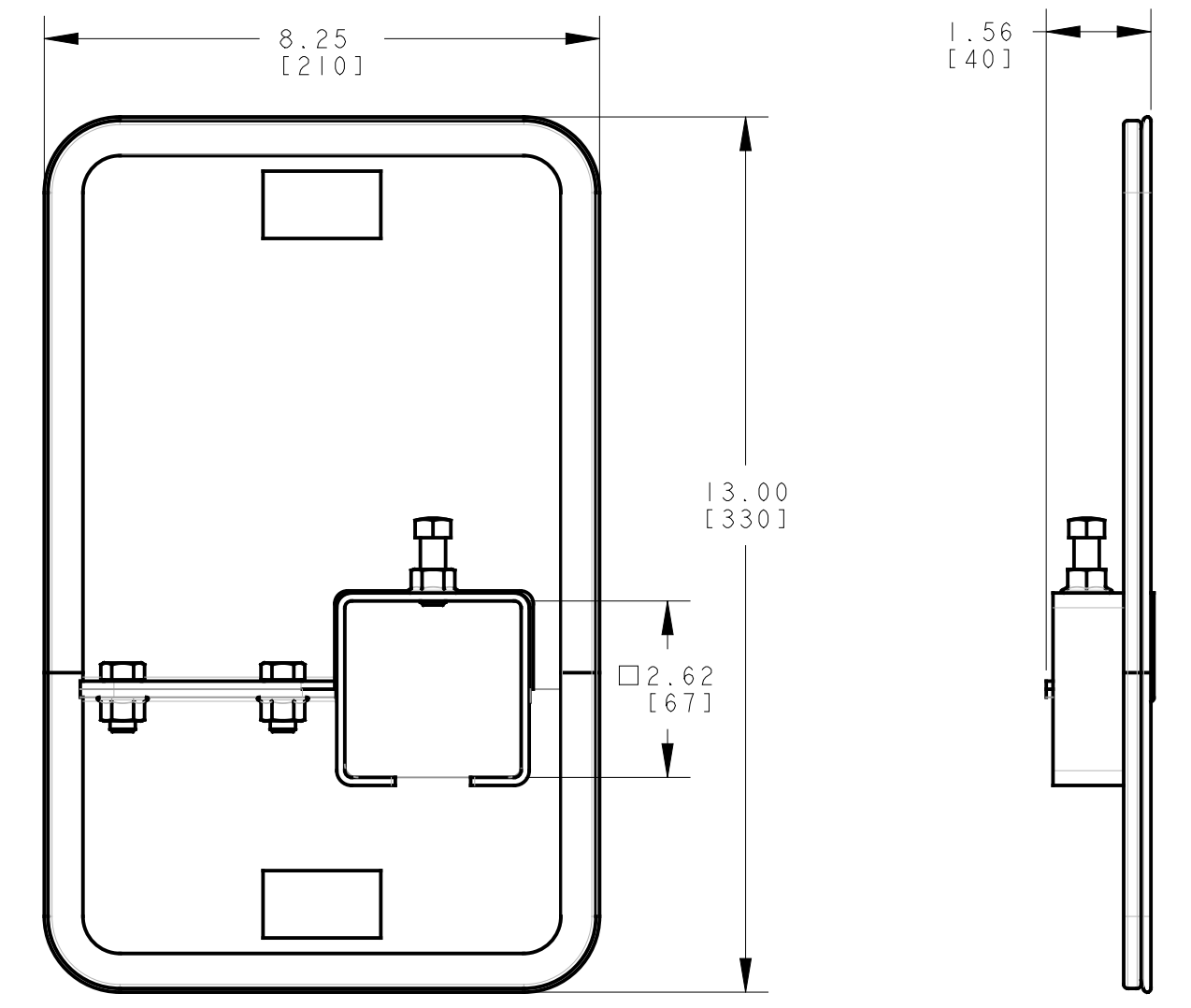

DUST TIGHT COVER DOOR DETAIL SCALE 3/8

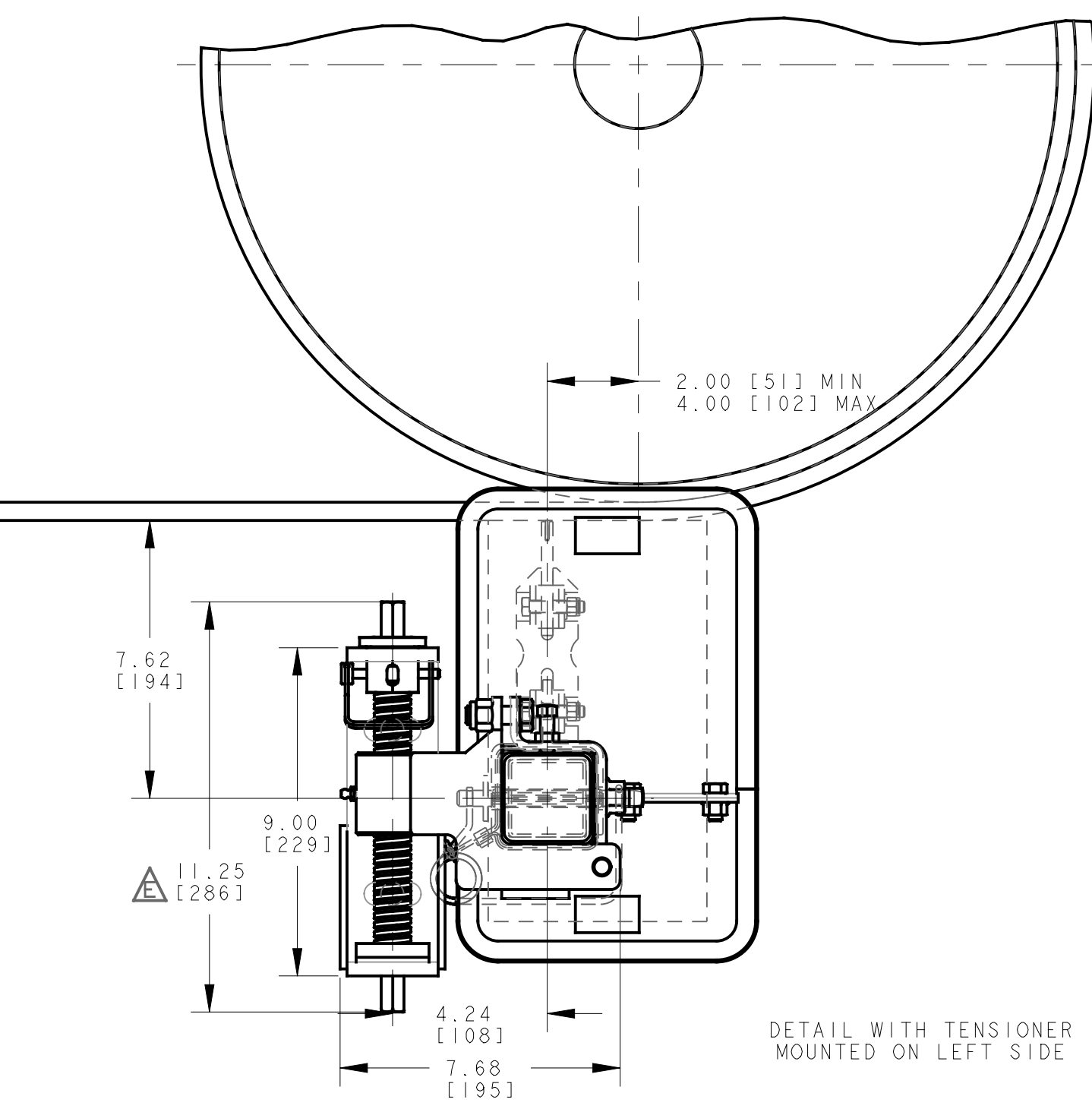

DETAIL WITH TENSIONER MOUNTED ON LEFT SIDE

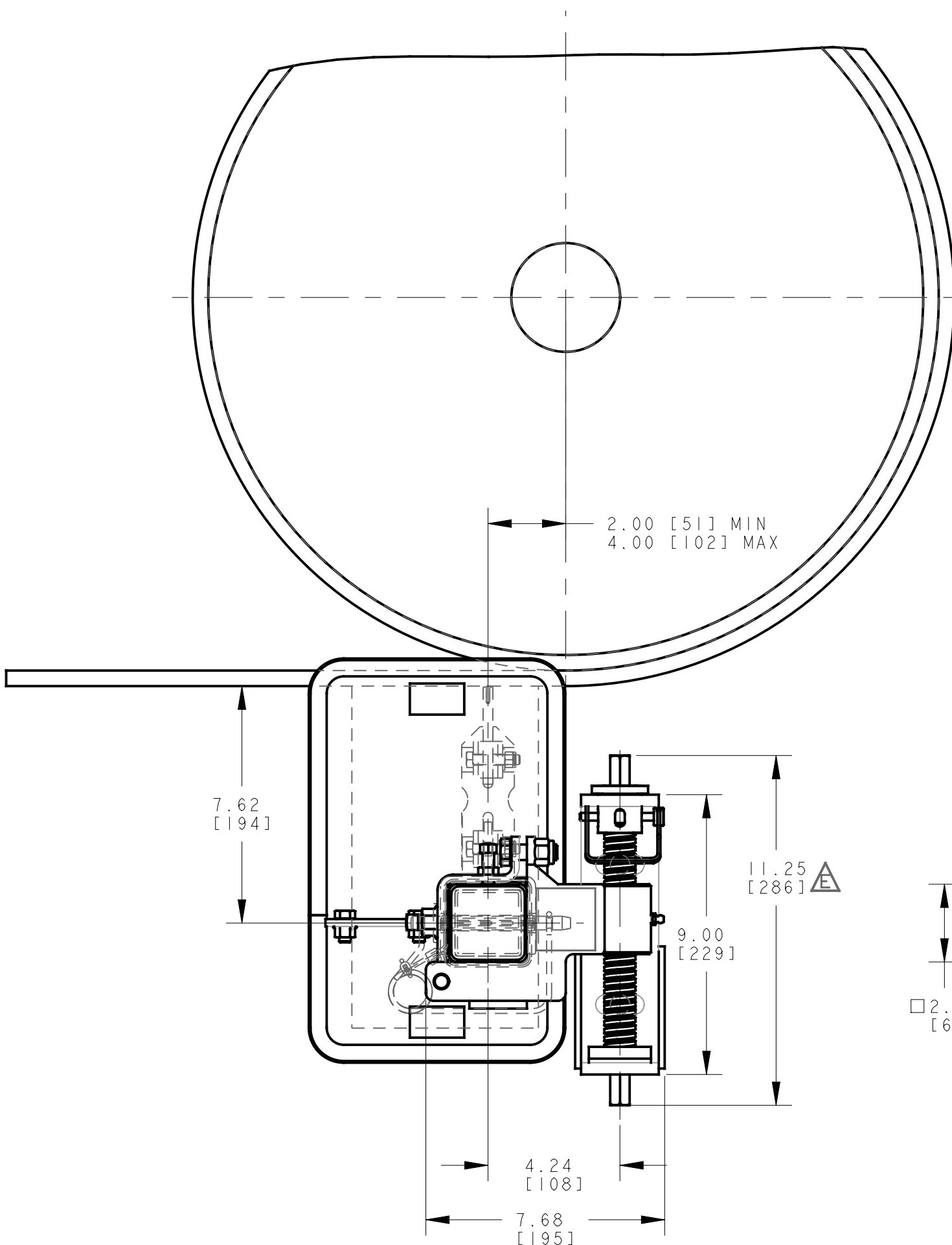

DETAIL WITH TENSIONER MOUNTED ON RIGHT SIDE

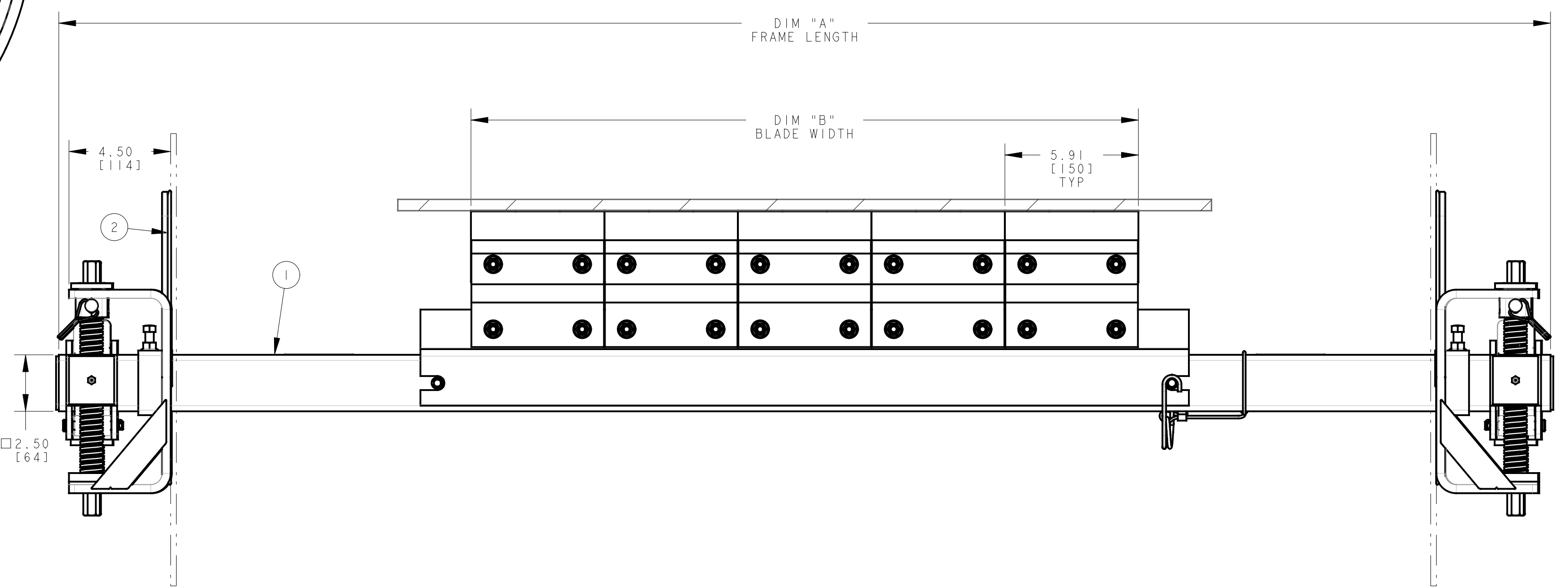

- NOTES:
- 1) ALL DIMENSIONS ARE GIVEN IN INCHES [MM].
 - 2) ALL DIMENSIONS ARE FOR REFERENCE ONLY.
 - 3) FOR EASE OF ACCESSIBILITY AND MAINTENANCE MARTIN ENGINEERING RECOMMENDS BOLTING CLEANER TO EXISTING STRUCTURE WHEN APPLICABLE.
 - 4) DUE TO STRUCTURAL TOLERANCES IN THE FIELD, DIMENSIONS AND LOCATIONS MAY VARY.
 - 5) WHERE EXTREME AND UNUSUAL CONDITIONS EXIST, OR SPECIAL MAINFRAME LENGTHS ARE REQUIRED, CONTACT MARTIN ENGINEERING.
 - 6) CUSTOMER MAY HAVE TO MODIFY STRUCTURE TO PROPERLY INSTALL CLEANER.
 - 7) REFER TO OPERATOR'S MANUAL (M3820) FOR ADDITIONAL AND OPTIONAL INSTALLATION INSTRUCTIONS.
 - 8) MARTIN ENGINEERING RECOMMENDS POSITIONING OF AN IDLER FOR PROPER BACKING SUPPORT OF THE SCORPIO BLADE IF NOT LOCATED LOCATED ON THE HEAD PULLEY.

- NOTES (CONT'D):
- 9) MAINFRAME IS SUPPLIED LONGER THAN REQUIRED, FIELD CUT TO DESIRED LENGTH.
 - 10) LOCATE AND DRILL HOLES FOR TENSIONER BEFORE LOCATING ACCESS WINDOW. NOTE TENSIONER LT/RT MOUNTING DIRECTION.
 - 11) IN THE CLEANER PART NUMBER THE SQ2 INDICATES A MARTIN SQ2 QUICK-CHANGE SECONDARY CLEANER, THE NEXT TWO DIGITS INDICATE THE BELT WIDTH, THE NEXT DIGIT INDICATES THE BLADE TYPE (SEE BLADE CHART), THE NEXT TWO DIGITS INDICATE THE BLADE CLEANING WIDTH, THE NEXT TWO DIGITS INDICATE THE BLADE BUFFER TYPE (MR FOR STD RUBBER, FR FOR FLAME RETARDANT RUBBER), THE NEXT DIGIT INDICATES THE MAINFRAME OPTIONS (E = EXTENDED LENGTH PAINTED STEEL MAINFRAME, P = PAINTED MAINFRAME, S = STAINLESS STEEL MAINFRAME), THE NEXT DIGIT INDICATES IF A TENSIONER IS INCLUDED (T IS WITH TENSIONER, 0 IS WITHOUT), THE LAST DIGIT IS FOR ADDITIONAL OPTIONS (D = DUST TIGHT STEEL COVER DOOR).

©Copyright 2024 Martini Engineering. All rights reserved. Covered by U.S. and foreign patents pending and issued. ® and TM indicate trademarks of Martini Engineering.			
		MARTIN ENGINEERING NEPONSET, IL USA	
F	ADDED P/N SQC2S-96X95XXXX, -108X100XXXX, -120X112XXXX & SQC2S-96X95XXEXX, -108X100XXEXX & -120X112XXEXX TO CHARTS (P/14650)	----	02/08/24 JAH
E	CHGD DIM 10.28 TO 11.25	15706	09/02/20 JAH
D	CHGD MANUAL P/M IN NOTE FROM M3682 TO M3820	15452	08/29/19 JAH
C	RMVD P/M SQC2S-XXGXXXX & -XXHXXXX FROM BLADE CHART	14653	09/22/16 JAH
B	ADDED CHART W/EXTENDED MAINFRAME DIM'S/ADDED SQC2S-XXCXXXX & -XXSXXXX TO CHART	----	04/26/13 MJB
A	UPDATED MILLIMETER DIMENSIONS FOR DIM "B" / CHGD DIM FROM 5.75 MIN TO 5.00 MIN	13161	09/06/11 RND
NO.	DESCRIPTION	ECN	DATE BY
REVISION			
		PR11691	S50081

TITLE	MARTIN® SQC2™ SQ MNFRM SECONDARY BELT CLEANER DUST TIGHT COVER DOOR	DRAWN	MJB
		DATE	10/12/10
		CHECKED	
		ENG.	JAP
		DATE	02/04/11
		APPROVED	DM
		DATE	02/04/11
		SCALE	1/4