



BELT CLEANERS

CARRYBACK REMOVAL SOLUTIONS FOR ALL APPLICATIONS

L3651



PROBLEM

CONSEQUENCES OF CARRYBACK

Carryback is material that sticks to the belt past the discharge point and then drops off along the conveyor's return run.

Without belt cleaners, prevalent carryback causes...

- Reduced operating efficiency and profitability through increased expenses for maintenance and cleanup and the loss of material.
- Material buildup on rolling components leading to seized idlers, wandering belts and increased power consumption.
- Lower plant morale as employees sense the "I don't care if it's dirty" attitude.
- Unsafe working conditions caused by material accumulation on floors and walkways, creating fire hazards and slip/trip hazards.
- Health hazards and environmental concerns created by airborne material.
- Unfavorable attention from neighbors and regulatory agencies.





SOLVED

CARRYBACK REMOVAL SOLUTION

Belt cleaner systems from Martin Engineering make conveyor systems cleaner, safer and more productive.

With belt cleaners, minimalized carryback results in...

- Improved maintenance planning and conveyor availability as emergency outages, unscheduled downtime and “hurry-up” repairs are reduced.
- Reduced maintenance expenses by lower labor costs for fewer and faster service procedures. Improved manpower utilization by fewer belt-tracking and material-cleanup chores.
- Maximized equipment life by fewer replacements of prematurely worn components damaged by fugitive material and buildup.
- Improved working conditions and plant safety and morale by better housekeeping.
- Improved community relations and regulatory compliance by reducing environmental pollution.

PRIMARY CLEANERS

MARTIN® PRIMARY CLEANERS

As the first stage in a multiple cleaner system, the primary cleaner removes the majority of material adhered to the belt, leaving only a thin layer of sticky fines.

Primary cleaners are generally tensioned at low pressure—roughly 2 psi (13.8 kPa)—against the belt. Low blade-to-belt pressure allows the primary cleaner to be positioned at a peeling angle against the belt. The use of higher pressure at this angle would endanger the belt, splice or cleaner itself.

Primary cleaners are typically installed on the face of the head pulley, just below the material trajectory. The cleaner should be constructed to avoid material buildup and installed so that it is out of the material stream.

SELECTION GUIDE

Required Data

Belt width
Head pulley diameter
Belt speed
Material characteristics
Application temperature

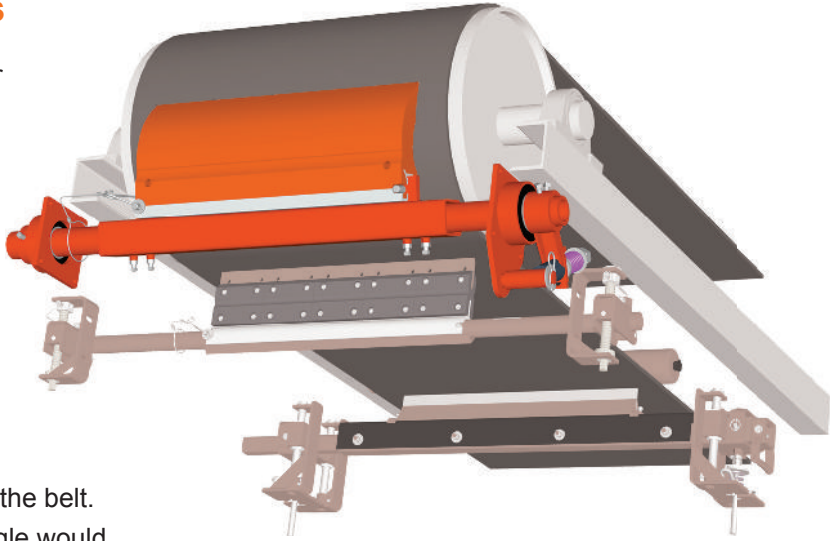

Selection Process

1. Identify the specifications for your conveyor.
2. Use your conveyor's specifications for **belt width** and **pulley diameter** to select a primary cleaner in the Primary Cleaner Sizing Chart on the opposite page.
3. Check your selection against the recommended **maximum belt speeds** in the Primary Cleaner Scale Chart on the opposite page.
4. Use **material characteristics** and **application temperature** to identify the appropriate urethane blade in the chart on page 6.



PRIMARY CLEANER SIZING CHART

Belt Width in. (mm)	Head Pulley Diameter—in. (mm)						
	7-10 (180-250)	12-16 (300-400)	18-22 (450-560)	24-30 (600-760)	32-38 (810-970)	40-46 (1010-1170)	48+ (1220+)
12 (300-400)		1	N/A	N/A	N/A	N/A	N/A
18 (400-500)		1 or 3	2 or 3 or 4	3 or 5 or 6	N/A	N/A	N/A
24 (500-650)		1 or 3	2 or 3 or 4	3 or 5 or 6	3	3	N/A
30 (650-800)		1 or 3	2 or 3 or 4	3 or 5 or 6	3	3	N/A
36 (800-1000)		1 or 3	2 or 3 or 4	3 or 5 or 6	3	3	N/A
42 (1000-1200)	1	1 or 3	2 or 3 or 4	3 or 5 or 6	3 or 7	3	3
48 (1200-1400)	1	1	2 or 4	3 or 5 or 6	3 or 7	3 or 7	3 or 8
54 (1400-1600)	1	1	2 or 4	3 or 5 or 6	3 or 7	3 or 7	3 or 8
60 (1600-1800)	1	1	2 or 4	3 or 5 or 6	3 or 7	3 or 7	3 or 8
72 (1800-2000)	1	1	2 or 4	3 or 5 or 6	3 or 7	3 or 7	3 or 8
84 (2000-2200)	N/A	2 or 4	2 or 4	5 or 6	3 or 7	3 or 7	3 or 8
96 (2200-2400)	N/A	2 or 4	2 or 4	5 or 6	3 or 7	3 or 7	3 or 8
108 (2600-2800)	N/A	4	4	N/A	3 or 7	3 or 7	3 or 8
120 (2800-3000)	N/A	N/A	N/A	N/A	3 or 7	3 or 7	3 or 8

1 = PV Cleaner

2 = QC1™ Cleaner HD

3 = CleanScrape® Cleaner

4 = QC1™ QC1™ Cleaner PD

5 = QC1™ Cleaner HD Max

6 = QC1™ Cleaner XHD

7 = SHD 600 Series Cleaner

8 = SHD 1200 Series Cleaner

Please note: Stainless steel mainframes and tensioners are available for corrosive environments.

“Safe to Service” cleaners available for primary or secondary.

PRIMARY CLEANER SCALE & BELT SPEEDS

Maximum Belt Speed by Categories: fpm (m/sec)

Blade Dimensions given in inches (mm)

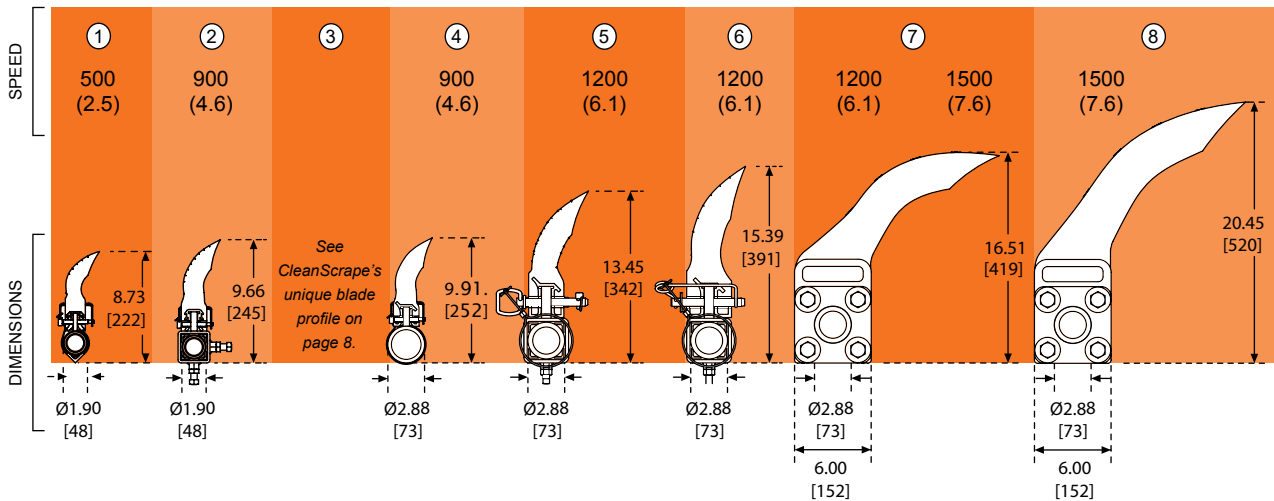

In instances of conflict between size and speed, choose the next larger size.

PATENTED CARP CLEANER BLADES

Martin belt cleaner blades come in a large array of shapes, sizes and materials to most effectively remove any type of material carryback while protecting the belt and its splices.

Martin's patented Constant-Angle/Constant-Area Radial Pressure (CARP) blade design maintains consistent cleaning through all stages of blade wear.

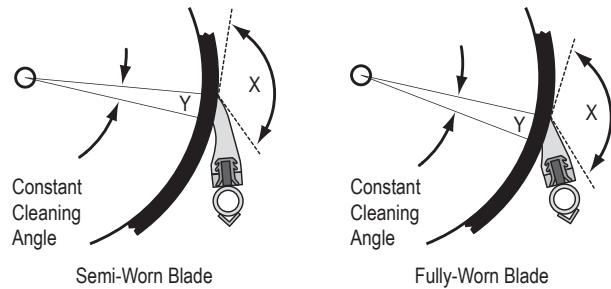

Martin® CARP Blades are protected by U.S. Patent No. 4,917,231.

MARTIN® HIGH-PERFORMANCE URETHANES

Martin Engineering is the worldwide leader in the development of high-performance urethanes for specialized applications. Available for any Martin primary and secondary cleaners, as well as any primary cleaner supplied by another manufacturer.

SELECTION GUIDE

Color	Application Description	Typical Materials	Temperature Range
Orange (blank or OR)	Standard Martin® Urethane is suitable for most applications, including abrasive conditions and exposure to solvents or oil.	Bauxite, coke, coal, refuse, steel/ore, etc.	-20° to 160°F (-30° to 70°C)
Brown (BR)	Chemical-Resistant Urethane provides improved resistance to chemicals and reduced water absorption in high-moisture environments.	Limestone, Coal, Ore, etc.	-40° to 160°F (-40° to 70°C)
Green (GR)	High-Temperature Urethane withstands exposure to intermittent temperatures of up to 350°F (177°C).	Clinker	-40° to 300°F (-40° to 150°C)
Tan (CL)	Low-Rigidity Urethane is ideal for dry products such as sand and gravel.	Gravel, dry sand	-20° to 160°F (-30° to 70°C)
Navy Blue (NB)	Low-Adhesion Urethane is ideal for sticky or tacky materials.	Cement, glass, wood chips	-20° to 160°F (-30° to 70°C)
Yellow (CY)	Ceramic Bead is ideal for aggressive applications	Cement, glass, wood chips, etc.	-40° to 160°F (-40° to 70°C)



MARTIN® QC™ BLADE REPLACEMENT

One-pin blade replacement makes belt cleaner blade replacement an easy, one-minute, no-tool operation performed from outside of the chute. Simply (1) remove the R-clip and (2) slide the hitch pin out of the mainframe extrusion to (3) release the blade.

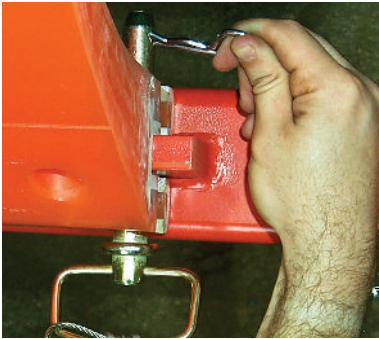

1 Remove the R-clip.

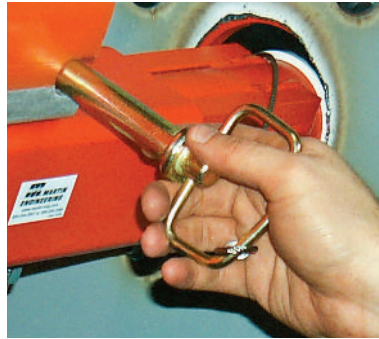

2 Slide the hitch pin out.

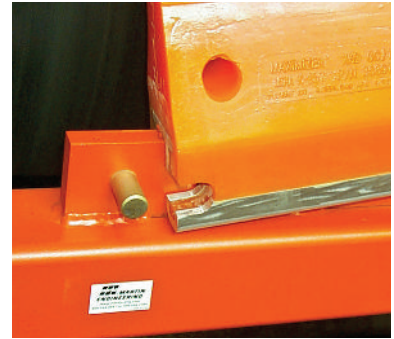

3 Release the blade.

MARTIN® QC1™ BLADE OPTIONS

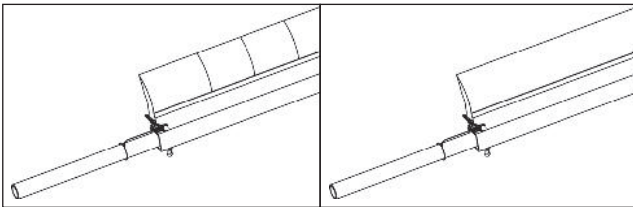

*Segments only
XX10
(for crowned head pulleys)*

*No segments
XX11*

CLEANSRAPE® CLEANER

The CleanScape® Cleaner lasts up to four times as long as traditional belt cleaners. Safe for use on mechanical and vulcanized splices, this metal-tipped cleaner provides aggressive cleaning without compromising your belt. Requiring minimal ongoing maintenance, CleanScape® needs only one tensioner adjustment—EVER. Installed at an angle, very little space for installation is required.



Get a quote based on your specifications: www.martin-eng.co.id/cleanscape

SPECIFICATIONS

Cleaner Type	Pulley Diameter mm (in.)		Belt Width mm (in.)	Maximum Belt Speed m/s (fpm)	
	Min.	Max.		Vulcanized Splice	Mechanical Splice
C1CSXRXXXXXX	300 (12)	550 (22)	400–1000 (18-42)	6 (1200)	4 (800)
C1CMXRXXXXXX	550 (22)	900 (34)	500–1800 (18-72)	8 (1500)	4 (800)
C1CLXRXXXXXX	900 (36)	1250 (50)	800–2400 (24-96)	8 (1500)	4 (800)
C1CHXRXXXXXX	800 (32)	2000 (78)	1000-3000 (42-120)	8 (1500)	6 (1200)

CARBIDE BLADE SELECTION

Carbide Selection	Application Description	Typical Materials
A	Suitable for less abrasive products and medium belt speeds. Applicable with mechanical belt splices.	Limestone, gypsum, potash
B	Suitable for moderate abrasive products and medium belt speeds. Applicable with mechanical belt splices.	Sand, coal, salt, ore, sugar
C	Suitable for extremely abrasive materials and highest belt speeds. Do not use with mechanical belt splices.	Quartz sand, ash, ore, hardstone, slag, sinter

*H available only with carbide B.



MARTIN® PV CLEANER

One-piece blade contains approximately 20 percent more urethane than comparable pre-cleaners, extending service life.

Uses an aggressive angle of attack to the belt to increase cleaning efficiency.

Allows “one-pin, no-tool” blade replacement.
Drop the sturdy blade into place on the reinforced steel mainframe and secure it with a wire lock pin.

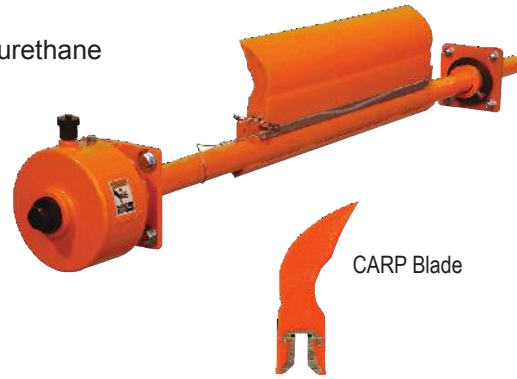

MARTIN® QC1™ CLEANER HD

One-pin blade replacement makes belt cleaner blade replacement an easy, one-minute, no-tool operation.

Patented “CARP” blade design maintains cleaning performance through all stages of belt cleaner blade life.

Optional tungsten-tipped steel blade inserts are available for QC1™ Cleaner HD. Not for use on belts with mechanical splices—vulcanized belts only.



MARTIN® QC1™ CLEANER PD *

Sturdy mainframe—2.875 in (73 mm) OD Schedule 80 steel pipe stands up to rugged conditions, large pulleys and heavy material loads.

The high-volume “CARP” blade features 20 percent more urethane than competitive cleaners.

Durable and rugged spring tensioner maintains cleaning pressure, yet allows easy re-tensioning with minimal downtime.

Saves money at purchase by reducing the need for maintenance and blade replacements.



MARTIN® QC1™ CLEANER HD MAX

Unique blade profile means the blade maintains the most efficient cleaning angle across the extended wear life.

Aluminum extrusion in blade base holds cleaner snugly to backbone.

Durable and rugged Martin® Spring Tensioner XHD maintains cleaning pressure.

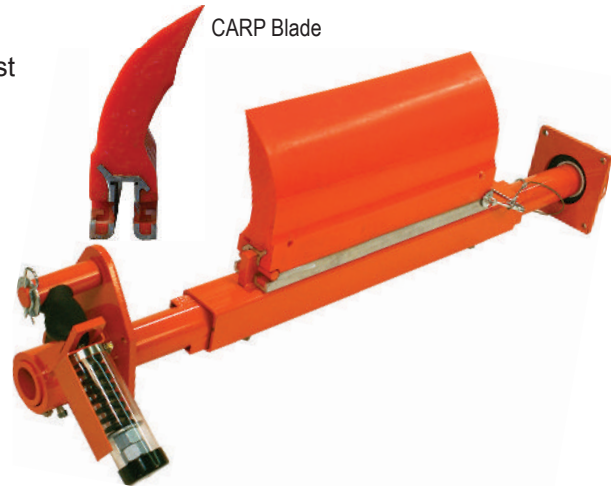

MARTIN® QC1™ CLEANER HD AND XHD STS

Designed to allow for all service to take place safely outside of the chute, eliminating the need for confined space permit while preventing injuries and keeping workers from harm's way. The one-pin blade replacement makes service fast and easy. Patented "CARP" design maintains cleaning performance through all stages of blade life. Economical cleaner and tensioner system combines effective cleaning, durable life and low-maintenance requirements. Available with either a Martin® Spring Tensioner HD STS or a Martin® Air Tensioner HD STS to maintain proper cleaning pressure while minimizing the need for adjustment.



Also available with air tensioner



MARTIN® QC1™ CLEANER XHD

Engineered to preserve the cleaning edge from high belt speeds and multiple splices.

Patented “CARP” blade design maintains cleaning performance through all stages of blade life.

An aluminum extrusion in the belt cleaner bladebase holds the cleaner snugly to the backbone.



MARTIN® SHD 600 & 1200 SERIES CLEANERS

Structural steel means no more bent mainframes, even with high tonnages and large lumps.

Massive urethane blades provide up to 12 inches (305 mm) of wear life.

Martin® SHD Cleaner and tensioner are designed together for effective cleaning and reduced service requirements.

Patented “CARP” blade design maintains cleaning performance through all stages of blade life.



SECONDARY CLEANERS

MARTIN® SECONDARY CLEANERS

Installed at the point where the belt is leaving the discharge pulley, secondary cleaners remove residual fines that remain on the belt past the primary cleaner. Its location is typically close enough to the material trajectory that the cleanings will return to the main material stream.

Additional tertiary cleaners can be installed to provide final cleaning. These cleaners can be the same model as the secondary cleaner, or of a different design to allow efficient cleaning and maintenance within the available space.

As these cleaners are typically installed away from the pulley, they should be placed at or near a point where the belt is against a roller. Firm support prevents the cleaning pressure from raising the belt line and reducing cleaning efficiency.

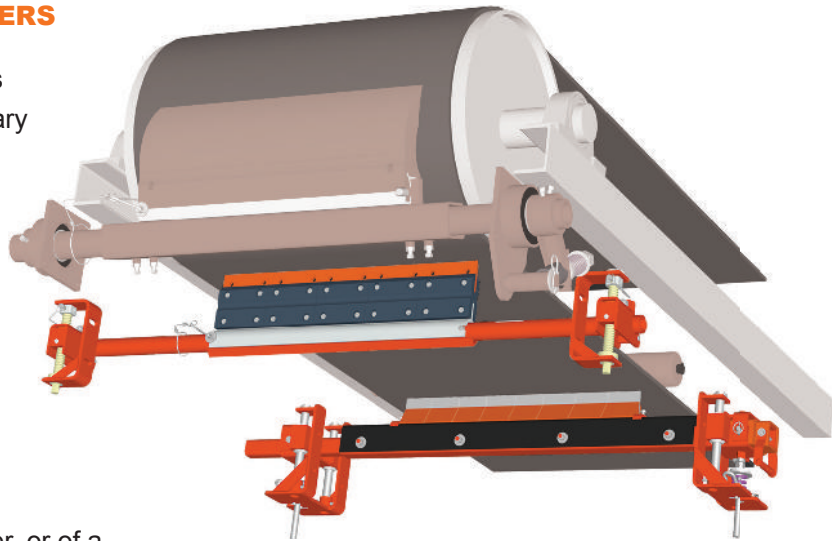

SELECTION GUIDE

1. Check your conveyor's **belt speed** against the specifications listed for the secondary cleaners in the table below.
2. If your belt features multiple mechanical splices, or a mechanical splice in poor condition, avoid using tungsten carbide blades as rapid wear or damage to both the blade and splice may result.

APPLICATION SPECIFICATIONS

Belt Cleaner	Max Belt Speed fpm (m/sec)	Handles Reversing Belts & Rollback	Available Blade Materials				
			Mild Steel	Stainless Steel	Tungsten Carbide	Urethane	SS / TC stainless steel holder with tungsten carbide inserts
CleanScrape® Secondary	900 (3.5)						X
DT2S Reversing Cleaner	900 (3.5)	X	X	X	X	X	X
SQC2S™ Cleaner	1000 (5.1)	X	X	X	X	X	X
SQC2 RM™ Cleaner	800 (5.1)	X			X		X
SQC2S™ Cleaner STS	1000 (5.1)	X	X	X	X	X	X
DT2H Inline Cleaner XHD	1200 (6.1)	X			X	X	X

Please note: Stainless steel mainframes and tensioners are available for corrosive environments.



CLEANSRAPE® SECONDARY CLEANER

The CleanScrape® Secondary Cleaner is an all stainless steel assembly featuring independent 6-inch wide blades with carbide tips.

Each tip is supported on spring-loaded arms at both ends. The load springs allow independent blade rotation back and forward as well as up and down.

This range of motion provides equal load pressure across each blade, absorbs obstructions, conforms to ever-changing belt undulations, and is able to arc safely in the event of reversing belt direction or belt rollback.

Requiring minimal ongoing maintenance, CleanScrape® Secondary Cleaner needs only one tensioner adjustment—EVER.



MARTIN® DT2S REVERSING CLEANER

Slide-in/slide-out belt cleaner blade cartridge allows quick and easy blade service that minimizes conveyor downtime. Even when the cleaner is encrusted with material, one-half of the split frame can be removed to allow blade change.

Effective belt cleaning reduces plant cleanup chores and prolongs life of conveying equipment.

Can be installed on conveyors that roll back or run in two directions with proper blade selection.

Lean profile minimizes space requirements, allows installation in spaces as narrow as seven inches (178 mm).



MARTIN® DT2H REVERSING CLEANER XHD

Reduces plant cleanup chores and prolongs the life of conveyor components.

Mandrel allows quick-and-easy belt cleaner blade replacement to increase conveyor availability.

Individual belt cleaner blade segments slide into sturdy track-forming cartridge. This cartridge slides over stainless steel mainframe into cleaning position. The split-track cartridge design allows simple belt cleaner blade removal even with material accumulation.

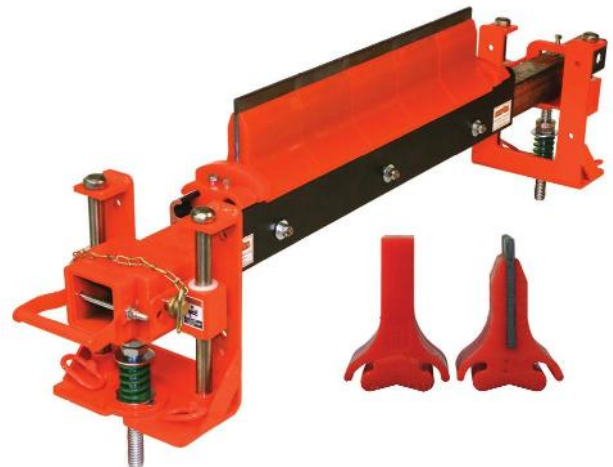

MARTIN® QC™ #2

One-pin blade replacement makes belt cleaner blade replacement an easy, one-minute, no-tool operation. Unique teardrop blade profile absorb radial stress while spring tensioners provide linear relief. Individual 76-mm (3-inch) wide blades independently conform to the profi



 Product can be powered by Martin® Roll Gen™ System. * With Air Tensioner only.

MARTIN® SQC2S™ CLEANER

Rugged construction withstands harsh applications like high-speed belts and high-tonnage loads. Compact design allows installation in close quarters; narrow profile resists material buildup. Blade replacement is simple: remove the pin, slide the cartridge out, service and return.

SQC2S™ Cleaner cartridge comes with different blade options to suit your application:

RUBBER BUFFER

Patented rubber buffers maintain cleaning pressure while deflecting to allow for splices to pass and for reversal of belt direction without damage.

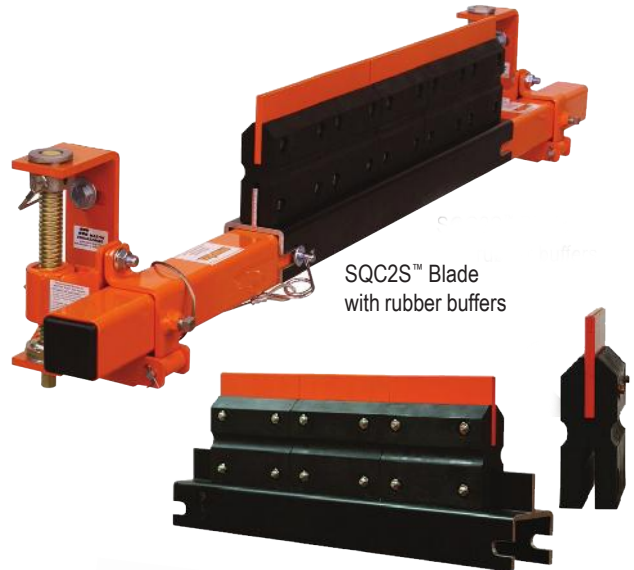

MARTIN® SQC2™ RM BLADES

Rugged construction withstands harsh applications like high-speed belts and high-tonnage loads. Reduced height design allows installation in confined space; narrow profile resists material buildup. Blade replacement is simple: remove the pin, slide the cartridge out, service and return.

SQC2™ RM Cleaner cartridge comes with different blade options to suit your application.



SAF BLADES

Light "touch" of resilient three-inch wide (75 mm), urethane blades reduces risk of damage, even on belts with multiple fasteners, rips or longitudinal splices or rollback. As cleaning edge wears, the urethane blades self-adjust to maintain effective cleaning. Cartridge mounting provides easy removal of blades from mainframe. Pry out worn blades with a screwdriver and snap new blades into place.



CHEVRON BLADES

Rubber or urethane chevron blades effectively remove carryback while gently stepping over ribs, chevrons, and cleats.

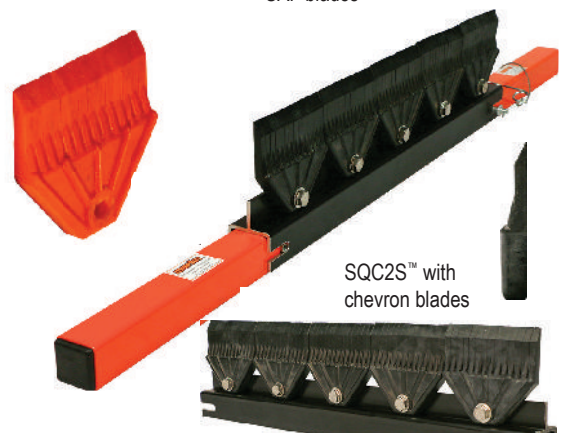

MARTIN® O2 CLEANER

“Paint-scraper” cleaning angle provides maximum removal of carryback and tungsten carbide blade tips provide effective and long-lasting cleaning.

Blade shield allows removed material to slide off without buildup while blade holder flexes to allow tip deflection in direction of belt travel for splice passage.



SQC2S™ CLEANER STS

Designed for safety, this cleaner helps prevent injuries and keep workers from harm’s way during service. This safe-to-service cleaner allows for all service to take place from one side of the conveyor, avoiding the need for confined space entry. Blade replacement/maintenance is quick and easy:

- Disengage tensioner
- Pull blade cartridge outside of the conveyor
- Remove quick release pin & blade cartridge
- Replace blade
- Push cartridge back into position
- Engage the tensioner

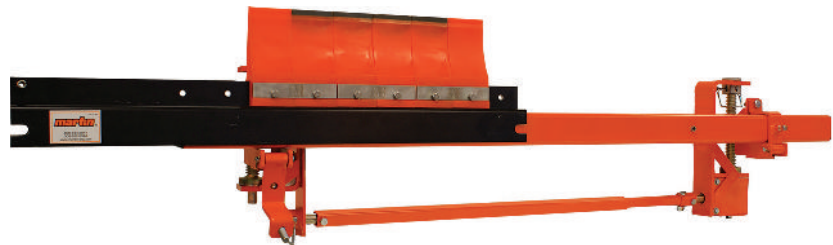

Available with any SQC2S cartridge.

PRESSURE ROLLER AND BRACKETS

The Martin® Pressure Roller Bracket stabilizes the conveyor belt, providing proper pressure for multiple conveyor belt scraper installations or where space limitations prevent installation on head pulley.

Compatible with DH2, SQC2, QC2, SAF, H2O and Reversing Cleaners.

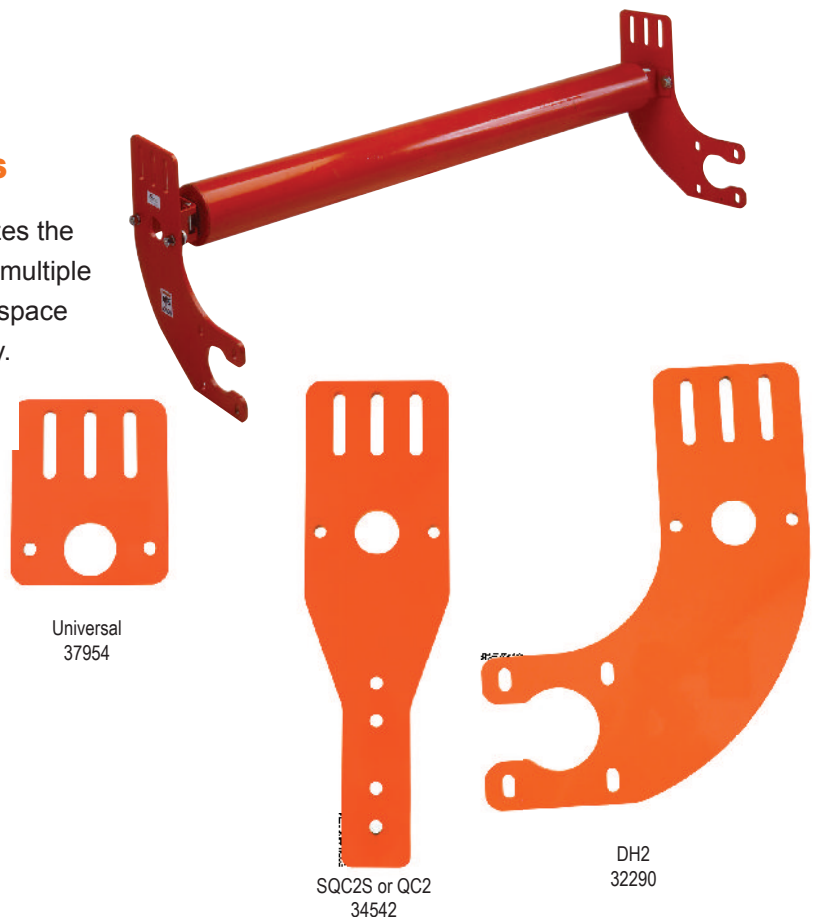

Universal
37954

SQC2S or QC2
34542

DH2
32290



Product can be powered by **Martin® Roll Gen™ System**. * With Air Tensioner only.

SPECIALTY CLEANERS

MARTIN® FOOD GRADE CLEANER

Mounts on the face of the head pulley to reclaim material into the product stream.

Engineered to fit the conveyor specifications and belt cleaning requirements of the food processing and packaging industries.

Modular belt cleaner blades on stainless steel mainframes. Supplied with internal spring tensioner.



MARTIN® BRUSH CLEANER

One or two-horsepower motor (depending on belt width) turns brush against belt motion.

Spiral Brush Cleaner uses 0.38 inch (0.96 mm) polypropylene bristles wrapped in a spiral around the hub.

Strip Brush Cleaner uses 12 brush strips that sheds even moist material that would plug other brushes. Strips are made with 0.40 inch (1 mm) polypropylene bristles.



MARTIN® HIGH TEMPERATURE CLEANER

All-steel construction allows the Martin® High Temperature Cleaner to withstand high temperatures up to 600°F.

Overlapping stainless steel or tungsten carbide blades on coil spring arms provide effective cleaning.

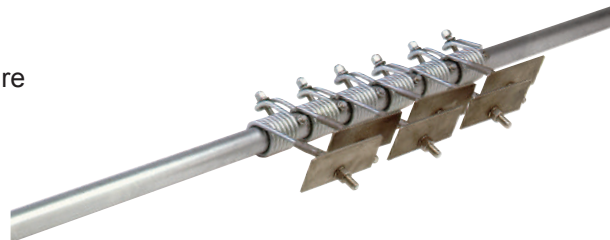

MARTIN® CHEVRON CLEANER

Incorporates arms with blades offset at a 30° angle to allow the edge to ripple over belt cleats.

Use the Chevron Cleaner where stringy material like vines, wire or bark can catch on conventional cleaner arms.



Suited for V-pattern or U-pattern chevrons.



MARTIN® WASHBOX™ CLEANING SYSTEM



Consists of a powder-coated steel enclosure equipped with 3 rollers, 4 spray bars, 4 inspection doors and 2 secondary cleaners.

Rather than “blast” material from the belt, the water softens the carryback.

The installation of a primary cleaner on the face of the head pulley is recommended.

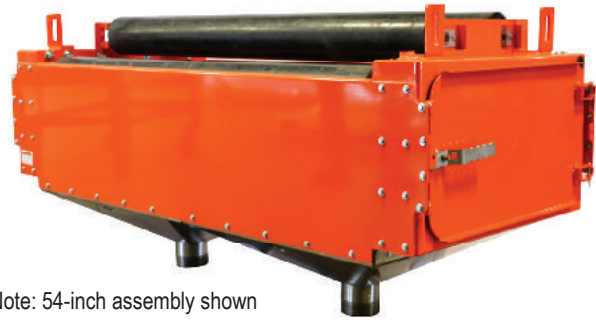

Note: 54-inch assembly shown

TENSIONERS

MARTIN® TWIST™ TENSIONER

The Martin® Twist™ Tensioner can be used on either primary cleaners or secondary cleaners.

Rubber element maintains cleaning pressure with minimal belt cleaner re-tensioning required.

Tensioner allows mechanical splices to pass without damage.

If blades pull through, the tensioner’s coupling rolls over, releasing pressure and reducing the risk of harm to personnel or equipment.

Light aluminum housing and the fully enclosed design keeps the tensioner mechanism clean.



Martin® Twist™ Tensioner

MARTIN® STANDARD AND XHD SPRING TENSIONERS

Spring Tensioners maintain efficient belt cleaning with a rugged coil spring. Several mounting options available.

XHD spring tensioners provide effective cleaning pressure while cushioning splice shock to prevent damage and proficient tensioning for heavy-duty belt cleaners while standing up to tough conditions.

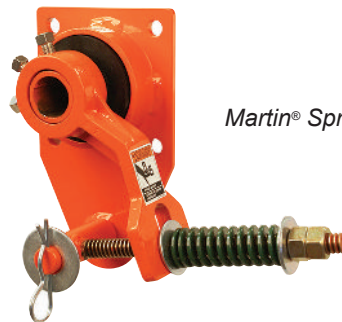

Martin® Spring Tensioner

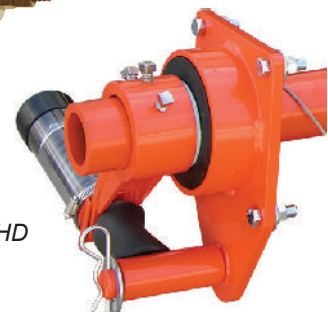

Martin® Spring Tensioner XHD



MARTIN® AIR TENSIONERS

Air Tensioners use the resilience of an air spring to cushion impact. Five models and compatible with control panels and Roll Gen systems. Install in applications from standard-duty to extra-heavy-duty.

Martin® Air Tensioners



Martin® Air Cylinder

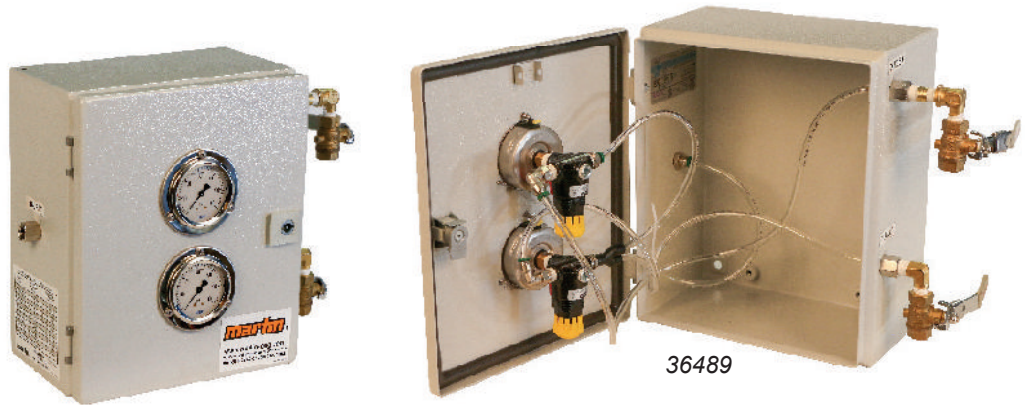
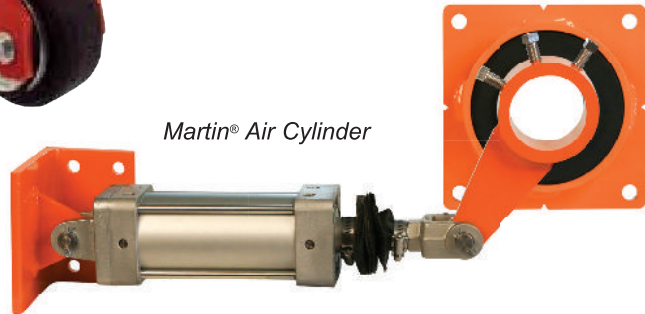

Martin® Air Tensioner Control Panel

MARTIN® INSPECTION DOOR

Latch handle folds down, so door stands only 2.25 inches (57 mm) high. With handle standing, door is 4.1 inches (104 mm) high.

Suitable for service temperatures up to 400° F (204° C) continuous or 450° F (232° C) intermittent.

Also available with integral guard screen.

Round doors available in 3 sizes.



ACCESSORIES

MARTIN® ROLL GEN™ SYSTEM

Self-contained, mini 24-Volt DC power station that generates enough power to run a wide variety of electronic systems:

- Compressor for Air Tensioner
- Activation of Water Supply to Wash Box Belt Cleaning System
- Initiation of Spray Bars
- Firing of an Air Cannon
- LED Lighting
- Reversing Tracker Switching Mechanism
- Many Other Applications...

Martin® Roll Gen™ System* consists of:

- **Martin® Roll Generator (3-year warranty)**

coupled with either:

- **Martin® Roll Gen™ Power Supply**
- **Martin® Roll Gen™ Continuous Power Supply**



* Mounted on Trac-Mount™ Idler Frame. Depending on your existing setup, this may need to be included.

MARTIN® VIBRATING DRIBBLE CHUTE

Keep material accumulations from clogging chute and burying cleaners. Low-friction plastic lining promotes material flow without accumulation.

Rubber-lined bracket transfers vibration to liner without metal fatigue. Electric vibrator provides durable performance.

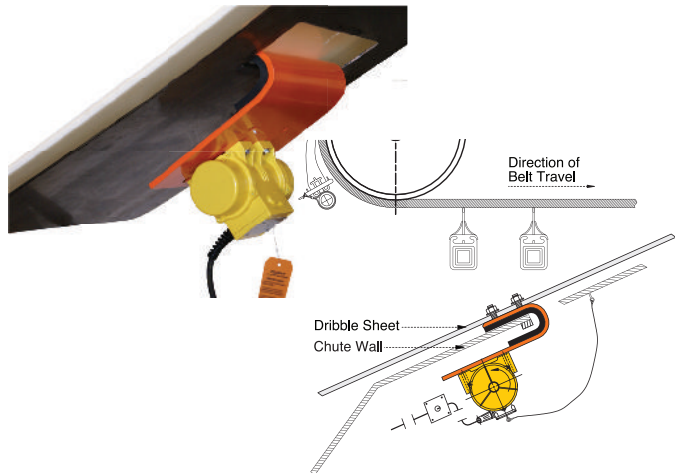

REPLACEMENT BLADES

Martin offers replacement blades for all Martin® belt cleaning systems as well as systems from any manufacturer. Containing 20% more urethane in the wearable area than competitive blades, Martin® blades clean better and last longer.

Features and Benefits

- Effectively eliminate material carryback
- Reduce lost material
- Decrease maintenance hours and expenses
- Fewer blade changes mean less downtime
- Best price per performance of ANY blade on the market
- All Martin® Primary Blades utilize our patented CARP (Constant Angle Radial Pressure) profile, ensuring consistent cleaning across all stages of blade wear and life.

Martin®
QC1™ Cleaner HD
Replacement Blade

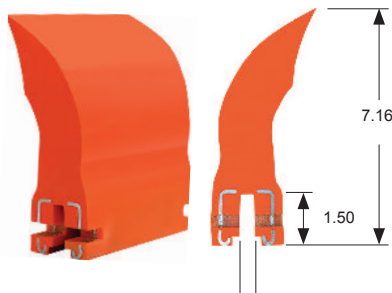

Martin®
PV Cleaner
Replacement Blade

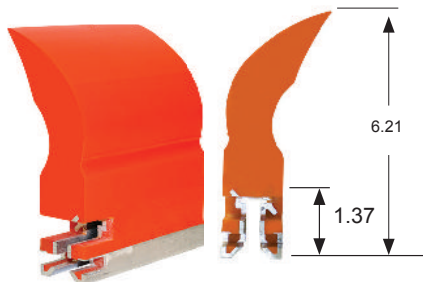

Martin®
XHD Cleaner
Replacement Blade

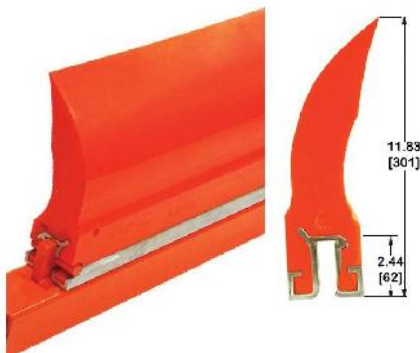

Martin®
SHD Cleaner
Replacement Blade

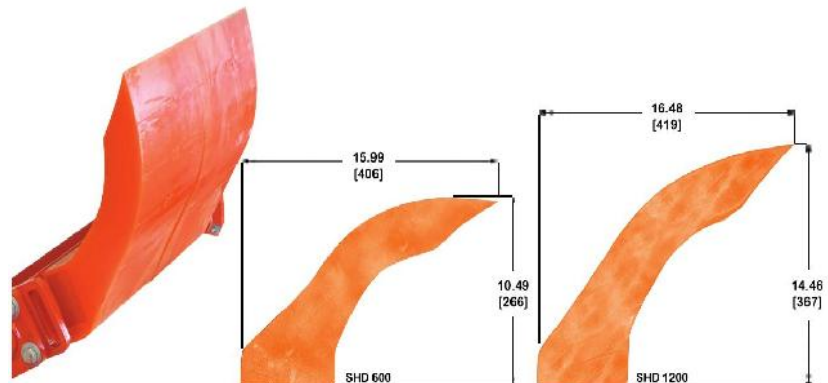

PRIMARY CLEANERS

CLEANSRAPE® PRIMARY

Assembly P/N	C1CXXR
Carbide Selection	X
Technical Data Sheet P/N	L4040
Maximum Belt Speed	1500 fpm
Belt Width	18-120 in.
Pulley Diameter	12-78 in.

MARTIN® PV CLEANER

Assembly P/N	PV1S
Blade P/N	PV-XXXXXXXX
Technical Data Sheet P/N	L3736
Maximum Belt Speed	500 fpm
Maximum Belt Width	72 in.
Pulley Diameter	10-16 in.

MARTIN® QC1™ CLEANER PD

Assembly P/N	38556
Blade P/N	35381
Technical Data Sheet P/N	L3799
Maximum Belt Speed	900 fpm
Maximum Belt Width	84 in.
Pulley Diameter	16-22 in.

MARTIN® QC1™ CLEANER HD

Assembly P/N	36898
Blade P/N	35381
Technical Data Sheet P/N	L3370
Maximum Belt Speed	900 fpm
Maximum Belt Width	96 in.
Pulley Diameter	16-22 in.

MARTIN® QC1™ CLEANER HD MAX

Assembly P/N	38926
Blade P/N	38900
Technical Data Sheet P/N	L3885
Maximum Belt Speed	1200 fpm
Maximum Belt Width	72 in.
Pulley Diameter	24-30 in.

MARTIN® QC1™ CLEANER XHD

Assembly P/N	35899
Blade P/N	35897
Technical Data Sheet P/N	L3799
Maximum Belt Speed	1200 fpm
Maximum Belt Width	120 in.
Pulley Diameter	24-30 in.

MARTIN® QC1™ CLEANER XHD STS

Assembly P/N	STSXHDQC
STS Tensioner	39100
Technical Data Sheet P/N	L3997
Maximum Belt Speed	1200 fpm
Belt Width	24-72 in.
Pulley Diameter	24-30 in.

MARTIN® QC1™ CLEANER HD STS

Assembly P/N	STSHDQC
STS Tensioner	35381
Technical Data Sheet P/N	L4044
Maximum Belt Speed	900 fpm
Maximum Belt Width	72 in.
Pulley Diameter	16-22 in.

MARTIN® SHD 600 & 1200 SERIES CLEANERS*

Assembly P/N	SH1X
600 Series Blade P/N	35568
1200 Series Blade P/N	35569
SHD Turnbuckle Tensioner	35600
SHD Spring-Link Tensioner	35978
Technical Data Sheet P/N	L3439
Maximum Belt Speed	1500 fpm
Maximum Belt Width	120 in.
600 Series Pulley Dia.	30-48 in.
1200 Series Pulley Dia.	48+ in.

SECONDARY CLEANERS

CLEANSRAPE® SECONDARY

Assembly P/N	C2C1S
Technical Data Sheet P/N	L4129
Maximum Belt Speed	900
Belt Width	18-96 in.

MARTIN® DT2S REVERSING CLEANER

Assembly P/N	DT2S
Reversing Blade P/N	31104
Cartridge P/N	DT2SC
Spring Tensioner P/N	37707
Air Tensioner P/N	37707-A
Technical Data Sheet P/N	L3685
Maximum Belt Speed	1000 fpm
Belt Width	24-96 in.

MARTIN® DT2H

REVERSING CLEANER XHD

Assembly P/N	DT2H
Reversing Blade P/N	32494
Cartridge P/N	DT2HC
Spring Tensioner P/N	37806
Air Tensioner P/N	37806-A
Technical Data Sheet P/N	L3690
Maximum Belt Speed	1200 fpm
Belt Width	18-96 in.

MARTIN® SQC2S™ CLEANER

Assembly P/N	SQC2S
SQC2S™ Blade P/N	SC-10002
SAF-2™ Blade P/N	38231
Rubber Buffer	SC10001MR
Cartridge P/N	SQC2SC
Technical Data Sheet P/N	L3686
Maximum Belt Speed	1000 fpm
Belt Width	18-96 in.
Sq. Mainframe Tensioner	3664
Sq. Mainframe Tensioner HD	38664-HD
Far-Side Tension Adjuster	38664-DXX

MARTIN® QC™ #2 CLEANER

Assembly P/N	35700
Technical Data Sheet P/N	L3452-07/08
Blade P/N	35697
Maximum Belt Speed	1000 fpm
Belt Width	18-96 in.

MARTIN® SQC2S™ CLEANER STS

Assembly P/N	STSSQC2S
SQC2S™ Blade Cartridge	SQC2SC
Maximum Belt Speed	1000 fpm
Belt Width	18-96 in.
Far-Side Tension Adjuster	38664-DXX
HD Hanger Mount Assembly	34233-HD

MARTIN® SQC2 RM CLEANER

Assembly P/N	SQC2RM
Technical Data Sheet P/N	L4093
Blade P/N	SQC2RMC
Maximum Belt Speed	800
Belt Width	18-72 in.

MARTIN® O2 CLEANER

Assembly P/N	OR2000
Torsion Mount Tensioner	OR3TMXXXX
Solid Mount Tensioner	OR3SMXXXX
Dual Solid Mount Tensioner	OR-3-DSM
Technical Data Sheet P/N	L3709
Maximum Belt Speed	1200 fpm
Belt Width	30-96 in.

SPECIALTY CLEANERS**MARTIN® FOOD GRADE CLEANER**

Primary Assembly P/N	33035
Internal Spring Tensioner P/N	33036
Secondary Assembly P/N	31369
Food Grade Air Tensioner P/N	31348
Food Grade Hub Mount Tensioner P/N	31368
Technical Data Sheet P/N	L3370-08
Maximum Belt Speed	350 fpm
Belt Width	4-48 in.

MARTIN® CHEVRON CLEANER

Torsion Arm Assembly P/N	36881
Inline Assembly P/N	33705
Technical Data Sheet P/N	L3370-11
Maximum Belt Speed	500 fpm
Belt Width	18-96 in.

MARTIN® BRUSH CLEANER

Strip Assembly P/N	35331
Spiral Brush Assembly P/N	32875
Spiral Polypropylene Brush P/N	28898
Spiral Nylon Brush P/N	28560
Strip Brush with Hubs P/N	35327
Brush Strips (Set of 12) P/N	35329
Technical Data Sheet P/N	L3431
Maximum Belt Speed	—
Belt Width	18-72 in.

MARTIN® HIGH TEMPERATURE CLEANER

Assembly P/N	21042
Tungsten Carbide Blade P/N	27924
Stainless Steel Blade P/N	16960
Technical Data Sheet P/N	L3370-12
Maximum Belt Speed	750 fpm
Belt Width	18-96 in.
Maximum Service Temperature	600° F

MARTIN® WASHBOX CLEANING SYSTEM

Dual Belt Cleaner Assembly P/N	WBPXX
Single Belt Cleaner Assembly P/N	WBSCPXX
Technical Data Sheet P/N	L3780
Maximum Belt Speed	750 fpm
Belt Width	18-84 in.



TENSIONERS

MARTIN® TWIST™ TENSIONER

Single Tensioner P/N	38850-0X
Dual Tensioner P/N	38850-2X
Technical Data Sheet P/N	L3839

MARTIN® REVERSING MOUNT SPRING TENSIONER

Reversing Mount Tensioner P/N	33599
Reversing Cleaner Z Bracket P/N	31158-01
Reversing Hanger Mount Assembly P/N	33288
Belt Width	18-96 in.
Technical Data Sheet P/N	L3370-16

MARTIN® SPRING TENSIONER STANDARD

Tensioner P/N	38180
Belt Width	18-48 in.
Dual Tensioner P/N	38180-2
Belt Width	54-96 in.
Technical Data Sheet P/N	L3370-16

MARTIN® SPRING TENSIONER XHD

Tensioner P/N	38003
Belt Width	18-48 in.
Dual Tensioner P/N	38003-2
Belt Width	54+ in.
Technical Data Sheet P/N	L3370-16

MARTIN® ADJUSTABLE L BRACKET SPRING TENSIONER

Tensioner P/N	31291-SM
Belt Width	18-54 in.
Technical Data Sheet P/N	L3370-16

MARTIN® AIR TENSIONERS

Control Box P/N	36489
XHD Air Tensioner P/N	32135
Std./HD Air Tensioner P/N	37843
Std./HD Air Control Kit P/N	31772-AS
Control Panel w/CO ₂ P/N	38491-2
XHD Air Control Kit P/N	32181

MARTIN® MOUNTING BRACKETS

L Bracket P/N	33706
Flange Mount Bracket P/N	30537
Hanger Mount Assembly P/N	27382
Reversing Hanger Mount Assembly P/N	33288
Heavy Duty Hanger Mount Assembly P/N	34233-HD
Technical Data Sheet P/N	L3370-16

ACCESSORIES

MARTIN® INSPECTION DOORS

Steel Door P/N	CYA-XXXX
Rubber Door P/N	CYAR-XXXX
Extended-Height Steel Door P/N	CYAE-XXXX
Round Steel Door P/N	CYARD-XXXX
Technical Data Sheet P/N	L3432

MARTIN® ROLL GEN™ SYSTEM

Roll Generator	RG1-010-XXPX
Roll Gen™ Power Supply	39413
Roll Gen™ Continuous Power Supply	contact for specs

MARTIN® PRESSURE ROLLER BRACKET

Brackets Pair w/Roller for DH2 P/N	32290-XXXX
Brackets Pair w/o Roller P/N	32290-XX
Bracket Assembly for SAF2™ & SQC2S™ P/N	34542-XX
Bracket Assembly for O2, H2O & DT2 P/N	37954-XXXX
Technical Data Sheet P/N	L3370-15

MARTIN® VIBRATING DRIBBLE CHUTE

Vibrating Dribble Chute P/N	31546
w/Overload Protection P/N	31546-OL
Dribble Sheet Liner P/N	31494XXXXXX
Technical Data Sheet P/N	L3370-14



GLOBAL LOCATIONS

 UNITED STATES	 INDIA	
 AUSTRALIA	 INDONESIA	 SPAIN
 BRAZIL	 ITALY	 SOUTH AFRICA
 CHINA	 MEXICO	 TURKEY
 FRANCE	 PERU	 UNITED KINGDOM
 GERMANY		

Authorized representatives in over 32 additional countries

PT MARTIN SUPRA ENGINEERING (MARTIN ENGINEERING, INDONESIA)

Pergudangan Bandara Mas Blok A8 No. 9
Tangerang 15127 Indonesia

Phone : +62 21 55912842/3
Fax : +62 21 55912840
E-mail : info@martinsupra.co.id
Website: www.martin-eng.co.id

Part No. L3651-04/24IN