

PART NO.	BELT WIDTH	DIM "A" FRAME LENGTH	DIM "B" BLADE WIDTH
SQC2-18X12XXXXX	18.00 [400-500]	48.94 [1243]	11.81 [300]
SQC2-18X18XXXXX	18.00 [400-500]	48.94 [1243]	17.72 [450]
SQC2-24X18XXXXX	24.00 [500-650]	54.85 [1393]	17.72 [450]
SQC2-24X24XXXXX	24.00 [500-650]	54.85 [1393]	23.62 [600]
SQC2-30X24XXXXX	30.00 [350-800]	60.75 [1543]	23.62 [600]
SQC2-30X30XXXXX	30.00 [350-800]	60.75 [1543]	29.53 [750]
SQC2-36X30XXXXX	36.00 [800-1000]	66.66 [1693]	29.53 [750]
SQC2-36X35XXXXX	36.00 [800-1000]	66.66 [1693]	35.43 [900]
SQC2-42X35XXXXX	42.00 [100-1200]	72.56 [1843]	35.43 [900]
SQC2-42X41XXXXX	42.00 [100-1200]	72.56 [1843]	41.34 [1050]
SQC2-48X41XXXXX	48.00 [1200-1400]	78.47 [1993]	41.34 [1050]
SQC2-48X47XXXXX	48.00 [1200-1400]	78.47 [1993]	47.24 [1200]
SQC2-54X47XXXXX	54.00 [1400-1600]	84.37 [2143]	47.24 [1200]
SQC2-54X53XXXXX	54.00 [1400-1600]	84.37 [2143]	53.15 [1350]
SQC2-60X53XXXXX	60.00 [1600-1800]	90.28 [2293]	53.15 [1350]
SQC2-60X59XXXXX	60.00 [1600-1800]	90.28 [2293]	59.06 [1500]
SQC2-66X59XXXXX	66.00 [1600-1800]	96.19 [2443]	59.06 [1500]
SQC2-66X65XXXXX	66.00 [1600-1800]	96.19 [2443]	64.96 [1650]
SQC2-72X65XXXXX	72.00 [1800-1900]	102.09 [2593]	64.96 [1650]
SQC2-72X71XXXXX	72.00 [1800-1900]	102.09 [2593]	70.87 [1800]
SQC2-78X71XXXXX	78.00 [1900-2000]	108.00 [2743]	70.87 [1800]
SQC2-78X77XXXXX	78.00 [1900-2000]	108.00 [2743]	76.77 [1950]
SQC2-84X77XXXXX	84.00 [2000-2100]	113.90 [2893]	76.77 [1950]
SQC2-84X83XXXXX	84.00 [2000-2100]	113.90 [2893]	82.68 [2100]
SQC2-90X83XXXXX	90.00 [2100-2200]	119.81 [3043]	82.68 [2100]
SQC2-90X89XXXXX	90.00 [2100-2200]	119.81 [3043]	88.58 [2250]
SQC2-96X89XXXXX	96.00 [2200-2400]	125.72 [3193]	88.58 [2250]

BLADE CHART		
PART NO.	COLOR	GENERAL APPLICATION
SQC2-XXGXXXXXXX	ORANGE	ACID RESISTANT BELT WITH CLIPS
SQC2-XXHXXXXXXX	ORANGE	ACID RESISTANT
SQC2-XXRXXXXXXX	ORANGE	GENERAL CONDITIONS REV BELT WITH CLIPS

ITEM	QTY.	DESCRIPTION	PART NUMBER
1	1	MARTIN®SQC2™ CLNR & TENS ASM	SEE CHART
2	1	DUST TIGHT COVER ASM	38014-SQC

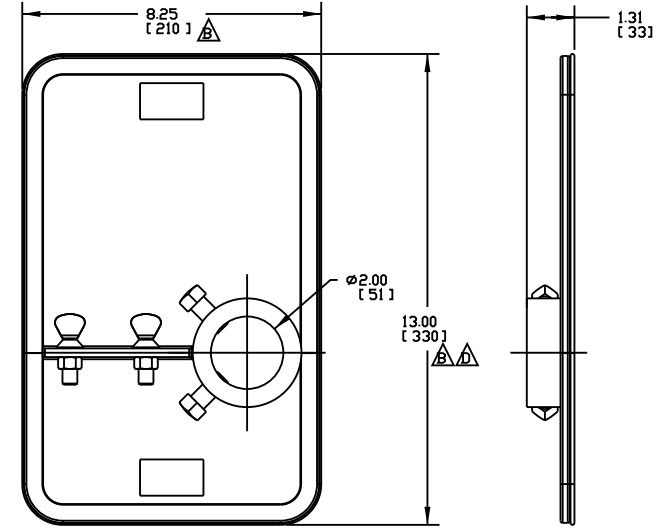
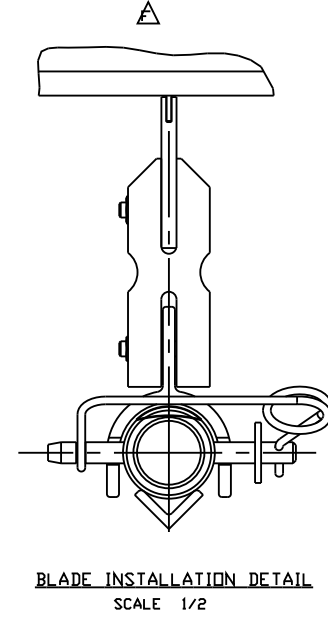
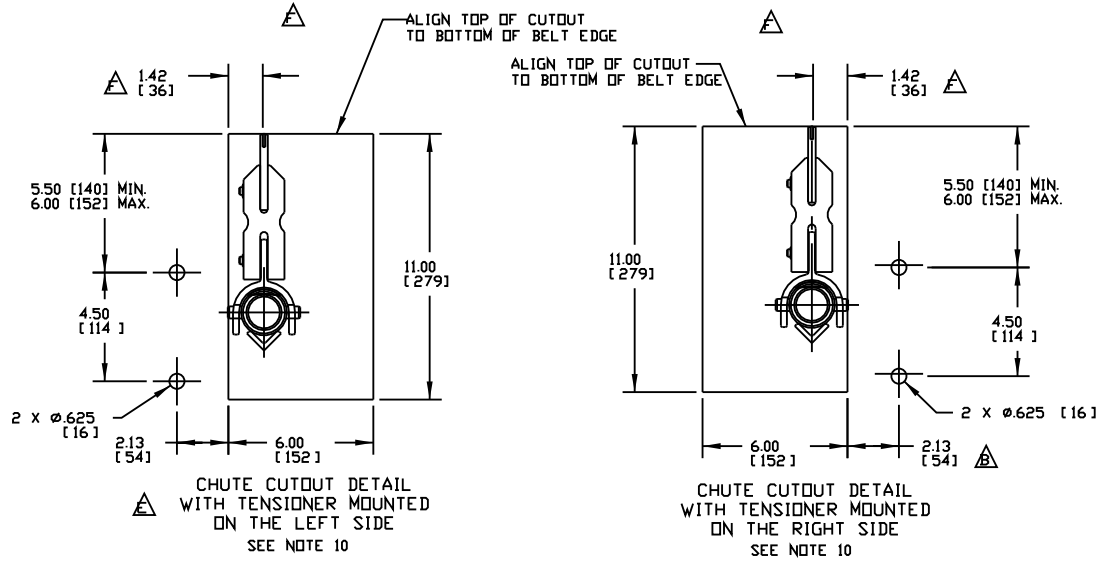

- NOTES:
- 1) ALL DIMENSIONS ARE GIVEN IN INCHES (MM).
 - 2) ALL DIMENSIONS ARE FOR REFERENCE ONLY.
 - 3) FOR EASE OF ACCESSIBILITY AND MAINTENANCE MARTIN ENGINEERING RECOMMENDS BOLTING CLEANER TO EXISTING STRUCTURE WHEN APPLICABLE.
 - 4) DUE TO STRUCTURAL TOLERANCES IN THE FIELD, DIMENSIONS AND LOCATIONS MAY VARY.
 - 5) WHERE EXTREME AND UNUSUAL CONDITIONS EXIST, OR SPECIAL MAINFRAME LENGTHS ARE REQUIRED, CONTACT MARTIN ENGINEERING.
 - 6) CUSTOMER MAY HAVE TO MODIFY STRUCTURE TO PROPERLY INSTALL CLEANER.
 - 7) REFER TO OPERATOR'S MANUAL (M3682) FOR ADDITIONAL AND OPTIONAL INSTALLATION INSTRUCTIONS.
 - 8) MARTIN ENGINEERING RECOMMENDS POSITIONING OF AN IDLER FOR PROPER BACKING SUPPORT OF THE SCORPID BLADE IF NOT LOCATED ON THE HEAD PULLEY.

- NOTES:
- 9) MAINFRAME IS SUPPLIED LONGER THAN REQUIRED, FIELD CUT TO DESIRED LENGTH.
 - 10) LOCATE AND DRILL HOLES FOR TENSIONER BEFORE LOCATING ACCESS WINDOW. NOTE TENSIONER LT/RT MOUNTING DIRECTION.
 - 11) IN THE CLEANER PART NUMBER THE SQC2 INDICATES A MARTIN SQC2 QUICK-CHANGE SECONDARY CLEANER. THE NEXT TWO DIGITS INDICATE THE BELT WIDTH, THE NEXT DIGIT INDICATES THE BLADE TYPE (SEE BLADE CHART), THE NEXT TWO DIGITS INDICATE THE BLADE CLEANING WIDTH, THE NEXT TWO DIGITS INDICATE THE BLADE BUFFER TYPE (MR FOR STD RUBBER, FR FOR FLAME RETARDANT RUBBER), THE NEXT DIGIT INDICATES THE MAINFRAME OPTIONS (P FOR STD PAINTED, S FOR STAINLESS STEEL), THE NEXT DIGIT INDICATES IF A TENSIONER IS INCLUDED (T IS WITH TENSIONER, O IS WITHOUT), THE LAST DIGIT IS FOR ADDITIONAL OPTIONS (D = DUST TIGHT STEEL COVER DOOR).

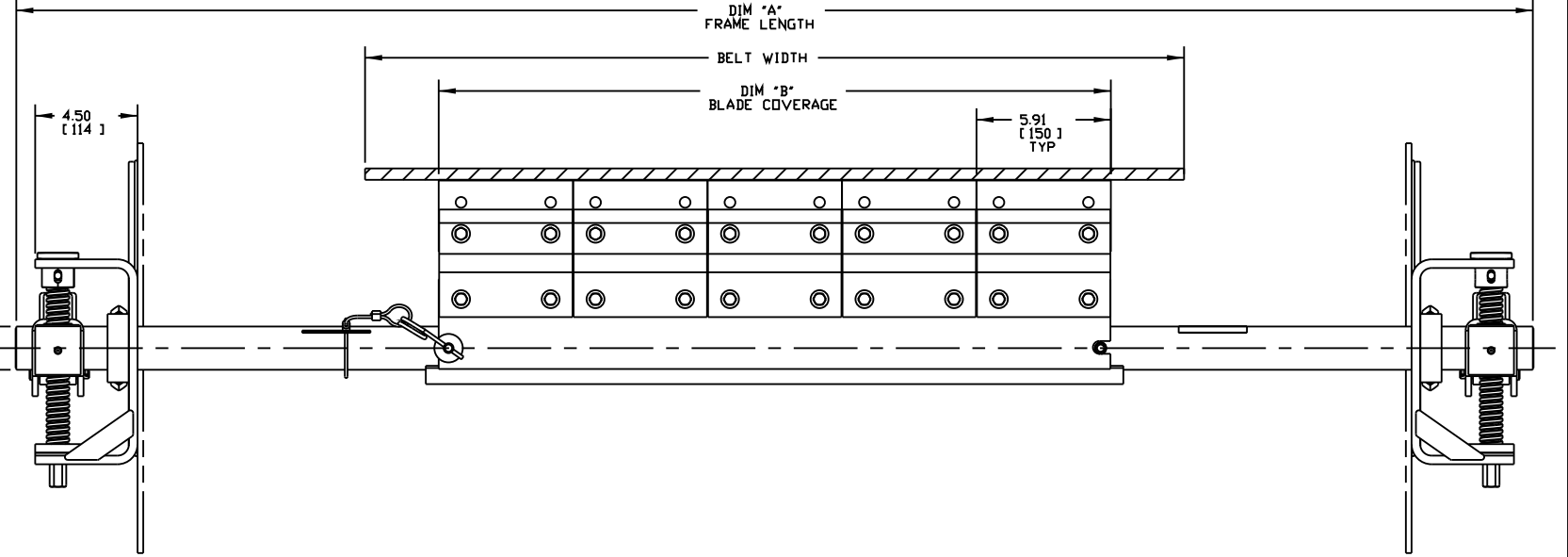
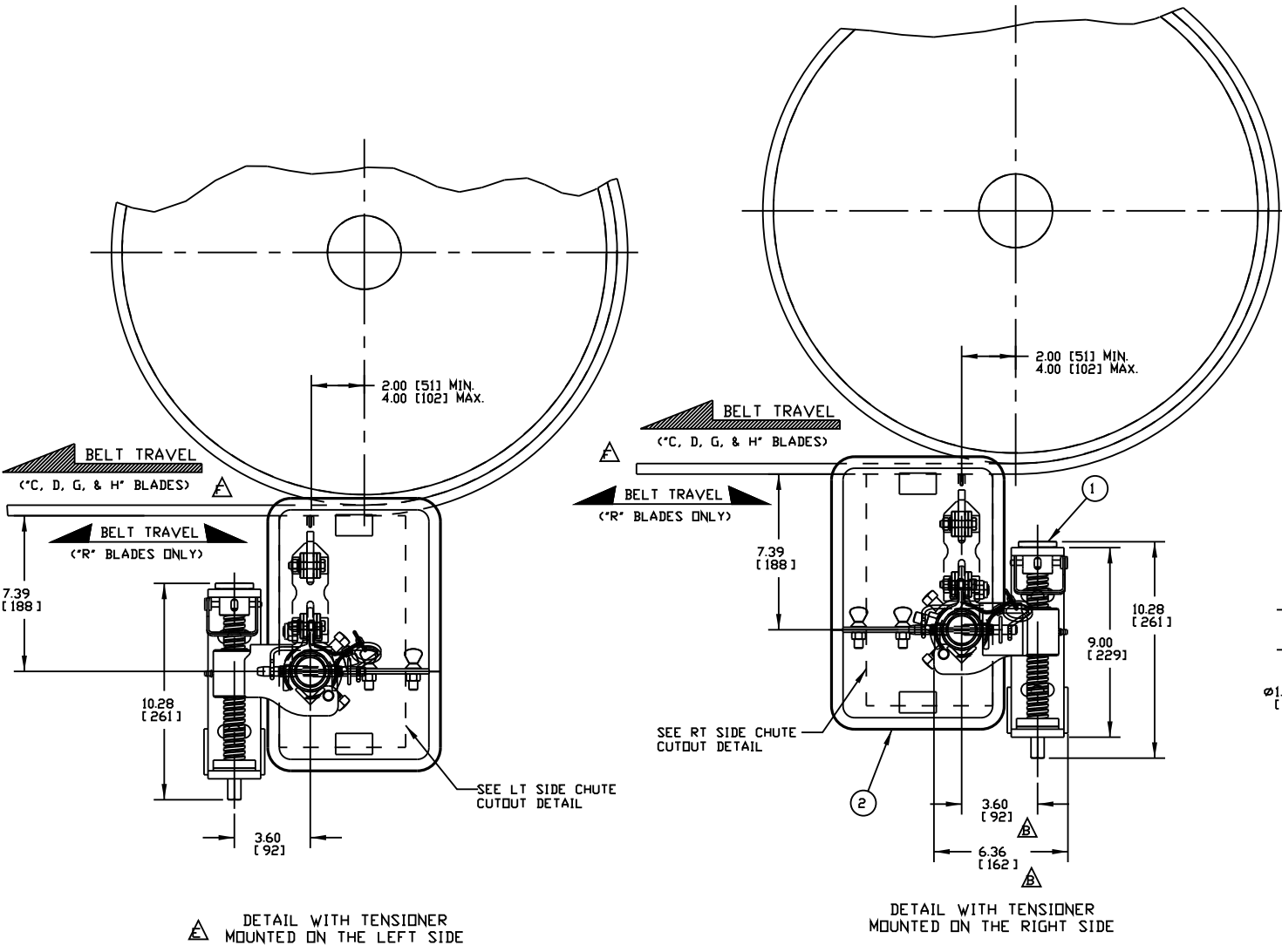

NO.	REVISION	DESCRIPTION	ECN	DATE	BY
G	RMVD P/N SQC2-XXCXXXXXX & -XXDXXXXXX FROM THE BLADE CHART	12810	09/22/10	MJB	
F	CHG DIM FROM 1.63 TO 1.42, FROM 1.31 TO 1.42 / RMVD BELT DIRECTION ARROW, ADDED BI-DIRECTIONAL ARROW / REPAIRED BLADE TIP PROFILE (M00725)	12594	12/01/09	RND	
E	ADDED LT SIDE TENSIONER MOUNTING DETAILS (M00774)	12594	05/27/09	RND	
D	CHG DIM FROM 16.50 TO 13.00/ADDED DIM 1.31	12594	03/12/09	MJB	
C	IDN P/N SQC2-XXCXXXXXX & -XXDXXXXXX CHG COLOR IN CHART FROM WHITE TO ORANGE	12546	01/19/09	MJB	
B	CHG DIM FROM 5.94 TO 3.68 & 8.76 TO 6.36 & 2.94 TO 2.13/ADDED DIM 8.25 & 16.50	11813	04/16/07	MJB	
A	RMVD P/N SQC2-XXAXXXXXX, -XXBXXXXXX, -XXEXXXXXX, -XXFXXXXXX, -XXJXXXXXX, -XXKXXXXXX, -XXLXXXXXX, -XXMXXXXXX FROM THE BLADE CHART	11780	10/05/06	MJB	

MARTIN ENGINEERING		NEPONSET ILLINOIS USA	
TITLE	SALES DRAWING	DATE	SCALE
MARTIN® SQC2™ SECONDARY BELT CLEANER DUST TIGHT COVER DOOR		08/02/06	1/4
APPROVED JMM	DATE 08/03/06	CHECKED MJB	DATE 08/02/06

Copyright 2010 Martin Engineering. All rights reserved. Covered by U.S. and Foreign patents pending and issued. ® and ™ indicate trademarks of Martin Engineering.

M00669 S-SQC2-S35799-S

