

martin[®]

Martin[®] ***MSVX*** ***Screen Vibrators***

[Go to Martin[®] MSVX Screen Vibrators web page](#)



Operator's Manual
M3920

Important

MARTIN ENGINEERING HEREBY DISCLAIMS ANY LIABILITY FOR: DAMAGE DUE TO CONTAMINATION OF THE MATERIAL; USER'S FAILURE TO INSPECT, MAINTAIN AND TAKE REASONABLE CARE OF THE EQUIPMENT; INJURIES OR DAMAGE RESULTING FROM USE OR APPLICATION OF THIS PRODUCT CONTRARY TO INSTRUCTIONS AND SPECIFICATIONS CONTAINED HEREIN. MARTIN ENGINEERING'S LIABILITY SHALL BE LIMITED TO REPAIR OR REPLACEMENT OF EQUIPMENT SHOWN TO BE DEFECTIVE.

Observe all safety rules given herein along with owner and Government standards and regulations. Know and understand lockout/tagout procedures as defined by American National Standards Institute (ANSI) z244.1-1982, *American National Standard for Personnel Protection - Lockout/Tagout of Energy Sources - Minimum Safety Requirements* and Occupational Safety and Health Administration (OSHA) Federal Register, Part IV, 29 CFR Part 1910, *Control of Hazardous Energy Source (Lockout/Tagout); Final Rule*.

The following symbols may be used in this manual:



Danger: Immediate hazards that will result in severe personal injury or death.



Warning: Hazards or unsafe practices that could result in personal injury.



Caution: Hazards or unsafe practices that could result in product or property damages.



Important: Instructions that must be followed to ensure proper installation/operation of equipment.



Note: General statements to assist the reader.

Table of Contents

Section	Page
Introduction	1
General	1
References	1
Safety	1
Materials required	1
Storage	1
Before Installing Vibrator	2
Installing Vibrator	3
Mounting vibrator onto screen	3
Nut and cap screw torque	4
Markings on Vibrators	5
Connecting power to vibrator	6
Installing overload, short-circuit and ground-fault protection	8
Adjusting eccentric weights	8
After Installing Vibrator	10
Checking shaft rotation	10
Initial start-up/checking line current	11
Variable frequency inverter	12
Maintenance	13
Lubricating vibrator	13
Repairing screen vibrator and replacing bearings	14
Inspecting vibrator	14
Part Numbers	15
Dimensions	25

List of Figures

Figure	Title	Page
1	Mounting Bolt Tightening Sequence	3
2	Markings on MSVX Vibrators	5
3	Wiring Diagrams	6
4	Installing Wire Connector	7
5	Vibrator Weight Settings	9
6	One-Vibrator Screen	10
7	Two-Vibrator Screen	11
8	Martin [®] MSVX Screen Vibrator Part Numbers for MSV70X02-X	16
9	Martin [®] MSVX Screen Vibrator Part Numbers for MSVX170X04 and MSVX175X04	18
10	Martin [®] MSVX Screen Vibrator Part Numbers for MSVX190X04	22
11	Martin [®] MSVX Screen Vibrator Dimensions, MSVX170X04 and MSVX175X04	25
12	Martin [®] MSVX Screen Vibrator Dimensions, MSVX190X04	26

List of Tables

Table	Title	Page
I	Vibrator Nut and Cap Screw Torque Requirements	4
II	Vibrator Weight Settings	9
III	Martin [®] MSVX Screen Vibrator Part Numbers for MSVX170X04 and MSVX175X04	20
IV	Martin [®] MSVX Screen Vibrator Part Numbers for MSVX190X04	24

General

Martin® MSVX Explosion-Proof Electric Vibrators are designed and manufactured to ensure the best performance and reliability in severe-duty applications. The screen vibrator has an ambient temperature rating including mounting surface temperature of -4 to 131°F (-20 to 55°C). If operating the screen vibrator in environments beyond these temperatures, call Martin Engineering, as the vibrator may require rating reduction, more frequent lubrication, or lubrication substitution.

References

The following documents are referenced in this manual:

- *The National Electrical Code (NEC)*, National Fire Protection Association, 1 Batterymarch Park, P.O. Box 9101, Quincy MA 02269-9101.
- American National Standards Institute (ANSI) z244.1-1982, *American National Standard for Personnel Protection - Lockout/Tagout of Energy Sources - Minimum Safety Requirements*, American National Standards Institute, Inc., 1430 Broadway, New York, NY 10018.
- Code of Federal Regulation (CFR) 29, Part 1910, *Control of Hazardous Energy Source (Lockout/Tagout); Final Rule*, Department of Labor, Occupational Safety and Health Administration (OSHA), 32nd Floor, Room 3244, 230 South Dearborn Street, Chicago, IL 60604.
- CFR 29, Part 1910.15, *Occupational Noise Exposure*, Department of Labor, OSHA, 32nd Floor, Room 3244, 230 South Dearborn Street, Chicago, IL 60604.

Safety

All safety rules defined in the above documents and all owner/employer safety rules must be strictly followed when working on the vibrator.

Materials required

In addition to standard hand tools, the following materials are required to install this equipment:

- Screen Vibrator Mount Kit, P/N 36468 (Mount Kit included with Screen Vibrator)

Storage

Store vibrator in an ambient temperature not less than 41°F (5°C) with a relative humidity not more than 60%. If the vibrator has been stored for 2 or more years, relubricate before using (see “Lubricating Vibrator”).

Before Installing Vibrator

IMPORTANT

The delivery service is responsible for damage occurring in transit. Martin Engineering CANNOT enter claims for damages. Contact your transportation agent for more information.

1. Inspect shipping container for damage. If damage has occurred, report damage to delivery service and fill out delivery service's claim form.
2. Remove vibrator from shipping container.
3. If anything is missing, contact Martin Engineering or a representative.



WARNING

Turn off and lock out/tag out all energy sources.

4. Before installing vibrator, turn off and lock out/tag out all energy sources to mounting structure according to ANSI standards (see "References").

WARNING

Gas level or dust content must be tested before using a cutting torch or welding. Using a cutting torch or welding in an area with gas or dust may cause an explosion.

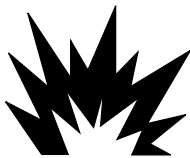

5. If using a cutting torch or welding, test atmosphere for gas level or dust content.
6. Make sure mounting surface is strong and flat, ± 0.01 in. (± 0.25 mm) across vibrator feet. (This will minimize internal stress to vibrator casting when tightening mount bolts. Welding in the area of the mounting surface could affect flatness.)
7. Make sure mounting surface and vibrator are clean and free of debris, paint, and oxidation.

Installing Vibrator

Mounting vibrator onto screen

IMPORTANT

Read entire section before beginning work. This manual provides instructions for installations onto vibrating screens only. For other installations, call Martin Engineering or a representative. Use vibrator mount kit P/N 36468 provided with vibrator.

CAUTION

If installation instructions are not followed, structure and vibrator can be damaged. Abusing or dropping vibrator will accelerate wear and cause bearing damage.

Never weld structure with vibrator mounted and wired. Welding may cause damage to screen vibrator windings and bearings.

Use only new bolts, lock nuts, and hardened flat washers provided with vibrator. Old fasteners can break and cause damage to vibrator or structure.

Do not use split lock washers to install vibrator onto mount. Damage to vibrator could result.

Tighten mounting bolts in sequence shown in Figure 1. If not tightened in order, vibrator casting could be damaged.

1. Position screen vibrator mounting holes over mounting holes on screen frame. Use bolts to hold unit in place. Tighten bolts in order given in Figure 1 to avoid damaging vibrator casting.

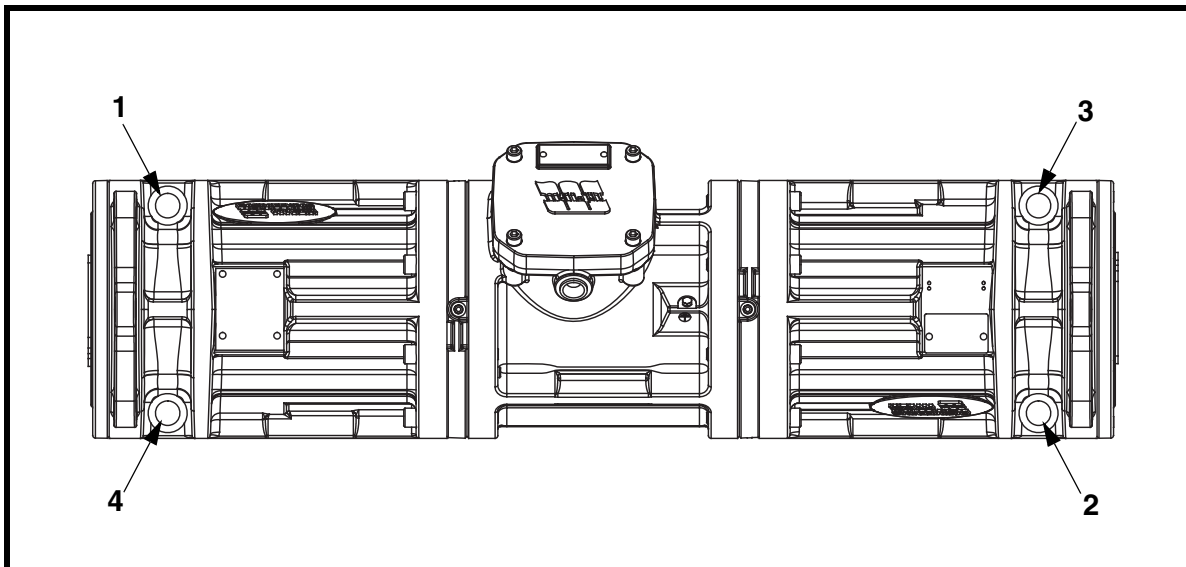

Figure 1. Mounting Bolt Tightening Sequence

2. Position screen vibrators so bolts are free in holes. (There should be no side load on bolts.) While holding unit in position, torque nuts to 455 ft-lbs (63 kgm).



Before checking bolt torque on vibrator, lock out and tag out energy source.

3. After the vibrator has been operated for 10 to 20 minutes, de-energize vibrator, lock out/tag out energy source, and check bolt torque. Tighten if necessary.

Nut and cap screw torque

After removing any nuts or cap screws from vibrator assembly, re-install to the torque values specified in Table I. Any replacement cap screws or nuts must be a minimum grade 8.8.

Table I. Vibrator Nut and Cap Screw Torque Requirements

Cap Screws	ft/lb (kgm)	Terminal Block Nuts	ft/lb (kgm)
M6	7 (1)	M4	0.87 (0.12)
M8	16.5 (2.3)	M5	1.45 (0.20)
M10	28 (3.9)	M6	2.17 (0.30)
M12	58 (8)	M8	4.70 (0.65)
M14	94 (13)	M10	9.80 (1.35)
M16	137 (19)		
M18	195 (27)		
M20	275 (38)		

**Markings on
Vibrators**

The following nameplates are attached to the vibrators:

<div style="border: 1px solid black; padding: 5px;"> <p> 2460 II 2 G Ex db IIB 155°C Gb <small>ITS15 ATEX 18216X CONFORMS TO UL STD 1004-1, UL STD 674; IECEx ETL 15.0011X CERTIFIED TO CSA STD C22.2 NO. 100, 145, 60079-0 AND 60079-1</small> </p> <p style="text-align: center;"> MANUFACTURED BY MARTIN ENGINEERING www.martin-eng.com ELECTRIC INDUSTRIAL VIBRATOR FOR HAZARDOUS LOCATIONS </p> <p> NO. <input style="width: 100%;" type="text"/> CLASS <input type="text" value="I"/> GROUP <input type="text" value="CD"/> OPER. TEMP. T3A $-20^{\circ}\text{C} \leq T_{amb} \leq 55^{\circ}\text{C}$ CLASS I ZONE 1 GROUP II B </p> <p style="text-align: center;">Stainless Nameplate P/N 820005</p> </div>	<div style="border: 1px solid black; padding: 5px;"> <p style="text-align: center;"> </p> <p style="text-align: right;"> MARTIN ENGINEERING ONE MARTIN PLACE NEPONSET, IL 61345-9766 USA (309) 852-2384 WWW.MARTIN-ENG.COM </p> <p style="text-align: center;">MANUFACTURED BY MARTIN ENGINEERING</p> <table style="width: 100%; border-collapse: collapse;"> <tr> <td>TYPE <input style="width: 100%;" type="text"/></td> <td>FRAME <input style="width: 100%;" type="text"/></td> </tr> <tr> <td>CENT. FORCE lbs <input style="width: 100%;" type="text"/></td> <td>Hp <input style="width: 100%;" type="text"/></td> </tr> <tr> <td>FORCE CENT. kg <input style="width: 100%;" type="text"/></td> <td>Watts <input style="width: 100%;" type="text"/></td> </tr> <tr> <td>Volt <input style="width: 100%;" type="text"/></td> <td>ph <input type="text" value="3"/> Hz <input style="width: 100%;" type="text"/></td> </tr> <tr> <td>Amp. <input style="width: 100%;" type="text"/></td> <td>RPM <input style="width: 100%;" type="text"/></td> </tr> <tr> <td>RISE BY RES <input style="width: 100%;" type="text"/> °C</td> <td>MAX AMBIENT TEMP. <input style="width: 100%;" type="text"/> °C</td> </tr> <tr> <td>INS. CL. <input style="width: 100%;" type="text"/> LR CODE <input style="width: 100%;" type="text"/></td> <td>SF <input style="width: 100%;" type="text"/> DUTY <input type="text" value="CONT."/></td> </tr> <tr> <td>MECHANICAL PROT. <input style="width: 100%;" type="text"/></td> <td>DATE CODE <input style="width: 100%;" type="text"/></td> </tr> <tr> <td colspan="2" style="text-align: center;"> MAY BE USED WITH PWM INVERTER DRIVE - CONSTANT TORQUE PEUT ETRE UTILISE AVEC VARIATEUR DE FREQUENCES - COUPLE CONSTANT </td> </tr> <tr> <td colspan="2" style="text-align: center;"> 20 - <input style="width: 100%;" type="text"/> Hz </td> </tr> <tr> <td colspan="2" style="text-align: center;"> ATTENTION - UTILISER DES CABLES POUR 105°C MIN CAUTION - USE SUPPLY WIRE RATED 105°C MIN BEARING GREASE - GRAISSE DES ROULEMENTS KLUBER ISOFLEX TOPAS NB 52 </td> </tr> </table> <p style="text-align: center;">Stainless Nameplate P/N 820001</p> </div>	TYPE <input style="width: 100%;" type="text"/>	FRAME <input style="width: 100%;" type="text"/>	CENT. FORCE lbs <input style="width: 100%;" type="text"/>	Hp <input style="width: 100%;" type="text"/>	FORCE CENT. kg <input style="width: 100%;" type="text"/>	Watts <input style="width: 100%;" type="text"/>	Volt <input style="width: 100%;" type="text"/>	ph <input type="text" value="3"/> Hz <input style="width: 100%;" type="text"/>	Amp. <input style="width: 100%;" type="text"/>	RPM <input style="width: 100%;" type="text"/>	RISE BY RES <input style="width: 100%;" type="text"/> °C	MAX AMBIENT TEMP. <input style="width: 100%;" type="text"/> °C	INS. CL. <input style="width: 100%;" type="text"/> LR CODE <input style="width: 100%;" type="text"/>	SF <input style="width: 100%;" type="text"/> DUTY <input type="text" value="CONT."/>	MECHANICAL PROT. <input style="width: 100%;" type="text"/>	DATE CODE <input style="width: 100%;" type="text"/>	MAY BE USED WITH PWM INVERTER DRIVE - CONSTANT TORQUE PEUT ETRE UTILISE AVEC VARIATEUR DE FREQUENCES - COUPLE CONSTANT		20 - <input style="width: 100%;" type="text"/> Hz		ATTENTION - UTILISER DES CABLES POUR 105°C MIN CAUTION - USE SUPPLY WIRE RATED 105°C MIN BEARING GREASE - GRAISSE DES ROULEMENTS KLUBER ISOFLEX TOPAS NB 52	
TYPE <input style="width: 100%;" type="text"/>	FRAME <input style="width: 100%;" type="text"/>																						
CENT. FORCE lbs <input style="width: 100%;" type="text"/>	Hp <input style="width: 100%;" type="text"/>																						
FORCE CENT. kg <input style="width: 100%;" type="text"/>	Watts <input style="width: 100%;" type="text"/>																						
Volt <input style="width: 100%;" type="text"/>	ph <input type="text" value="3"/> Hz <input style="width: 100%;" type="text"/>																						
Amp. <input style="width: 100%;" type="text"/>	RPM <input style="width: 100%;" type="text"/>																						
RISE BY RES <input style="width: 100%;" type="text"/> °C	MAX AMBIENT TEMP. <input style="width: 100%;" type="text"/> °C																						
INS. CL. <input style="width: 100%;" type="text"/> LR CODE <input style="width: 100%;" type="text"/>	SF <input style="width: 100%;" type="text"/> DUTY <input type="text" value="CONT."/>																						
MECHANICAL PROT. <input style="width: 100%;" type="text"/>	DATE CODE <input style="width: 100%;" type="text"/>																						
MAY BE USED WITH PWM INVERTER DRIVE - CONSTANT TORQUE PEUT ETRE UTILISE AVEC VARIATEUR DE FREQUENCES - COUPLE CONSTANT																							
20 - <input style="width: 100%;" type="text"/> Hz																							
ATTENTION - UTILISER DES CABLES POUR 105°C MIN CAUTION - USE SUPPLY WIRE RATED 105°C MIN BEARING GREASE - GRAISSE DES ROULEMENTS KLUBER ISOFLEX TOPAS NB 52																							

Figure 2. Markings on MSVX Vibrators

Connecting power to vibrator

⚠ WARNING

Wire vibrator in accordance with National Electrical Code (Articles 430, 500, 501, and 502, as appropriate) and all applicable local codes. Have wiring installed by a qualified electrician only.

NOTE

An alternate conduit opening is provided at the bottom of the wiring box. To use alternate conduit opening, remove plug and tightly install it into top of wiring box. If using bottom conduit opening, wire power supply according to Diagram B, Figure 3.

Wire vibrators according to wiring Diagrams A or B in Figure 3.

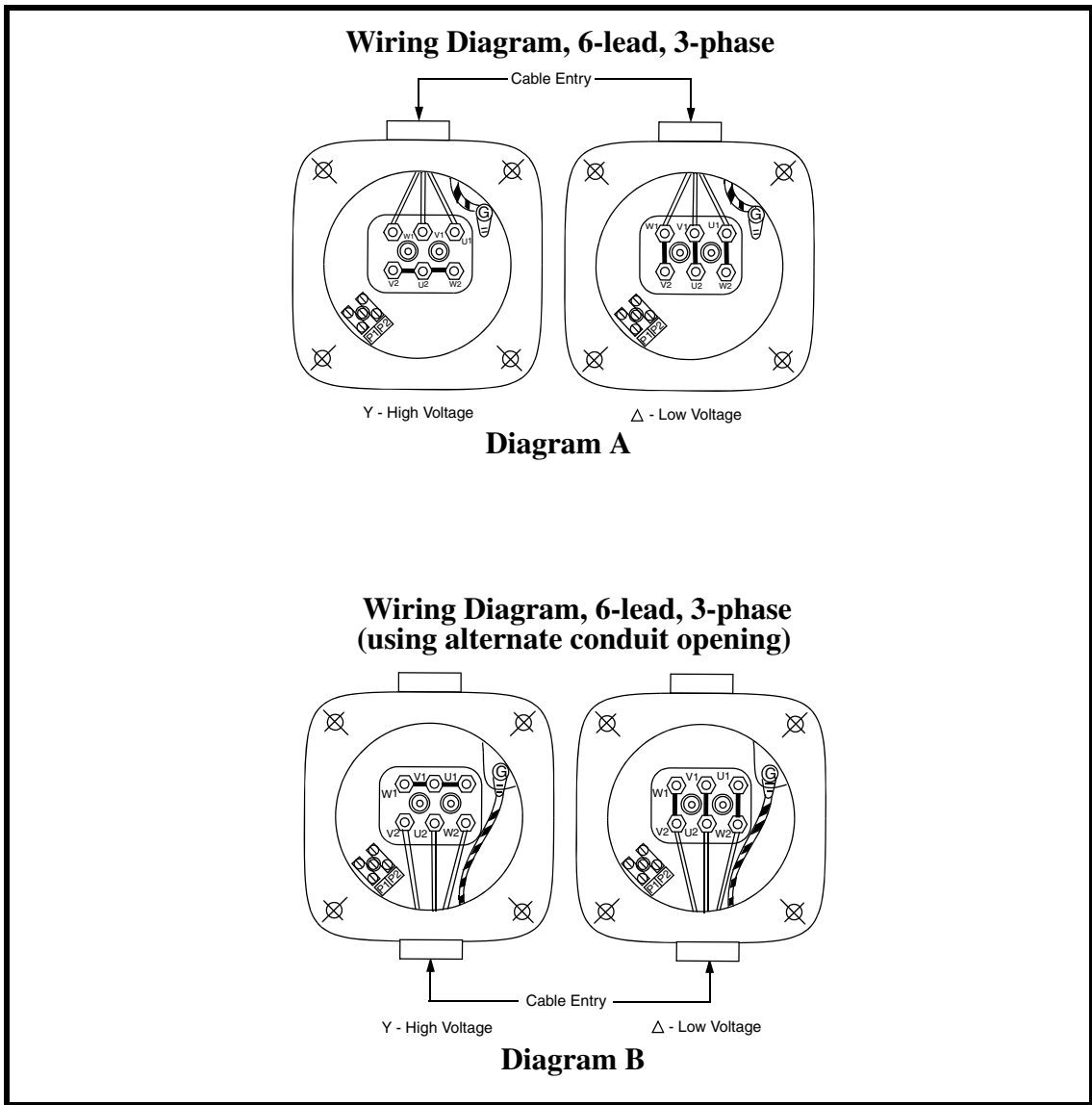

Figure 3. Wiring Diagrams

⚠ CAUTION

Before running cord to vibrator, make sure cord voltage rating equals or exceeds the voltage at which you will be operating the vibrator. It must have a minimum temperature rating of 222°F (105°C).

1. Remove wiring cover, o-ring, and rubber compression block. Install elbow. Install cord so that cord jacket extends into wiring compartment approximately 1 inch.

IMPORTANT

When wiring vibrator, leave slack in electrical cable so that cable does not become taut during vibration cycle and cause stress on wire connections. On applications where moisture is present, leave enough slack in power cable to prevent moisture from running down cable into vibrator.

2. Trim conductors and strip insulation approximately 1/4 inch. Wire vibrator according to wiring diagram inside terminal box or see Figure 3. Use closed-loop wire connectors only.

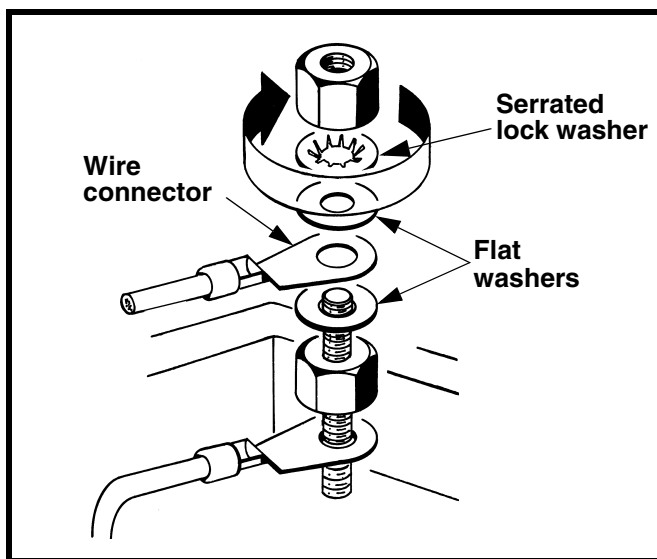

Figure 4. Installing Wire Connector

3. Install wire connector between the two flat washers. See Figure 4.

⚠ DANGER

Vibrator must be grounded using the power supply ground wire (or other if specified in the NEC). Failure to properly ground vibrator can cause severe injury or death.

4. Connect power supply ground wire (or other if specified in the NEC) to ground terminal. Ground terminal is a green zinc plated M6 bolt with serrated lock washer. Use closed loop wire connector only.

Installing overload, short-circuit and ground-fault protection

⚠ CAUTION

Install overload protection for vibrator. If vibrator is not protected from overload, vibrator can be damaged and warranty will be void. Determine size of overload protection according to NEC Article 430, and have it installed by a qualified electrician only.

1. Determine overload, short-circuit and ground-fault protection according to NEC Article 430.
2. Have qualified electrician install overload, short-circuit and ground-fault protection.
3. If overload trips during operation, fix problem before resetting.

⚠ CAUTION

For equipment using two vibrators, the two screen vibrators must be electrically interlocked. If using a single contactor, each screen vibrator must be provided with separate overload protection. The screen vibrator control circuit must be arranged so that if one screen vibrator becomes de-energized, the other screen vibrator will automatically and immediately become de-energized. Failure to properly interlock screen vibrators could result in damage to equipment if one vibrator fails.

4. If using two vibrators, interlock the two screen vibrators and install separate overload protection for each.

⚠ WARNING

Martin® Screen Vibrators have adjustable eccentric weights. Weight position must be the same on each end of vibrator.

Adjusting eccentric weights

IMPORTANT

For the most efficient operation, vibrator eccentric weights should be adjusted to the lowest force setting required to move the material. This will increase vibrator life and reduce energy costs.



⚠ WARNING

Before adjusting eccentric weights, turn off and lock out/tag out energy source to vibrator.

1. Before adjusting eccentric weights, turn off and lock out/tag out energy source to vibrator.
2. Remove weight cover and set aside along with screws, washers and o-rings.
3. Using a 1/2-in. ratchet, extension, and either a 10-mm or 14-mm socket, remove the socket-head screw as shown. See Figure 5.
4. Rotate adjustable weight to desired position number (see Figure 5) and secure in position with socket-head screw. Torque 14-mm socket-head screw to 137 ft-lb. Torque 10-mm socket-head screw to 28 ft-lb.

5. Replace weight cover, making sure o-ring is properly seated in weight cover.
6. Repeat steps 1 through 5 above on other side of vibrator. Adjust weight to same position number as in step 4 above.

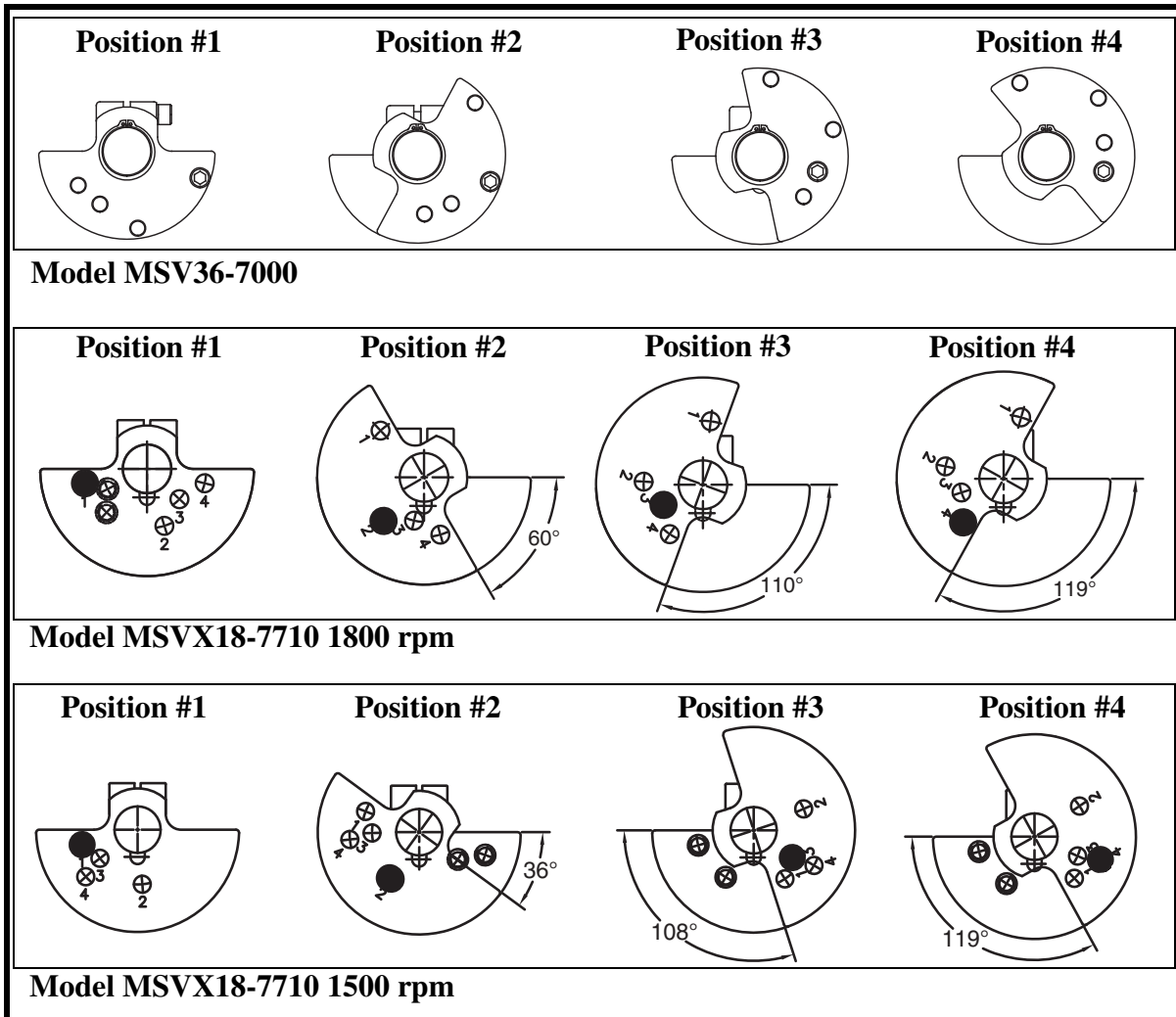

Figure 5. Vibrator Weight Settings

Table II. Vibrator Weight Settings

Model MSV36-7000, 3600 RPM	
Wt. Position #	Centrifugal Force, lb
2	7360
4	3680

Model MSV36-7000, 3000 RPM	
Wt. Position #	Centrifugal Force, lb
1	6140
3	3830

Model MSVX18-7710, 1800 RPM		
Wt. Position #	Unbalance (in-lb)	Centrifugal Force, lb
1	82.5	7710
2	71.9	6750
3	47.7	4400
4	41.8	3850

Model MSVX18-7710, 1500 RPM		
Wt. Position #	Unbalance (in-lb)	Centrifugal Force, lb
1	120.9	7710
2	106.4	6800
3	68.8	4400
4	60.2	3850

After Installing Vibrator

IMPORTANT

Read entire section before beginning work.

Checking shaft rotation

1. Remove one weight cover.

▲ WARNING

Before checking shaft rotation, make sure area is known to be non-hazardous.

▲ CAUTION

DO NOT run vibrator with eccentric weights removed. Running vibrator with eccentric weights removed will damage bearings.

▲ WARNING

When checking shaft rotation with weight cover removed, keep hands away from swinging weights. Weights can crush fingers.

2. Start vibrator(s) only for a few seconds, then stop.
3. Observe direction of screen vibrator rotation. If screen vibrator is not rotating in correct direction, **lock out/tag out energy source** and reverse rotation. To reverse rotation of three-phase vibrator, reverse any two of the three power supply wires. See Figure 6 or 7 for proper rotation.
4. Replace weight cover, taking care not to pinch o-ring.

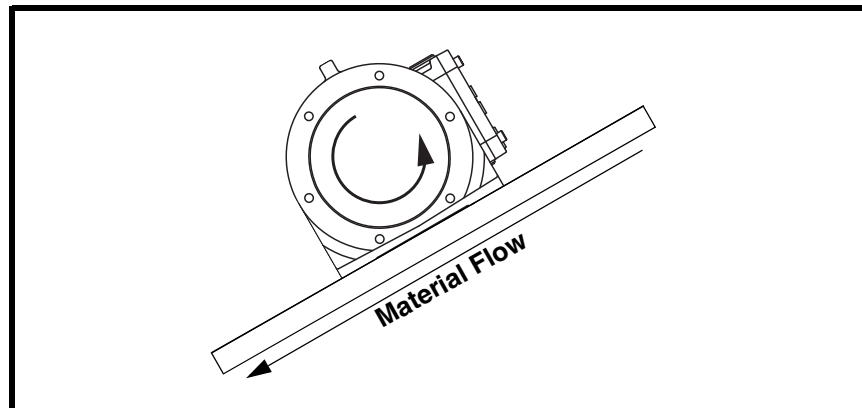

Figure 6. One-Vibrator Screen

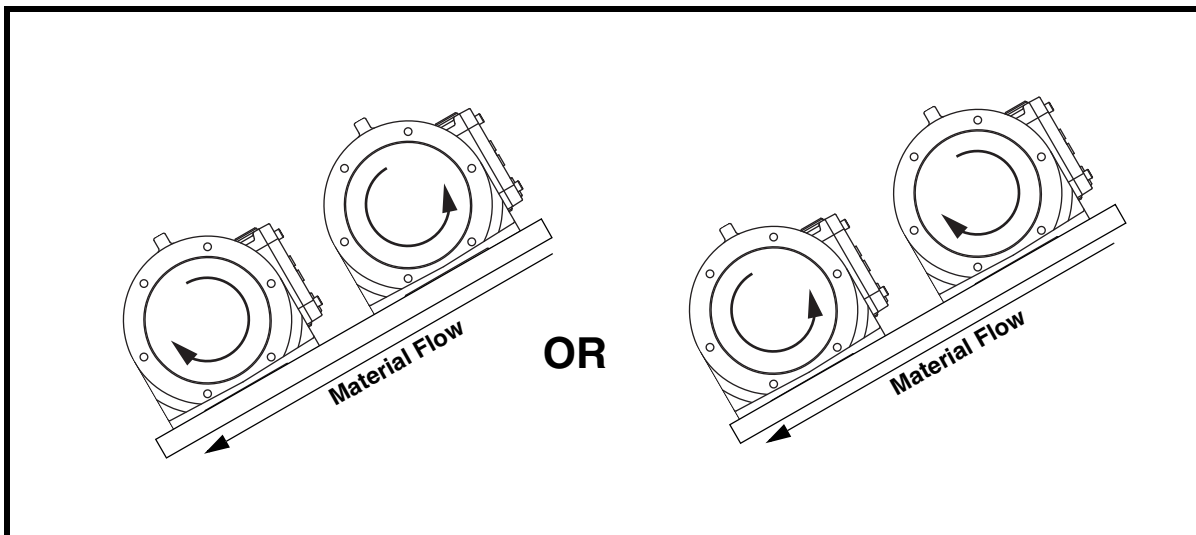

Figure 7. Two-Vibrator Screen

***Initial start-up/
checking line
current***

1. Close power supply disconnect switch and allow screen vibrator(s) to operate.
2. If vibrator makes unusual or excessive noise, make sure mounting bolts are tight.

▲ WARNING

Vibrator may produce loud noise during operation when mounted on structure. See OSHA 1910.95 for guidelines. If required, wear ear protection to avoid impairment or loss of hearing.

3. Check decibel level of vibrator noise during operation. See OSHA 1910.95 to determine whether noise exceeds safe limits. If required, wear ear protection to avoid impairment or loss of hearing.

▲ CAUTION

If vibrator is operated continuously with line current above nameplate rating, vibrator can be damaged.

4. After a few hours of operation, check each line current. If reading is higher than nameplate rating, check for correct phase voltage ensuring that it is correct and balanced. If phase voltages are correct ($\pm 10\%$ of nameplate rating) and balanced, recheck wiring, ensure that mounting bolts are correctly installed, or contact Martin Engineering for assistance. After making adjustments, check line current again to ensure line current does not exceed nameplate rating.
5. After first 8 hours of use and periodically thereafter, check mounting bolt torque and tighten if necessary.

*Variable
frequency inverter*

⚠ CAUTION

All screen vibrators can be supplied with a pulse-width modulated variable frequency inverter. NEVER operate the screen vibrator at a frequency higher than that specified on the nameplate. Damage to vibrator can result.

Do not operate screen vibrator at frequency higher than specified on nameplate. Throughout frequency range, verify that each line current does not exceed current rating on nameplate. If reading is higher than nameplate, consult inverter manual. If necessary, adjust inverter. After making adjustment, check line current again to ensure line current does not exceed nameplate rating.

Lubricating vibrator

IMPORTANT

Read entire section before beginning work. Allow vibrator to cool to ambient temperature before working on it.

NOTE

All vibrators are lubricated at the factory.

▲ CAUTION

Use only prescribed grease in vibrator. If a different grease is used, vibrator can be damaged and warranty will be void.

Use only prescribed amount of grease to lubricate vibrator. Too much grease will cause bearings to overheat and result in premature bearing failure.

1. Unless specified otherwise, lubricate the vibrator with 6.5 grams of Kluber Isoflex Topas NB 52 grease after the initial 500 hours of operation, and 13 grams every 1000 hours thereafter.
2. If screen vibrator housing temperatures exceed 194°F (90°C), cut lubrication time and amount in half for every 18°F (10°C) increment that meets or exceeds 194°F (90°C). For example, for operating temperature of 204°F (96°C), use 6.5 grams of grease per bearing every 500 hours. (Maximum bearing temperature allowed is 248°F [120°C].)

NOTE

Kluber grease may be purchased from Martin Engineering by calling 800-544-2947 or from Kluber Lubrication by calling 888-455-8237.

3. **For MSVX Model Vibrators**, lubricate with Kluber Isoflex Topas NB 52 grease only. Lubricate as follows:
 - a. Clean vibrator at each pipe plug in bearing flanges to remove dirt and debris. Remove pipe plug in each flange. Insert 1/8 in. NPT grease fitting. Add grease. Remove grease fittings; tightly replace pipe plugs.

Repairing screen vibrator and replacing bearings



Repairing vibrator or replacing bearings yourself during the warranty period may cause the warranty to be void. Contact Martin Engineering if motor needs repair or if bearings need to be replaced.

If screen vibrator needs repair or if bearings need to be replaced, call your local representative or Martin Engineering at **800-544-2947** for instructions.

Inspecting vibrator



At least quarterly, inspect cable and connections as follows:



Before inspecting vibrator, turn off and lock out/tag out energy source to vibrator.

1. Turn off and lock out/tag out energy source to vibrator according to ANSI standards (see “References”).
2. Inspect cable for damage including cuts and abrasions. Replace if damaged.
3. Inspect ground connection. Make sure resistance from ground connection to screen vibrator enclosure does not exceed 0.1 ohm. Ensure screw on ground terminal is tightened to proper torque (see Table I).
4. Make sure all nuts on connections on terminal block are tightened to proper torque. Do not overtighten (see Table I).
5. Check mounting bolt torque. See “Mounting Vibrator Onto Screen.”

Part Numbers

This section provides part numbers for the Martin® MSVX Series Screen Vibrators. Please reference part numbers when ordering parts.

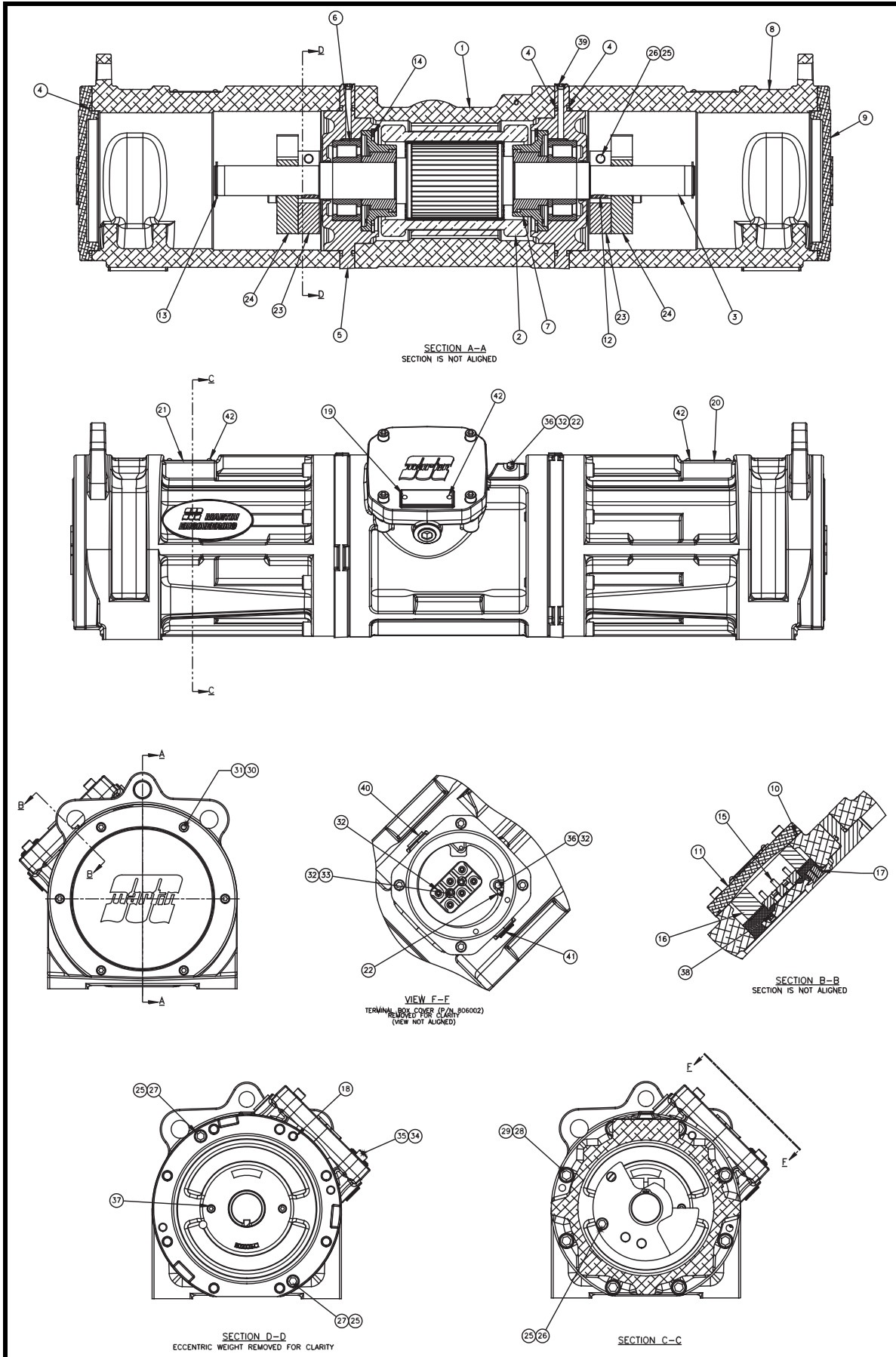

Figure 8. Martin[®] MSVX Screen Vibrator Part Numbers for MSV70X02-X

Item	Qty.	Description	Part Number
1	1	Inner Case	801003
2	1	Stator 4 Pole 70 FR	810004-02
3	1	Shaft Assembly	803002
4	6	O-ring #370 8.225 ID x .210 CS N 70A	508701
5	2	Bearing Flange	802002
6	2	Bearing Cylindrical Roller	506536
7	2	Bearing Cover	804002
8	2	Outer Case	801002
9	2	End Cover	805002
10	1	O-ring #259 6.234 ID x .139 CS N 70A	508560
11	1	Cover Terminal Box	806002
12	2	Key 14 x 9 x 25 MM	809001
13	2	Retaining Ring EXT A45 STD	500063
14	2	Retaining Ring Internal STD J150	500009
15	1	Terminal Block	812001
16	1	Rubber Block	813001
17	1	Cable Protection Sheath	814001
18	2	Dowel Pin D12 x 70 MM	506053
19	1	Nameplate Caution Disconnect	518147
20	1	Nameplate SST Warning Conduit Seal	518334
21	1	Nameplate Martin Stainless EP	820001
22	2	Sticker Ground Symbol	821001
23	2	Eccentric Weight Fixed	807044
24	2	Eccentric Weight Adjustable	807045
25	8	Washer Schnorr D12 VS Series ZPY	513006
26	4	Screw SHC M12 x 1.75 x 55 BO	515588
27	4	Screw SHC M12 x 1.75 x 45 BO	515612
28	16	Washer Schnorr D14 VS Series ZPY	513007
29	16	Screw SHC M14 x 2.0 x 90 BO	515665
30	12	Washer Schnorr D8 VS Series ZPY	513004
31	12	Screw SHC M8 x 1.25 x 25 DC	515508
32	10	Washer Schnorr D6 VS Series ZPY	513003
33	2	Screw SHC M6 x 1.0 x 20 BO	515504
34	4	Washer Schnorr D10 VS Series ZPY	513005
35	4	Screw SHC M10 x 1.5 x 40 BO	515539
36	2	Screw HHC M6 x 1.0 x 12 ZP Green	516555
37	4	Plug M12 x 12	509075
38	1	Plug M10 x 10 MM Socket Head	509008
39	2	Plug Pipe 1/8-NPT SS Dryseal	509078
40	1	Plug 3/4 NPT Pipe Plastic	11663
41	1	Plug Hex Socket 3/4-NPT SS Dryseal	514520
42	8	Screw Drive #7 x 1/4 Round Head	32873
43	1	Mounting Hardware Kit	36468

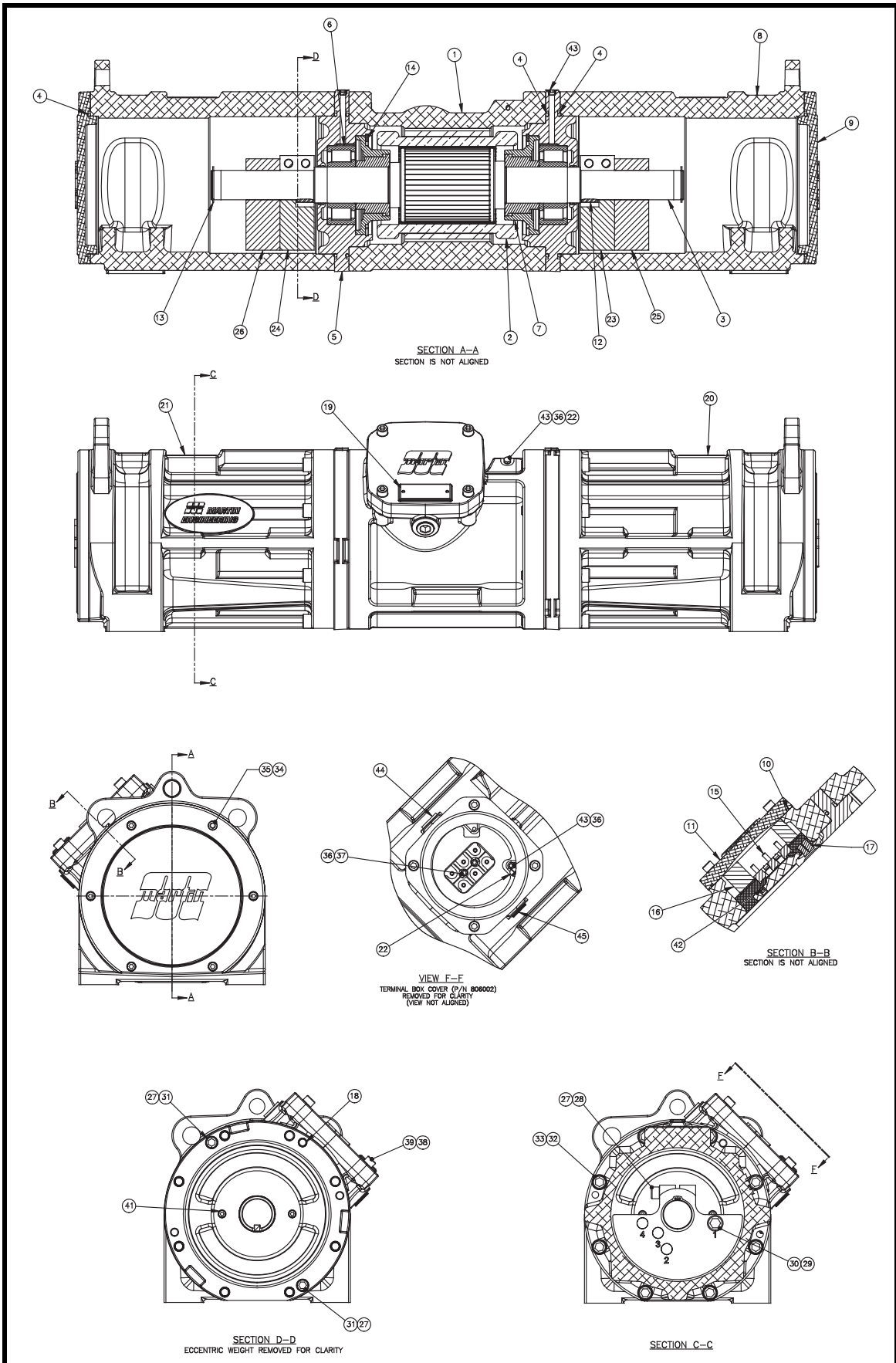

Figure 9. Martin® MSVX Screen Vibrator Part Numbers for MSVX170X04 and MSVX175X04

MSVX Vibrator			Part Number	
Item	Qty.	Description	MSVX170X04	MSVX175X04
1	1	Inner Case	801003	801003
2	1	Stator 4 Pole 70 FR	Table III	Table III
3	1	Shaft Assembly	803002	803008-1
4	6	O-ring #370 8.225 ID x .210 CS N 70A	508701	508701
5	2	Bearing Flange	802002	802007
6	2	Bearing Cylindrical Roller	506536	506551
7	2	Bearing Cover	804002	804004
8	2	Outer Case	801002	801002
9	2	End Cover	805002	805002
10	1	O-ring #259 6.234 ID x .139 CS N 70A	508560	508560
11	1	Cover Terminal Box	806002	806002
12	2	Key 14 x 9 x 25 MM	809001	809001
13	2	Retaining Ring EXT A45 STD	500063	500063
14	2	Retaining Ring Internal STD J150	500009	500009
15	1	Terminal Block	812001	812001
16	1	Rubber Block	813001	813001
17	1	Cable Protection Sheath	814001	814001
18	2	Dowel Pin D12 x 70 MM	506053	506053
19	1	Nameplate Caution Disconnect	518147	518147
20	1	Nameplate SST Warning Conduit Seal	518334	518334
21	1	Nameplate Martin Stainless EP	820001	820001
22	2	Sticker Ground Symbol	821001	821001
23	1	Eccentric Weight Fixed Right	Table III	Table III
24	1	Eccentric Weight Fixed Left	Table III	Table III
25	1	Eccentric Weight Adjustable Right	Table III	Table III
26	1	Eccentric Weight Adjustable Left	Table III	Table III
27	8	Washer Schnorr D12 VS Series ZPY	513006	513006
28	4	Screw SHC M12 x 1.75 x 55 BO	515588	515588
29	2	Washer Schnorr D16 VS Series ZPY	513008	513008
30	2	Screw SHC M16 x 2.0 x 80 BO	515619	515619
31	4	Screw SHC M12 x 1.75 x 45 BO	515612	515612
32	16	Washer Schnorr D14 VS Series ZPY	513007	513007
33	16	Screw SHC M14 x 2.0 x 90 BO	515665	515665
34	12	Washer Schnorr D8 VS Series ZPY	513004	513004
35	12	Screw SHC M8 x 1.25 x 25 DC	515508	515508
36	4	Washer Schnorr D6 VS Series ZPY	513003	513003
37	2	Screw SHC M6 x 1.0 x 20 BO	515504	515504
38	4	Washer Schnorr D10 VS Series ZPY	513005	513005
39	4	Screw SHC M10 x 1.5 x 40 BO	515539	515539
40	2	Screw HHC M6 x 1.0 x 12 ZP Green	516555	516555
41	4	Plug M12 x 12	509075	509075

MSVX Vibrator			Part Number	
Item	Qty.	Description	MSVX170X04	MSVX175X04
42	1	Plug M10 x 10 MM Socket Head	509008	509008
43	2	Plug Pipe 1/8-NPT SS Dryseal	509078	509078
44	1	Plug 3/4 NPT Pipe Plastic	11663	11663
45	1	Plug Hex Socket 3/4-NPT SS Dryseal	514520	514520

Table III. Martin® MSVX Screen Vibrator Part Numbers for MSVX170X04 and MSVX175X04

Part No.	P/N Item 2	P/N Item 23	P/N Item 24	P/N Item 25	P/N Item 26
MSVX170A04 MSVX175A04	810004	304460	304461	305499	305500
MSVX170C04 MSVX175C04	810004	304463	304463	305501	305502
MSVX170F04 MSVX175F04	810004-04F	304463	304463	305501	305502

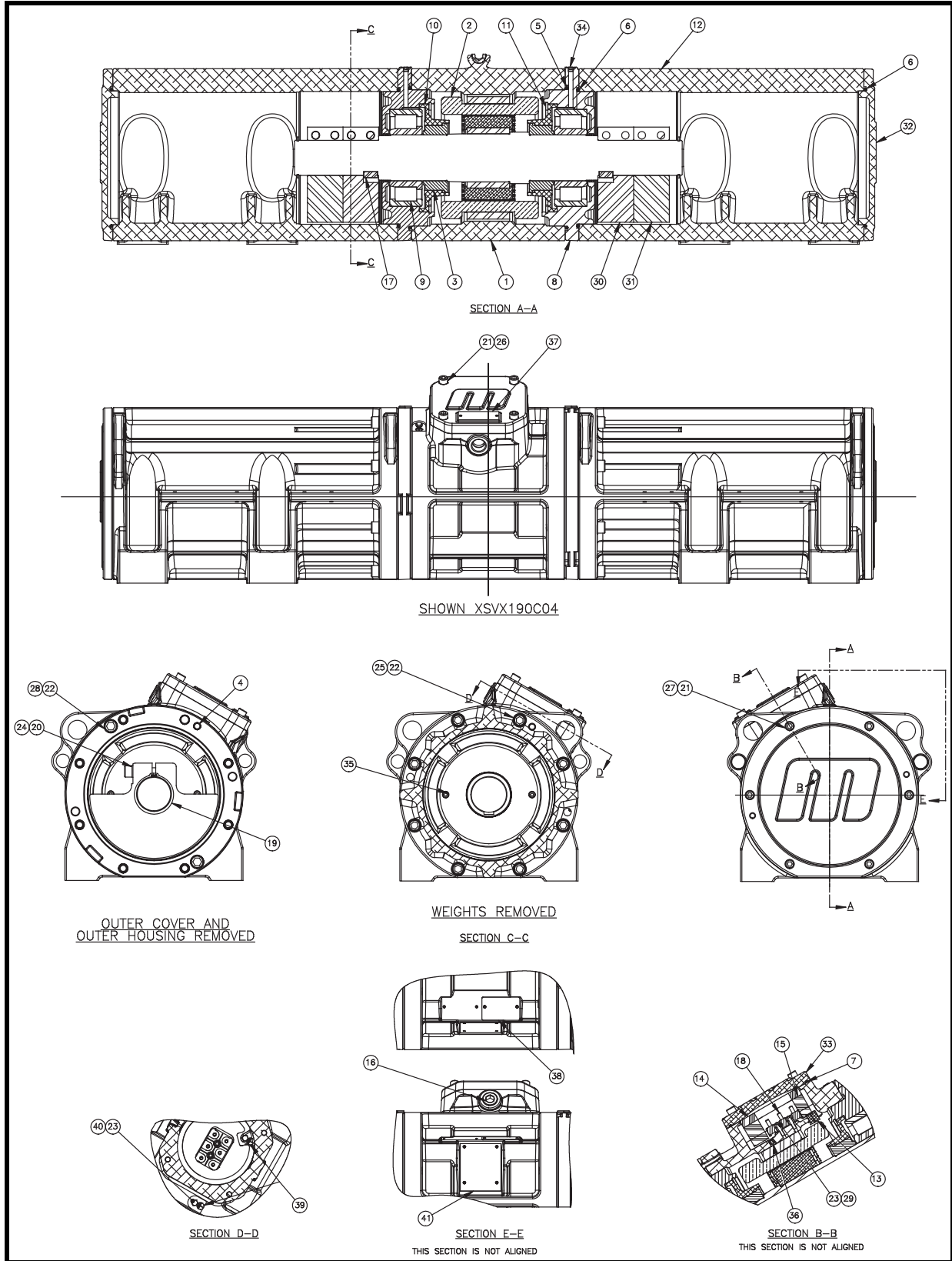

Figure 10. Martin® MSVX Screen Vibrator Part Numbers for MSVX190X04

Item	Qty.	Description	Part Number
1	1	Center Case	801016-01
2	1	Stator 4 Pole 95 FR	810012-4-5
3	1	Shaft Assembly	803016
4	2	Dowel Pin D12 x 70 MM	506053
5	2	O-ring #377 9.925 ID x .210 CS N 75A	818003
6	4	O-ring #376 9.725 ID x .139 CS N 70A	508656
7	1	O-ring #259 6.234 ID x .139 CS N 70A	508560
8	2	Bearing Flange	802016
9	2	Bearing Cylindrical Roller	506537
10	2	Bearing Cover	804016
11	2	Retaining Ring Internal STD J200	500068
12	2	Outer Housing Foot Mount	801016-02
13	1	Cable Protection Sheath	814001
14	1	Rubber Block Small	813002
15	1	Rubber Block	813001
16	1	Plug Hex Socket 3/4-NPT SS Dryseal	514520
17	2	Key	506032
18	1	Terminal Block	812001
19	2	Retaining Ring EXT A65 STD	500022
20	8	Washer Schnorr D14 VS Series ZPY	513007
21	16	Washer Schnorr D10 VS Series ZPY	513005
22	20	Washer Schnorr D16 VS Series ZPY	513008
23	4	Washer Schnorr D6 VS Series ZPY	513003
24	8	Screw SHC M14 x 2.0 x 70 BO	822006
25	16	Screw SHC M14 x 2.0 x 60 BO	515614
26	4	Screw SHC M10 x 1.5 x 40 BO	515539
27	12	Screw SHC M10 x 1.5 x 25 BO	515513
28	4	Screw SHC M16 x 2.0 x 45 BO	33945
29	2	Screw SHC M6 x 1.0 x 20 BO	515504
30	2	Weight Eccentric Fixed	Table IV
31	2	Weight Eccentric Adjustable	Table IV
32	2	Outer Cover	805016
33	1	Terminal Box Cover	806016
34	2	Plug 1/8-27NPTF Dryseal	509059
35	4	Plug M12 x 12	509075
36	1	Plug M10 x 10 MM Socket Head	509008
37	1	Nameplate Caution Disconnect	518147
38	1	Nameplate SST Warning Conduit Seal	518334
39	2	Sticker Ground Symbol	821001
40	2	Screw HHC M6 x 1.0 x 12 ZP Green	516555
41	1	Nameplate Martin Stainless EP	820001
42	8	Screw Drive #7 x 1/4 Round Head	32873

Table IV. Martin® MSVX Screen Vibrator Part Numbers for MSVX190X04

Part No.	P/N Item 30	P/N Item 31
MSVX190A04	807032-F	807032-A
MSVX190C04	807031-F	807031-A

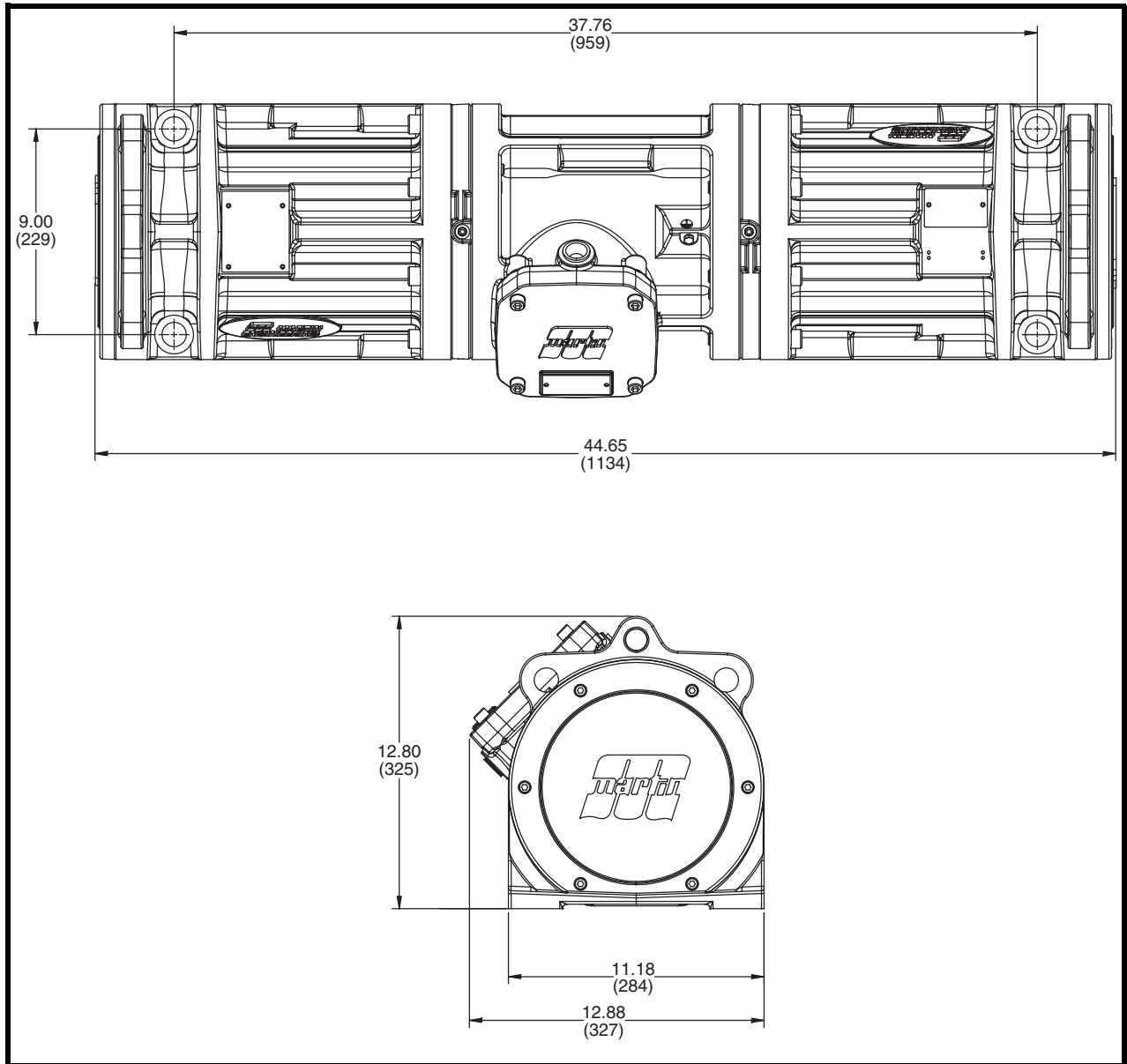

Figure 11. Martin® MSVX Screen Vibrator Dimensions, MSV70X02-X, MSVX170X04, and MSVX175X04

Dimensions

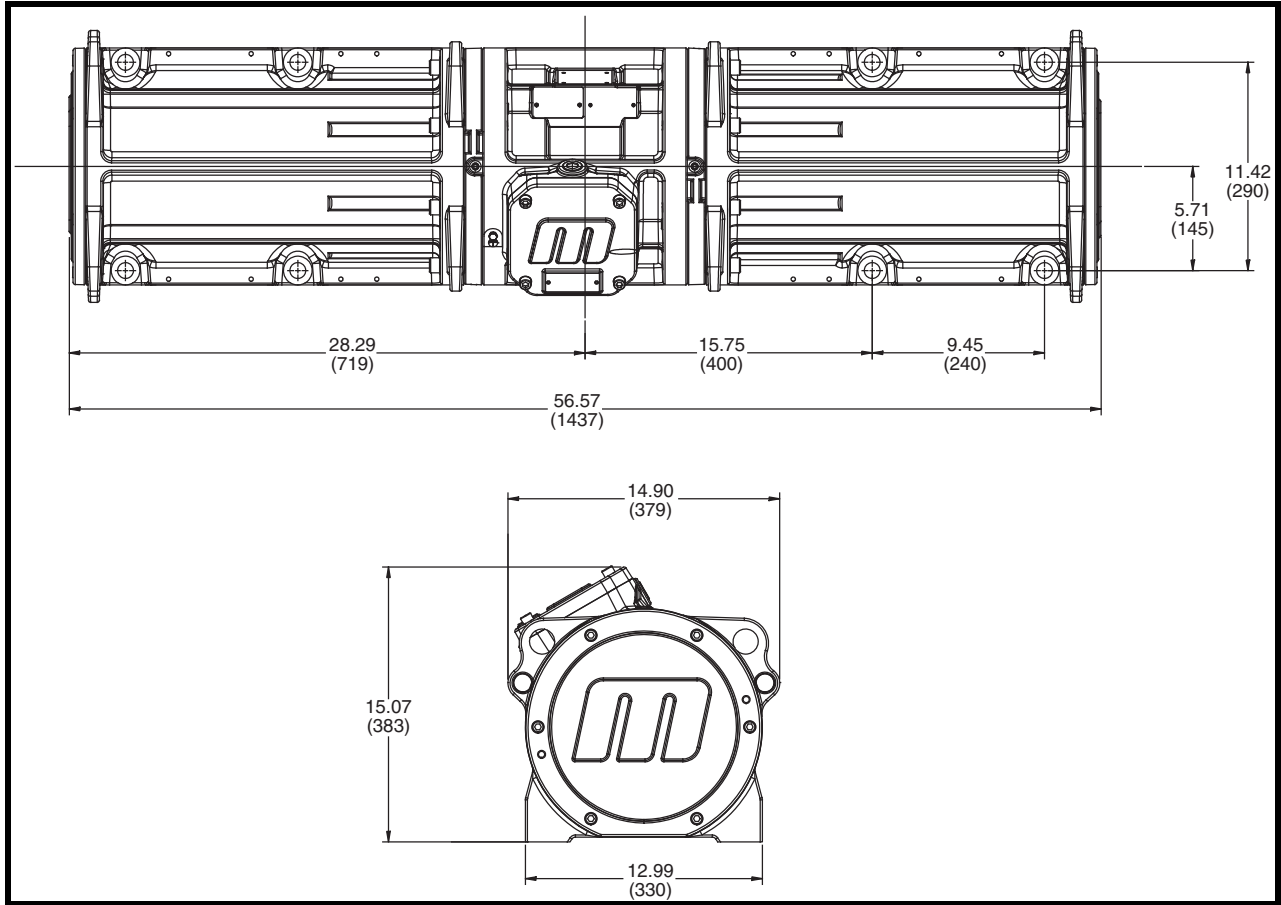
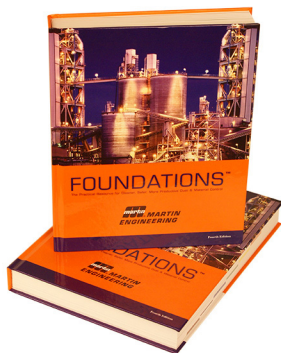

Figure 12. Martin® MSVX Screen Vibrator Dimensions, MSVX190X04

Any product, process, or technology described here may be the subject of intellectual property rights reserved by Martin Engineering Company. Trademarks or service marks designated with the ® symbol are registered with the U.S. Patent and Trademark Office and may be proprietary in one or more countries or regions. Other trademarks and service marks belonging to Martin Engineering Company in the United States and/or other countries or regions may be designated with the “TM” and “SM” symbols. Brands, trademarks, and names of other parties, who may or may not be affiliated with, connected to, or endorsed by Martin Engineering Company, are identified wherever possible. Additional information regarding Martin Engineering Company’s intellectual property can be obtained at www.martin-eng.com/trademarks.

Problem Solved™ GUARANTEED!



For nearly 20 years, Martin Engineering's Foundations™ Books have taught industry personnel to operate and maintain clean and safe belt conveyors. The Foundations™ Book, fourth edition, focuses on improving belt conveyors by controlling fugitive material. "The Practical Resource for Total Dust and Material Control," is a 576-page hard cover volume that provides information of value to industries where the efficient handling of bulk materials is a key to productivity and profitability.

Expanding upon the book, our Foundations™ Training Program addresses the design and development of more productive belt conveyors, and is offered in three customizable seminars. Attendees gain a better understanding of conveyor safety and performance, helping to justify upgrade investments and increase profitability.



Martin Engineering USA

One Martin Place
Neponset, IL 61345-9766 USA
800 544 2947 or 309 852 2384
Fax 800 814 1553
www.martin-eng.com

**COMPANY WITH
QUALITY SYSTEM
CERTIFIED BY DNV
= ISO 9001:2008 =**