

martin®

***Martin® Flanged
Electric Vibrator***



***Operator's Manual
M3900***

Important

MARTIN ENGINEERING HEREBY DISCLAIMS ANY LIABILITY FOR: DAMAGE DUE TO CONTAMINATION OF THE MATERIAL; USER'S FAILURE TO INSPECT, MAINTAIN AND TAKE REASONABLE CARE OF THE EQUIPMENT; INJURIES OR DAMAGE RESULTING FROM USE OR APPLICATION OF THIS PRODUCT CONTRARY TO INSTRUCTIONS AND SPECIFICATIONS CONTAINED HEREIN. MARTIN ENGINEERING'S LIABILITY SHALL BE LIMITED TO REPAIR OR REPLACEMENT OF EQUIPMENT SHOWN TO BE DEFECTIVE.

Observe all safety rules given herein along with owner and Government standards and regulations. Know and understand lockout/tagout procedures as defined by American National Standards Institute (ANSI) z244.1-1982, *American National Standard for Personnel Protection - Lockout/Tagout of Energy Sources - Minimum Safety Requirements* and Occupational Safety and Health Administration (OSHA) Federal Register, Part IV, 29 CFR Part 1910, *Control of Hazardous Energy Source (Lockout/Tagout); Final Rule*.

The following symbols may be used in this manual:



Danger: Immediate hazards that will result in severe personal injury or death.



Warning: Hazards or unsafe practices that could result in personal injury.



Caution: Hazards or unsafe practices that could result in product or property damages.



Important: Instructions that must be followed to ensure proper installation/operation of equipment.



Note: General statements to assist the reader.

Table of Contents

Section	Page
List of Figures	ii
List of Tables	ii
Introduction	1
General	1
References	1
Safety	1
Materials required	1
Storage	1
Before Installing Vibrator	2
Installing Vibrator	3
Nut and cap screw torque	3
Connecting power to vibrator	4
Installing overload, short-circuit, and ground-fault protection	6
After Installing Vibrator	7
Checking shaft rotation	7
Initial start up/checking line current	7
Variable frequency inverter	8
Maintenance	9
Lubricating vibrator	9
Repairing motor and replacing bearings	10
Inspecting vibrator	10
Part Numbers	11

List of Figures

Figure	Title	Page
1	Cord Grip Installation	5
2	Wiring Diagrams	5
3	Installing Wire Connector	6
4	Martin [®] Electric Vibrator, P/N's MFD70X04 and MFD70X06	12
5	Martin [®] Flanged Electric Vibrator Dimensions	15

List of Tables

Table	Title	Page
I	Vibrator Nut and Cap Screw Torque Requirements	3
II	Cord Grip Specifications	4
III	Lubrication Schedule For Each Bearing	9
IV	Martin [®] Flanged Electric Vibrator Model Numbers and Part Numbers	11
V	Martin [®] Flanged Electric Vibrator Part Numbers and Quantities.	14

Introduction

General

Martin® Flanged Electric Vibrators are designed and manufactured for use with vibrating machines such as circular screens or sifters. The vibrator motor has a recommended operational ambient temperature and mounting surface temperature range of -22 to 104°F (-30 to 40°C). If operating the motor in environments beyond these temperatures, call Martin Engineering, as the vibrator may require rating reduction, more frequent lubrication, or lubrication substitution.

References

The following documents are referenced in this manual:

- *The National Electrical Code (NEC)*, National Fire Protection Association, 1 Batterymarch Park, P.O. Box 9101, Quincy, MA 02269-9101.
- American National Standards Institute (ANSI) z244.1-1982, *American National Standard for Personnel Protection - Lockout/Tagout of Energy Sources - Minimum Safety Requirements*, American National Standards Institute, Inc., 1430 Broadway, New York, NY 10018.
- Code of Federal Regulation (CFR) 29, Part 1910, *Control of Hazardous Energy Source (Lockout/Tagout); Final Rule*, Department of Labor, Occupational Safety and Health Administration (OSHA), 32nd Floor, Room 3244, 230 South Dearborn Street, Chicago, IL 60604.
- CFR 29, Part 1910.15, *Occupational Noise Exposure*, Department of Labor, OSHA, 32nd Floor, Room 3244, 230 South Dearborn Street, Chicago, IL 60604.

Safety

All safety rules defined in the above documents and all owner/employer safety rules must be strictly followed when working on the vibrator.

Materials required

Only metric hand tools are required to install this equipment.

Storage

Store vibrator in an ambient temperature not less than 41°F (5°C) with a relative humidity not more than 60%. If the vibrator has been stored for 2 or more years, remove bearings, wash them, and repack them with new grease (see “Lubricating vibrator”).

Before Installing Vibrator

IMPORTANT

The delivery service is responsible for damage occurring in transit. Martin Engineering CANNOT enter claims for damages. Contact your transportation agent for more information.

1. Inspect shipping container for damage. Report damage to delivery service immediately and fill out delivery service's claim form. Keep any damaged goods subject to examination.
2. Remove Martin® Flanged Electric Vibrator from shipping container.
3. If anything is missing, contact Martin Engineering or a representative.



WARNING

Turn off and lock out/tag out all energy sources to equipment.

4. Before installing vibrator, turn off and lock out/tag out all energy sources to equipment according to ANSI standards (see "References").

WARNING

If equipment will be installed in an enclosed area, gas level or dust content must be tested before using a cutting torch or welding. Using a cutting torch or welding in an area with gas or dust may cause an explosion.

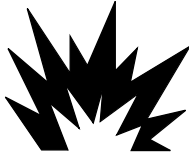

5. If using a cutting torch or welding, test atmosphere for gas level or dust content.
6. Make sure mounting surface is strong and flat, ± 0.01 in. (± 0.25 mm) across vibrator flange. (This will minimize internal stress to vibrator casting when tightening mount bolts. Welding in the area of the mounting surface could affect its flatness.)
7. Make sure mounting surface and vibrator are clean and free of debris.

IMPORTANT

Read entire section before beginning work. This manual provides instructions for installations onto steel equipment only. For other installations, call Martin Engineering or a representative.

▲ CAUTION

If installation instructions are not followed, equipment or vibrator can be damaged. Abusing or handling vibrator carelessly will accelerate wear and shorten bearing life.

Never weld equipment with vibrator mounted and wired. Welding may cause damage to motor windings and bearings.

Nut and cap screw torque

After removing any nuts or cap screws from vibrator assembly, re-install to the torque values specified in Table I.

Table I. Vibrator Nut and Cap Screw Torque Requirements

Cap Screws	ft/lb (kgm)	Shaft Nuts	ft/lb (kgm)	Terminal Block Nuts	ft/lb (kgm)
M6	7 (1)	M13x1	22 (3)	M4	0.87 (0.12)
M8	16.5 (2.3)	M15x1	36 (5)	M5	1.45 (0.20)
M10	35 (4.8)	M20x1	72 (10)	M6	2.17 (0.30)
M12	58 (8)	M25x1.5	123 (17)	M8	4.70 (0.65)
M14	94 (13)	M30x1.5	246 (34)	M10	9.80 (1.35)
M16	137 (19)	M45x1.5	360 (50)		
M18	195 (27)				
M20	275 (38)				

Connecting power to vibrator

⚠ WARNING

Wire vibrator in accordance with National Electrical Code Article 430. Have wiring installed by a qualified electrician only.

⚠ CAUTION

Before running cord to vibrator, make sure cord voltage rating equals or exceeds the voltage at which you will be operating the vibrator. It must have a minimum temperature rating of 221°F (105°C) and a diameter as shown in Table II. If wire is not proper diameter, cord grip will not tighten properly and vibrator could be damaged by moisture or material getting inside wiring compartment. If cord is damaged, it could short power supply or short to ground causing damage to vibrator.

1. Table II provides information on securing the electric vibrator cord grip when installing power supply and thermistor circuit cords. The frame size of the electric vibrator will define the size of the cord grip. Each cord grip is designed for a specific cord diameter range. When installed at the factory, the cord used is noted in Table II.

IMPORTANT

See Figure 1. The compression nut must be tightened to a position that will provide proper strain relief for the cord. If the compression nut is not tight enough, the electrical connections may be stressed. If the compression nut is too tight, the cord may be damaged. When using a factory cord, tighten the compression nut to a position that meets the specified “Distance Between Flats.”

Table II. Cord Grip Specifications

Frame Size	Metal Cord Grip					
	Size mm x 1.5	Part No.	Suitable Cord Diameter Range, mm	Cord Provided by Factory		
				Size	Nominal Diameter, in.	Distance Between Flats, in.
00, 01, 10	M20	511578	7–13	16/4	0.42	1/16 to 1/8
20–60	M25	511579	10–17	14/4	0.575	1/8 to 3/16
70	M25	511594	16–19	10/4	0.705	1/8 to 3/16
80–90	M32	511580	11–21	10/4	0.705	1/16 to 1/8
Thermistor Circuit Cord	M20	511578	7–13	16/3	0.39	1/16 to 1/8

Frame Size	Increased Safety Exe Plastic Cord Grip					
	Size mm x 1.5	Part No.	Suitable Cord Diameter Range, mm	Cord Provided by Factory		
				Size	Nominal Diameter, in.	Distance Between Flats, in.
00, 01, 10	M20	518396	6.5–12	16/4	0.42	1/16 to 1/8
20–70	M25	518397	9–16	14/4	0.575	1/16 to 1/8
80–90	M32	518398	13–21	10/4	0.705	1/16 to 1/8
Thermistor Circuit Cord	M20	518396	6.5–12	16/3	0.39	1/16 to 1/8

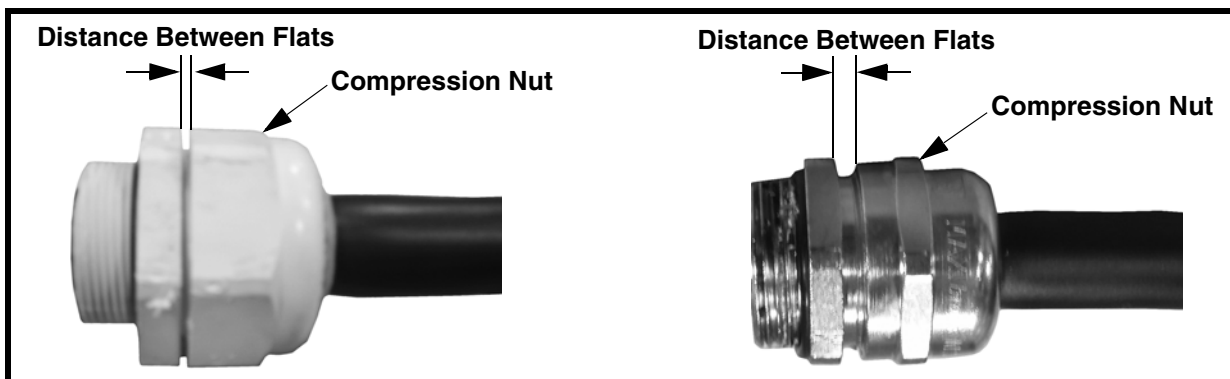

Figure 1. Cord Grip Installation

IMPORTANT

When wiring vibrator, leave slack in electrical cable so that cable does not become taut during vibration cycle and cause stress on wire connections. On applications where moisture is present, leave enough slack in power cable to prevent moisture from running down cable into vibrator.

2. Wire vibrator according to appropriate wiring diagram inside terminal box or see Figure 2. Use closed loop wire connectors only.

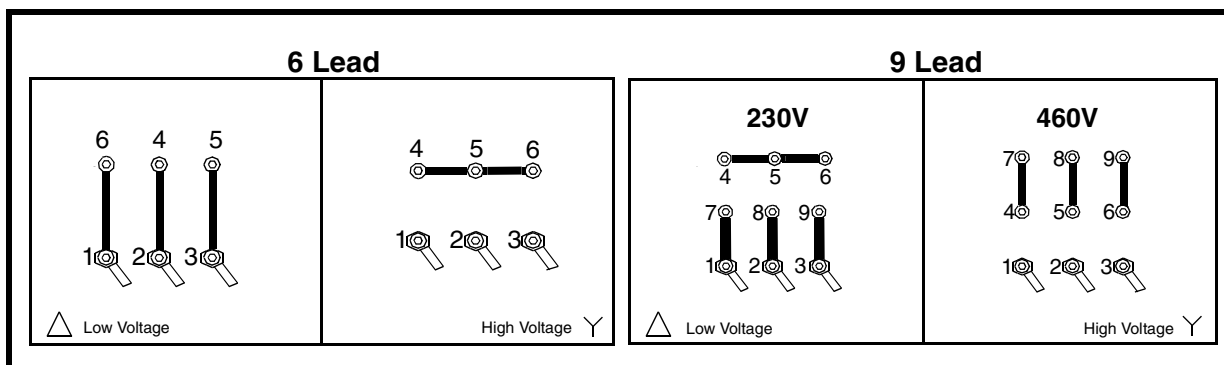

Figure 2. Wiring Diagrams

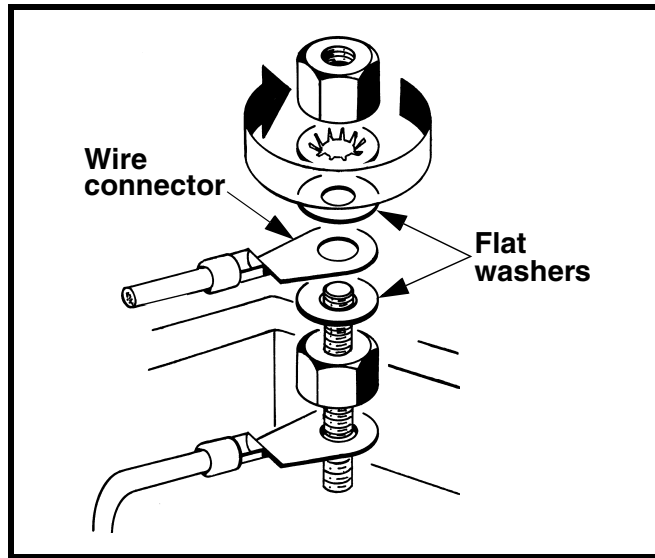

Figure 3. Installing Wire Connector

3. Install wire connector between the two flat washers. See Figure 3.

⚠ WARNING

Vibrator must be grounded using the power supply ground wire (or other if specified in the NEC). Failure to properly ground vibrator can cause severe injury or death.

4. Connect power supply ground wire (or other if specified in the NEC) to vibrator ground terminal. Use closed loop wire connectors only.
5. Reassemble wiring cover, o-ring, and rubber compression block(s), taking care not to pinch the o-ring. Tighten cord grip around supply line(s).

⚠ CAUTION

Install overload protection for vibrator. If vibrator is not protected from overload, vibrator can be destroyed and warranty will be void. Determine size of overload protection according to NEC Article 430, and have it installed by a qualified electrician only.

1. Determine overload, short-circuit, and ground-fault protection according to NEC Article 430.
2. Have qualified electrician install overload, short-circuit, and ground-fault protection.
3. If overload trips during operation, fix problem before resetting.

Installing overload, short-circuit, and ground-fault protection

After Installing Vibrator

IMPORTANT

Read entire section before beginning work.

⚠ WARNING

When checking shaft rotation, keep hands away from swinging weights. Weights can crush fingers.

Checking shaft rotation

1. Start vibrator for one second only, then stop.
2. Observe direction of motor rotation. If motor is not rotating in correct direction, lock out/tag out energy source and reverse rotation. To reverse rotation of three-phase vibrator, reverse any two of the three power supply wires.

Initial start-up/ checking line current

1. Close power supply disconnect switch and allow motor(s) to operate for 10 to 20 minutes.
2. If vibrator makes unusual or excessive noise, make sure mounting bolts are tight and mount welds are not damaged.

⚠ WARNING

Vibrator may produce loud noise during operation when mounted on structure. See OSHA 1910.95 for guidelines. If required, wear ear protection to avoid impairment or loss of hearing.

3. Check decibel level of vibrator noise during operation. See OSHA 1910.95 to determine whether noise exceeds safe limits. If required, wear ear protection to avoid impairment or loss of hearing.

⚠ CAUTION

Do not allow motor current to exceed nameplate rating. If vibrator is operated continuously with line current above nameplate rating, vibrator can be damaged.

4. After a few hours of operation, check each line current. If reading is higher than nameplate rating, reduce eccentric weight setting, stiffen vibrator mount, or move vibrator to more rigid location. After making adjustments, check line current again to ensure line current does not exceed nameplate rating.
5. After first 8 hours of use and periodically thereafter, check mounting bolts and tighten if necessary.

*Variable
frequency inverter*



All motors can be supplied with a pulse-width modulated variable frequency inverter. NEVER operate the motor at a frequency higher than that specified on the nameplate. Damage to vibrator can result.

Do not operate vibrator motor at frequency higher than specified on nameplate. Throughout frequency range, verify that each line current does not exceed current rating on nameplate. If reading is higher than nameplate, consult inverter manual. If necessary, adjust inverter, reduce eccentric weight setting, stiffen vibrator mount location, or move vibrator to more rigid location. After making adjustment, check line current again to ensure line current does not exceed nameplate rating.

IMPORTANT

Read entire section before beginning work. Allow vibrator to cool to ambient temperature before working on it.

NOTE

All vibrators are lubricated at the factory.

CAUTION

Use only prescribed grease in vibrator. If a different grease is used, vibrator can be damaged and warranty will be void.

Use only prescribed amount of grease to lubricate vibrator. Too much grease will cause bearings to overheat and result in premature bearing failure.

Lubricating vibrator

1. See Table III for lubrication schedule and amount of grease required for your vibrator.

NOTE

Kluber grease may be purchased from Martin Engineering by calling 800-544-2947 or from Kluber Lubrication by calling 603-434-7704.

2. Lubricate vibrator with Kluber Staburags NBU 8EP grease only. Lubricate as follows:
 - a. Clean vibrator case around grease fitting with clean shop towel.
 - b. Insert grease gun into grease fitting. Add grease.

Table III. Lubrication Schedule For Each Bearing

Model	Lube g	Lubrication Frequency hours
MFD12-2510, MFD18-2510	50 (top bearing) 25 (lower bearing)	1000

Repairing motor and replacing bearings



Do not attempt to repair vibrator motor or replace bearings yourself. If you attempt to do so during the warranty period, the warranty may be void.

If vibrator motor needs repair or if bearings need to be replaced, call Martin Engineering at **800-544-2947** for instructions.

Inspecting vibrator



At least quarterly, inspect cable and connections as follows:



Before inspecting vibrator, turn off and lock out/tag out energy source to vibrator.

1. Turn off and lock out/tag out energy source to vibrator according to ANSI standards (see “References”).
2. Inspect weight covers for cracks and check cap screws for tightness.
3. Inspect cable for damage including cuts and abrasions. Replace if damaged.
4. Inspect ground connection. Make sure ground connection to motor enclosure does not exceed 0.1 ohm. Ensure screw on ground terminal is tightened to proper torque (see Table I).
5. Make sure all nuts on connections on terminal block are tightened to proper torque. Do not overtighten (see Table I).

Part Numbers

This section provides part numbers for the Martin® Flanged Electric Vibrators and related equipment. Please reference part numbers when ordering parts.

**Table IV. Martin® Flanged Electric Vibrator
Model Numbers and Part Numbers**

Model No.	Part No.
MFD18-2510	MFD70X04
MFD12-2510	MFD70X06

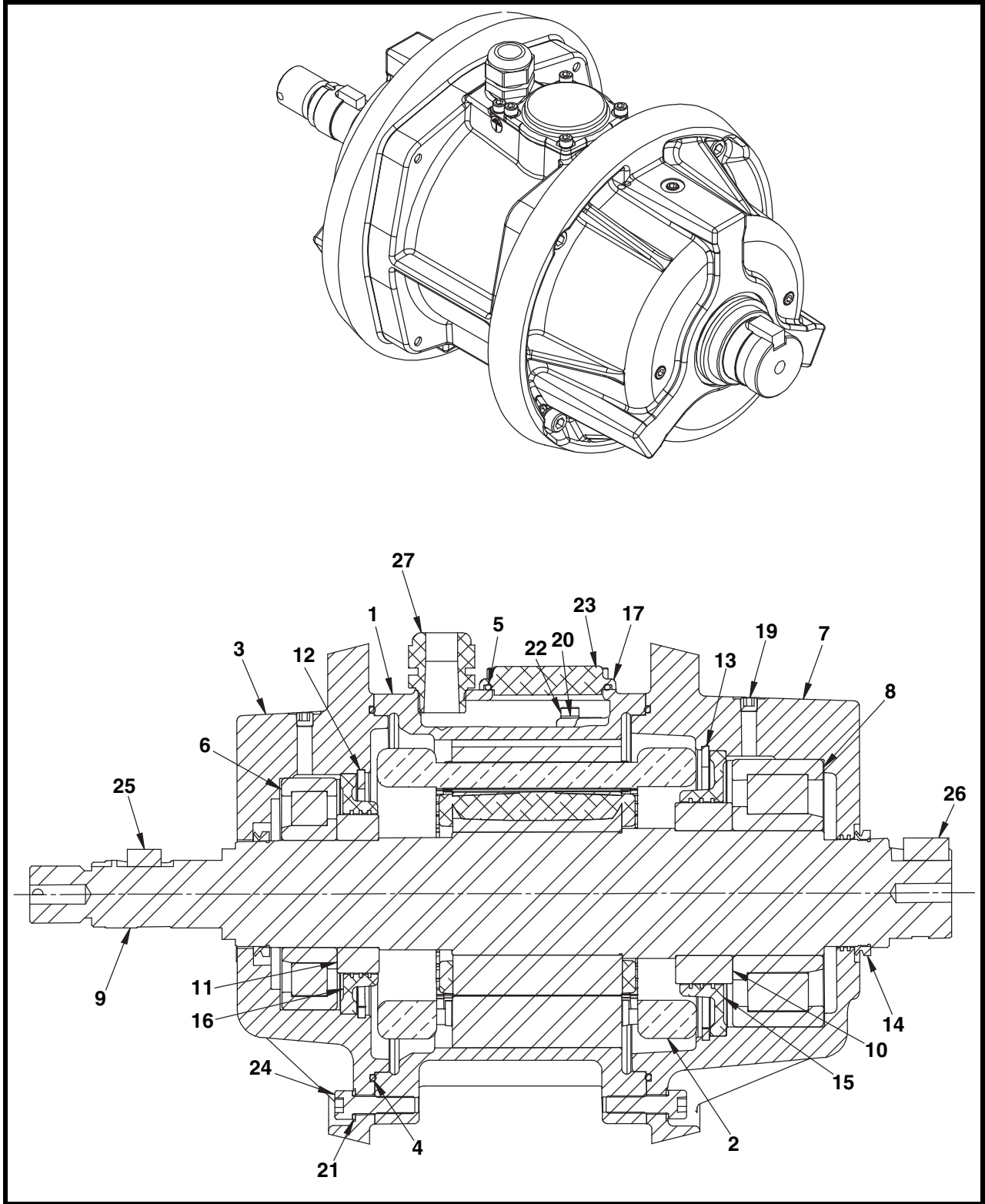

Figure 4. Martin® Electric Vibrator, P/N's MFD70X04 and MFD70X06

Item	Description	Part No.	Qty
1	Case	801013	1
2	Stator		1
3	Bottom Endcap	802013-B	1
4	O-ring #266 7.984 ID x .139 CS N70A	508601	2
5	O-ring #230 2.484 ID x .139 CS N70A	818005	1
6	Bearing Cylindrical Roller NJ312ECP	506562	1
7	Top Endcap	802013-T	1
8	Bearing Cylindrical Roller NJ2314ECP	506539	1
9	Shaft/Rotor Assembly	803013	1
10	Top Shaft Bushing	803013-BT	1
11	Bottom Shaft Bushing	803013-BB	1
12	Retaining Ring Internal STD J135	816009	1
13	Retaining Ring Internal STD J160	500064	1
14	V-ring Shaft Seal 60 mm	502069	2
15	Top Bearing Cover	804013-T	1
16	Bottom Bearing Cover	804013-B	1
17	Terminal Box Cover	806013	1
18 (NS)	Plug M10 x 10 mm Socket Head	509008	9
19	Plug 1/8-27NPTF Dryseal	509059	2
20	Washer Schnorr D6 VS Series ZPY	513003	6
21	Washer Schnorr D10 VS Series ZPY	513005	8
22	Screw SHC M6 x 1.0 x 12 BO	515601	2
23	Screw SHC M6 x 1.0 x 16 BO	515611	4
24	Screw SHC M10 x 1.5 x 35 BO	515514	8
25	Key 3/8 SQ x 3/4 LG	31389	1
26	Key 1/2 SQ x 1.00 LG	31390	1
27	Nylon Cord Grip 3/4-NPT Range .51/.71	823001	1
28 (NS)	Cord Electrical		6
29 (NS)	Connector Butt 16-14 AWG	31540	
30 (NS)	Ring Terminal 16-14 AWG F/1/4 Stud	35556-03	1
31 (NS)	Rubber Strip Foam Seal	813003	1
32 (NS)	Label Warning Exp Atmosphere	821002	1
33 (NS)	Sticker Ground Symbol	821001	2
34 (NS)	Nameplate	820003	1
35 (NS)	Screw Drive #7 x 1/4 Round Head	32873	4
36 (NS)	Operator's Manual	M3900	1
37 (NS)	Heat Shrinking Tube	39028	.25

Figure 4. Martin® Electric Vibrator, P/N's MFD70X04 and MFD70X06

Table V. Martin® Flanged Electric Vibrator Part Numbers and Quantities

Part Number	P/N Item 2	P/N Item 28	Qty Item 29
MFD70A04	810013-04	100503	9
MFD70C04	810013-04	100503	9
MFD70F04	810013-04F	100504	6

Part Number	P/N Item 2	P/N Item 28	Qty Item 29
MFD70A06	810013-06	100503	9
MFD70C06	810013-06	100503	9
MFD70F06	810013-06F	100504	6

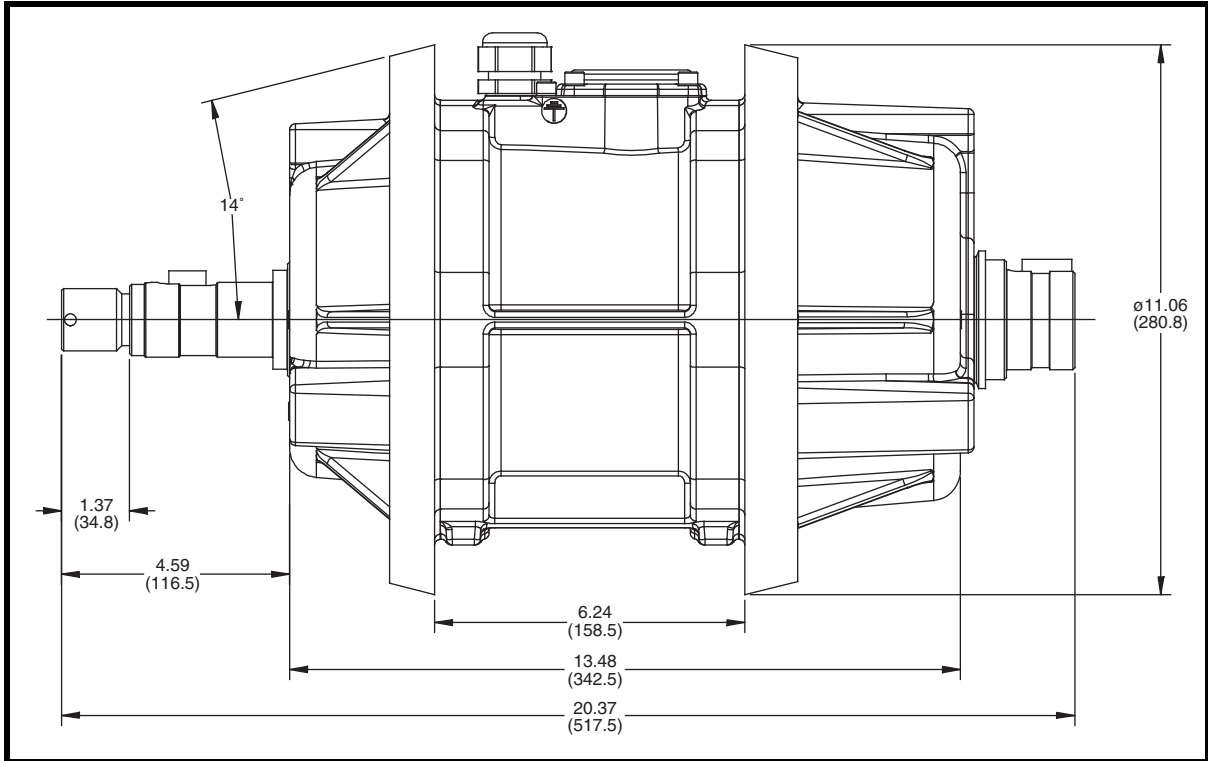

Figure 5. Martin® Flanged Electric Vibrator Dimensions

Notes

Any product, process, or technology described here may be the subject of intellectual property rights reserved by Martin Engineering Company. Trademarks or service marks designated with the ® symbol are registered with the U.S. Patent and Trademark Office and may be proprietary in one or more countries or regions. Other trademarks and service marks belonging to Martin Engineering Company in the United States and/or other countries or regions may be designated with the “TM” and “SM” symbols. Brands, trademarks, and names of other parties, who may or may not be affiliated with, connected to, or endorsed by Martin Engineering Company, are identified wherever possible. Additional information regarding Martin Engineering Company’s intellectual property can be obtained at www.martin-eng.com/trademarks.

Problem Solved™



Martin Engineering USA

One Martin Place
Neponset, IL 61345-9766 USA
800 544 2947 or 309 852 2384
Fax 800 814 1553
www.martin-eng.com

Subject to change without prior notice.

Quality Management System Certified by DNV - ISO 9001

**COMPANY WITH
QUALITY SYSTEM
CERTIFIED BY DNV
= ISO 9001:2008 =**