



# MARTIN® Hurricane Air Cannon



**Installation manual  
M3737UK**



<b>1</b>	<b>Contents</b> .....	<b>1</b>
<b>2</b>	<b>Introduction</b> .....	<b>3</b>
2.1	About this Installation Manual.....	3
2.1.1	Scope .....	3
2.1.2	Copyright .....	3
2.1.3	Disclaimer .....	3
2.1.4	Reference to additional documentation .....	5
2.1.5	Classification of hazards .....	6
2.2	Appropriate Use .....	7
2.2.1	Use in EX-protection areas .....	7
2.2.2	Operating limits of this product.....	8
2.3	Safety in the Workplace.....	8
2.3.1	Safety instructions, safety in the workplace.....	8
2.3.2	Obligations of the operator .....	9
2.3.3	Authorised personnel .....	9
<b>3</b>	<b>Product Description</b> .....	<b>10</b>
3.1	Explanation of the Function .....	10
3.2	Mode of Operation.....	11
3.3	Construction of the pressure tank.....	12
3.4	Serial number and Model number.....	13
3.5	Accessories required .....	13
3.6	Air Cannon service life.....	13
<b>4</b>	<b>Installation Preparation</b> .....	<b>14</b>
4.1	Prior to Installation.....	14
4.1.1	Materials and tools required .....	14
4.1.2	Preparatory measures .....	14
<b>5</b>	<b>Installation</b> .....	<b>16</b>
5.1	Safety Instructions.....	16
5.2	Installing the MARTIN® Hurricane Air Cannon .....	17
5.2.1	Installing the flange plate .....	17
5.2.2	Installing the nozzles.....	17
5.2.3	Joining the Air Cannon with the flange bracket .....	18
5.2.4	Installing the securing cable.....	18
5.2.5	Connecting the Air Cannon to the air supply .....	20
5.2.6	Pneumatic installation of the 5/2-way solenoid.....	22
5.2.7	Solenoid valve cabinet.....	25
5.2.8	Electrical Installation of the solenoid valve cabinet.....	29
5.3	Attaching the warning label or the warning tag .....	30
5.4	Test run.....	31
5.4.1	Check the installation of the MARTIN® Hurricane air cannon .....	31
<b>6</b>	<b>Maintenance</b> .....	<b>34</b>
6.1	Safety Instructions.....	34
6.2	Regular Maintenance inspections.....	35
6.3	Annual Maintenance or after 50,000 shots .....	35
6.4	Replacement of the MARTIN® Hurricane Venting Valve ...	37
6.4.1	Dismantling the venting valve.....	37

6.4.2	Installing the venting valve.....	40
<b>7</b>	<b>Troubleshooting.....</b>	<b>44</b>
7.1	Safety Instructions .....	44
7.2	Troubleshooting .....	44
<b>8</b>	<b>Storage, deinstallation, disposal .....</b>	<b>47</b>
8.1	Packing and transportation .....	47
8.2	Storage .....	47
8.3	Deinstallation .....	47
8.4	Disposal .....	47
<b>9</b>	<b>Part numbers.....</b>	<b>48</b>
9.1	Explanation of part numbers .....	48
9.2	Accessories. ....	49
9.3	Components and retrofit sets for the control system of the compressed air supply .....	49
9.4	Spare parts .....	49
9.5	MARTIN® Hurricane Air Cannon .....	50
9.6	Part numbers of the MARTIN® Hurricane exhaust valve cover.....	52
<b>10</b>	<b>Specifications .....</b>	<b>55</b>
10.1	Compressed air specifications .....	55
10.2	Values of tightening torque during installation .....	55
<b>11</b>	<b>Declaration of Incorporation .....</b>	<b>57</b>

## 2 Introduction

---

### 2.1 About this Installation Manual

Non-compliance with this installation manual can lead to the loss of any liability claim and/or guarantee.

#### 2.1.1 Scope

This installation manual applies exclusively to the product described herein and is aimed at those individuals who install this product, put it into operation and monitor its use.

#### 2.1.2 Copyright

The product described and this installation manual are protected by copyright. Copying without a license will be legally prosecuted. All rights to this document are reserved, including the reproduction and/or distribution in any thinkable way or form. The reprinting of this document is only allowed with written permission from Martin Engineering.

The technical standard at the time of delivery of the product and technical documentation is decisive, as long as no other information is given. We reserve the right to make technical changes without any announcement. Earlier documents will no longer be valid. Martin Engineering General Conditions of Sale and Delivery apply.

#### 2.1.3 Disclaimer

Martin Engineering guarantees the faultless operation of the product according to the advertising, edited product information, and technical documentation. Martin Engineering does not accept any liability for the efficiency and proper operation, if this product is used for any other purpose, other than as described in the chapter "Appropriate Use"; or for any damage caused by the use of accessories and/or spare parts, that were not delivered and/or certified by Martin Engineering.

The products from Martin Engineering are designed for a long service life. They conform to the respective current state-of-the-art science and technology and they have been thoroughly tested prior to delivery. In addition to continuous advanced development of products, Martin Engineering also conducts constant product and market analyses.

In the event of faults and/or technical problems Martin Engineering offers professional support. Appropriate steps will be taken immediately. Martin Engineering's warranty conditions apply, which can be sent if required.

## 2.1.4

### Reference to additional documentation

The following documents are referred to in this installation manual:

- MARTIN® Hurricane installation instructions for air cannon nozzles and flange brackets - M3773
- MARTIN® Hurricane air cannon maintenance instructions - M3747
- MARTIN® air cannon control system - M3592

The following standards and directives were applied when composing this installation manual:

- EU Machinery Directive (2006 / 42 / EC)
- EU - Directive, Simple Pressure Tanks 2009/105/EC
- EU Pressure Equipment Directive (97/23/EC)
- ISO/IEC Guide 37 "Installation instructions for end-consumer used products", edition 1995
- DIN 1421 "Structure and numbering in texts", edition 1983-01
- DIN/EN 12100 "Safety of machinery - Basic concepts, general principles of design", edition 2013-08
- DIN / ISO 16016 "Technical product documentation - Protection notices for restricting the use of documents and products", edition 2007-12
- DIN EN 953 Safety of machinery - Guards - General requirements for the design and construction of fixed and movable guards.
- DIN EN 4414:2011-04 "Pneumatic fluid power - General rules and safety requirements for systems and their components".
- DIN/EN 60204-1 "Safety of machinery - Electrical equipment of machines, Part 1, General requirements", edition 1998-11
- DIN EN 82079-1 Preparation of instructions for use - Structuring, content and presentation - Part 1: General principles and detailed requirements.

2.1.5

Classification of hazards



**DANGER!**

This indicates an imminent danger that leads to serious physical injuries or death, if not avoided.



**WARNING!**

This indicates a potentially dangerous situation that could lead to serious physical injuries or death, if not avoided.



**CAUTION!**

Indicates a potentially dangerous situation that could lead to minor bodily injury and/or damage to property if not avoided.



**NOTE**

Contains information to the installation or use of the product and points to situations, that cause neither injuries nor property damage, but is nevertheless important information.



## 2.2

### Appropriate Use

MARTIN® Hurricane air cannons, referred to as air cannons in the following, are used to clean bulk materials storage and transport containers of adhesive material. Depending on the model variant, they can be used on bulk goods containers or flue gas ducts with an internal temperature of up to 1,370°.

Air Cannons should be used only in zones having certain ambient temperatures as specified on the respective nameplate. Please see also Fig. 2 on page 13 for this purpose.

Any other use of this product is deemed to be inappropriate. If you wish to use the product for any other purpose, please contact Martin Engineering Customer Service. We will be happy to assist you with product configuration.

### 2.2.1

#### Use in EX-protection areas

Under certain circumstances, this product can also be used in potentially explosive areas. Contact Martin Engineering for more information on use in potentially explosive areas.

**2.2.2 Operating limits of this product**

The use of the product mentioned here is allowed only within the specified specifications. Using it in a higher than specified equipment category or under operating conditions other than those named and previously specified by Martin Engineering is considered to be inappropriate use and can only be carried out if approved by Martin Engineering.

If this product is meant to be used for a different purpose, then Martin Engineering or a representative can help with the product configuration.

**2.3 Safety in the Workplace****2.3.1 Safety instructions, safety in the workplace**

This installation manual must be read through in full prior to commencing work on the product or the customer's conveyor belt.

The operator must ensure that all installation, inspections, and maintenance tasks are carried out exclusively by authorised experts.

All work on conveyor belts and their accessories must always be carried out only when the system is at a standstill. It is essential that the procedures described in the relevant installation manual which explain how to shut down the conveyor system are followed.

Upon completion of work, all safety equipment and protective guards must be reinstalled and put back into operation.

Prior to commissioning, installation must be completed. Before the conveyor belt can be put back into operation, the flawless execution of all steps should be checked and verified. All notes on installation and commissioning of the product should be observed.

### 2.3.2 Obligations of the operator

The operator of this product must ensure that the personnel entrusted with the installation, maintenance and use of this product are only those personnel who

- are fully aware of regulations governing safety at work and accident prevention,
- are instructed in the use of the product and have read and understood this installation manual in full.

### 2.3.3 Authorised personnel

Personnel are considered to be authorised when they have completed the necessary training, hold the technical experience, knowledge of the relevant standards and directives and are also in a position to assess any task in order to recognise a critical situation in a timely fashion and at an early stage.

#### **Operational, Maintenance and Installation Personnel**

Personnel are considered to be authorised if they have been instructed in the use of the product and have read and understood this installation manual in full.

## 3

# Product Description

---

### 3.1

## Explanation of the Function

The air cannon is used to eliminate deposits, bridging, rat holes or other forms of adhesive material. To do this, the air cannon "shoots" compressed air via pipes or special nozzles in the bulk goods tank or, for example, in flue gas ducts. As a result, the adhesive deposits formed are removed and material can flow uninterruptedly.



### NOTE

Martin Engineering is not liable for damage to the operator's system that is caused by incorrect installation of the air cannon. Only used trained personnel for the installation and maintenance. If there are any problems contact Martin Engineering or an authorized dealer.



### DANGER!

When deploying other cleaning techniques such as, for example, use of compressed CO<sup>2</sup>, water lances or other cleaning techniques in conjunction with the use of air cannons, these must be protected with additional safety devices such as, for example, butterfly valves against pressure waves caused by air or high water pressure.

### 3.2

### Mode of Operation

The pressure tank (1) of the air cannon is loaded by filling it with air (2) up to a maximum pressure of 10 bar. The filling operation is complete when the pressure in the pressure tank has reached the pressure level in the supply line (3) and the air cannon is ready for use. By activating a solenoid, a positive (pressure-applied) signal is sent to the venting valve, as a result of which the latter gets triggered and the pressure in the valve chamber gets released. This piston is reset immediately by the pressure in the pressure tank and the compressed air is discharged from the pressure tank in the form of an air blast through an outlet pipe or a blow nozzle in the region to be cleaned (4).

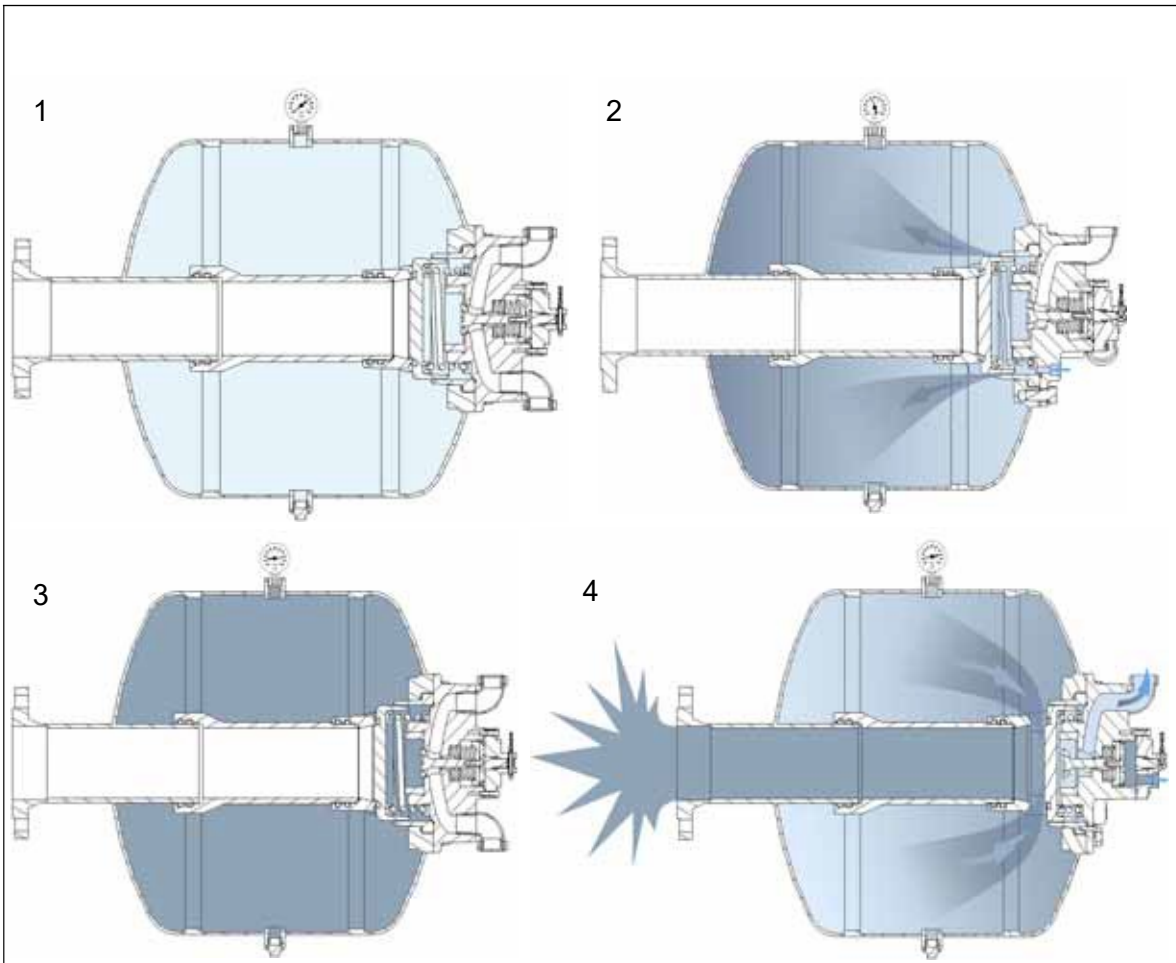

Fig. 1: Filling and discharging the air cannon

3.3

Construction of the pressure tank



**WARNING! EXPLOSION HAZARD**

The pressure tank may explode as a result of flying sparks or mechanical strains.

*Never weld the pressure tank and never expose the pressure tank to mechanical stresses (by fluctuations) such as, for example, jamming or mechanical strains.*

*Vent the air cannon before any installation or maintenance work.*

In case of any technical modification of the pressure tank or any pressure-related parts, the CE mark becomes null and void, and deployment in the context of the EU Machinery Directive (2006/42/EC) is no longer permissible.

The pressure tank of the air cannon is manufactured in accordance with the EU Directive 2009/105/EC. To protect it against corrosion, the pressure tank is coated inside at the factory.

### 3.4

#### Serial number and Model number

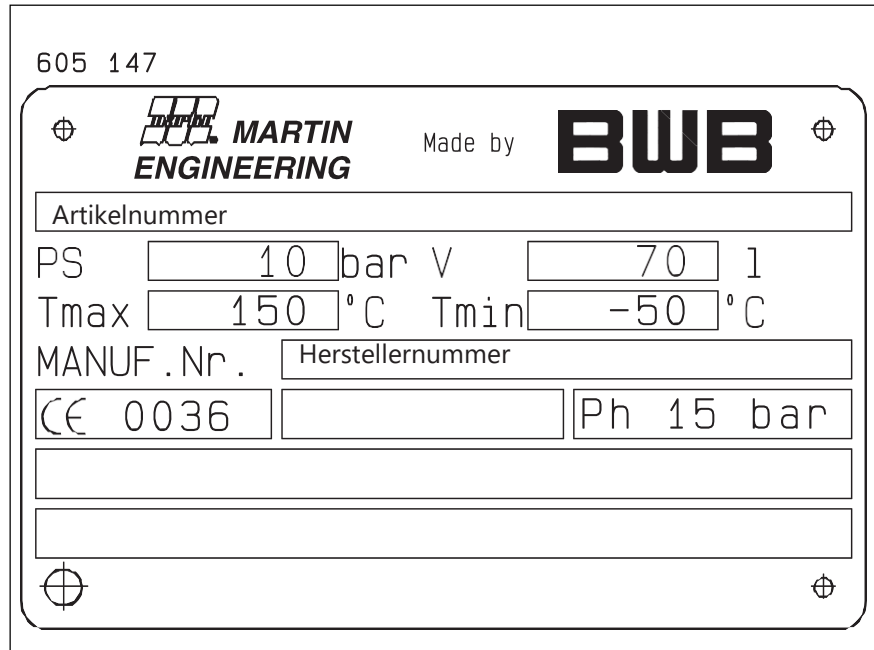

Fig. 2: Nameplate of the pressure tank

The serial number and model number are specified on the nameplate that is affixed on the air cannon. Please mention these numbers every time that you place an order for spare parts on Martin Engineering or an authorised dealer and in any correspondence.

### 3.5

#### Accessories required

Various accessories are necessary for the complete operational capability of the air cannon. These comprise, for example, solenoids, filters, controllers, pressure gauges, ball cocks, hoses, flange brackets and nozzles and they can be purchased from Martin Engineering. Please also refer to chapter 9, "Part numbers" in this installation manual for this purpose.

It may be necessary to use different accessories depending on the conditions of use. Please contact Martin Engineering or their authorised dealers for this purpose.

### 3.6

#### Air Cannon service life

Depending on the external conditions and the process parameters, a service life of up to 10 years is possible for the complete air cannon if all local and/or international pressure vessel regulations and the required maintenance and inspection intervals for the air cannon pressure vessel, the valves and all accessories are complied with.

## 4 Installation Preparation

---

### 4.1 Prior to Installation

#### 4.1.1 Materials and tools required

If any special tools are required in addition to standard tools for the installation and maintenance of the air cannon, this shall be indicated at the appropriate locations.

#### 4.1.2 Preparatory measures



##### NOTE

Pay attention to the following checks and carry them out carefully and completely.

The freight forwarder is responsible for any transport damage! For any damage claims, please contact the freight forwarder.



##### NOTE

A product that has not been installed properly or correctly may disrupt the conveyance process and contaminate the bulk material to be transported.

The operator is therefore responsible for implementing the necessary counter measures.

For applications involving dirt or impurities, please contact Martin Engineering or one of its representatives for advice.

1. Check the delivery with respect to the following:
  - Is the delivery complete? Is the number of pallets/cases/containers the same as the number on the delivery note?
  - Does all the transport packaging appear to be undamaged? Is there damage which may indicate that the contained products may be damaged?
2. If the delivery is incomplete or there is any transit damage, make sure that this is documented and have the freight forwarder confirm the same. All damaged products should be saved for inspection.



3. Depending on the scope of the order, the delivery should contain the following parts:
  - MARTIN® Hurricane Air Cannon
  - Installation and operating material depending on delivery.
  - Installation manual, plus warning and safety labels.
4. Missing or damaged parts must be reported to Martin Engineering or the authorised dealer.
5. Make sure that there is sufficient pressure relief if compressed air is being discharged in closed systems. In this way, it can be prevented that the internal pressure reaches values that may lead to the system getting damaged. Moreover, attention needs to be paid to the specific design parameters of the system. The temporary rise of air pressure in the system after discharging the MARTIN® air cannon can be calculated with the help of the following equation:

$$p = \frac{\text{Air cannon pressure} \times \text{Air cannon volume}}{\text{Aircannonvolume} + \text{free volume in vessel}}$$

6. If the air pressure calculated exceeds the system-specific overpressure, one or more pressure relief system(s) must be installed to protect the system. Observe and follow all legislation and standards in the process.

## 5 Installation

---

### 5.1 Safety Instructions



#### NOTE

Read this chapter thoroughly prior to commencing any work!



#### WARNING! EXPLOSION HAZARD!

In enclosed areas there is an increased risk of explosion when using a cutting torch or welding equipment!  
*Before use, check the level of gas and dust in the air.*



#### WARNING! EXPLOSION HAZARD!

The pressure tank may burst if the permissible working pressure is exceeded.  
*Observe and follow the documentation of the safety valve for detailed information.*  
*Do not use a safety valve under any circumstances whose pressure limit is higher than the permissible working pressure of the pressure tank.*



#### DANGER! MATERIAL THROWN AROUND!

By firing the Air Cannon, material may get thrown around, which may lead to fatal injuries.  
*Do not open any entry openings to the tank and do not step on it as long as the Air Cannons are filled up and in operation.*  
*If the Air Cannons have been installed in open tank, clear up the safety zone prior to firing.*

## 5.2

### Installing the MARTIN® Hurricane Air Cannon

The air cannon may be installed or operated only in conjunction with a nozzle and flange bracket. Both products are installed one after another.



#### NOTE

Read this chapter thoroughly prior to commencing any work!

Parts of this installation are described in this installation manual.

The remaining steps are described in the installation manual of the nozzles and flange brackets. The following table lists all steps for the installation. Each of the steps includes details that show where the relevant information can be found:

No.	Installation step	Instruction
1	Installing the flange plate	M3773
2	Installing the nozzles	M3773
3	Installing the Air Cannon	M3737
4	Connecting the Air Cannon to the compressed air supply	M3737

Tab. 1: Installation steps

#### 5.2.1

#### Installing the flange plate

Follow the instructions given in the installation manual on the flange brackets and nozzles for this purpose.

#### 5.2.2

#### Installing the nozzles

Follow the instructions given in the installation manual on the flange brackets and nozzles for this purpose.

## 5.2.3

### Joining the Air Cannon with the flange bracket

1. Join one flange with the outlet pipe and the other with the blow-off flange of the Air Cannon.
  - For outlet pipes with a thread, screw on the flange completely on to the outlet pipe. If necessary, secure the connection with spot welding after aligning the Air Cannon.



#### NOTE

The screw connection should not be welded completely.

- For smooth outlet pipes, push the flange on the pipe and make a continuous fillet weld.
2. Install a gasket between the flanges and join the flanges with screws, spring washers and nuts.

## 5.2.4

### Installing the securing cable



#### DANGER! LOADS FALLING DOWN!

The Air Cannon may fall down and lead to severe or even fatal injuries.  
*Secure the Air Cannon with a sufficiently strong and long wire rope.*



#### NOTE

Do not connect the Air Cannon rigidly with the construction. Otherwise, the pressure tank may not work and the Air Cannon may fail.

1. Weld the lock washer enclosed (Item A in Fig. 3) with a 6 mm fillet weld to the tank wall (B)..



#### NOTE

For silo characteristics other than steel, use appropriate fixing material accordingly.

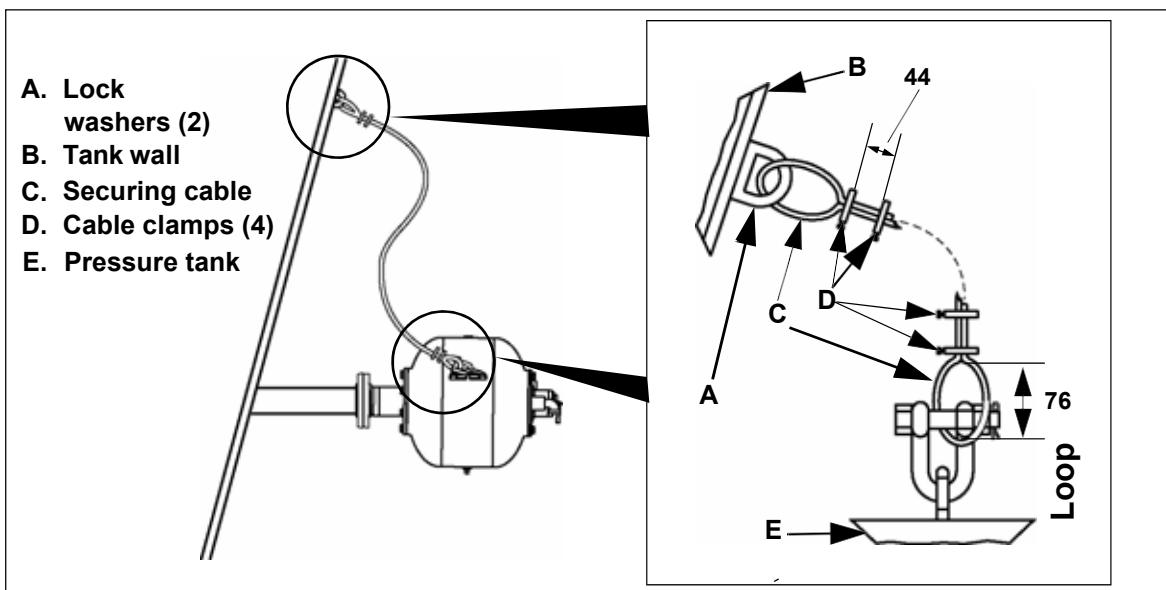

Fig. 3: Fastening the securing cable

2. Guide the securing cable (C) through the lock washer and form a loop of approx. 76 mm diameter.
3. Install a cable clamp (D) as close to the loop as possible and another cable clamp at a distance of about 44 mm.
4. Leave the free end with a length of at least 25 mm.
5. Tighten the screws alternately and uniformly with a torque of 20 Nm.



#### NOTE

Install the securing cable with a sag of 50 to 75 mm. For shortened cables, secure the ends of the cable appropriately against projecting wires (risk of injury).

6. Repeat the steps 2-5 at the Air Cannon tank.

## 5.2.5

## Connecting the Air Cannon to the air supply

**NOTE**

If the pressure in the process tank exceeds 0.3 bar, material may enter into the Air Cannon and contaminate valves or the pressure tank in this manner.

For higher values of process pressure, please contact Martin Engineering or an authorised dealer.

**NOTE**

Use appropriate sealants on all fittings.

Adequate pressure cannot be built up in the Air Cannon if there are leakages.

**NOTE**

Observe and follow applicable regulations regarding the use of safety valves and gauges.

1. Use appropriate sealants at all joints.
2. Remove the ½" BSP dust covers from the inspection connection (one or more) of the pressure tank.
3. Place the safety valve on the pressure tank. Please observe and follow the documentation of the safety valve to do this.
4. Check that all connections are tight and sealed.
5. Remove the countersunk hex. screw from the filling connection of the valve (see Fig. 8).

**CAUTION! DANGER OF INJURY!**

Impurities in the valve may lead to malfunctions of the Air Cannon. The exhaust air may lead to personal injuries.

*Align the pipe bend at the ventilation opening of the valve downwards as far as possible.*

*The opening for venting should not be closed and its diameter should not be reduced.*

**NOTE**

If necessary, Martin Engineering also supplies manually controlled valves, explosion-proof valves and complete solenoid valve cabinets.

If required, please contact Martin Engineering or an authorized dealer.

## 5.2.6

### Pneumatic installation of the 5/2-way solenoid



#### NOTE

Information on the installation of the solenoids as well as setting up and cabling the solenoid controller is given in the associated installation manual. You can procure electrical sensors, timers and controllers from Martin Engineering.

1. Install the pneumatic supply at the connection (1 Fig. 4, 5) on the rear side of the solenoid.
2. Install the filling line from the connection (1 Fig. 4, 5) to the connection (A Fig. 4, 5) of the valve.
3. Install the control line from connection (4 Fig. 4, 5) of the solenoid to the control connection (B Fig. 4, 5) of the valve.
4. Seal the connections (2 and 3, Fig. 5) with dummy plugs.
5. Install a silencer optionally at the connection (5 Fig. 4, 5) on the rear side of the solenoid.

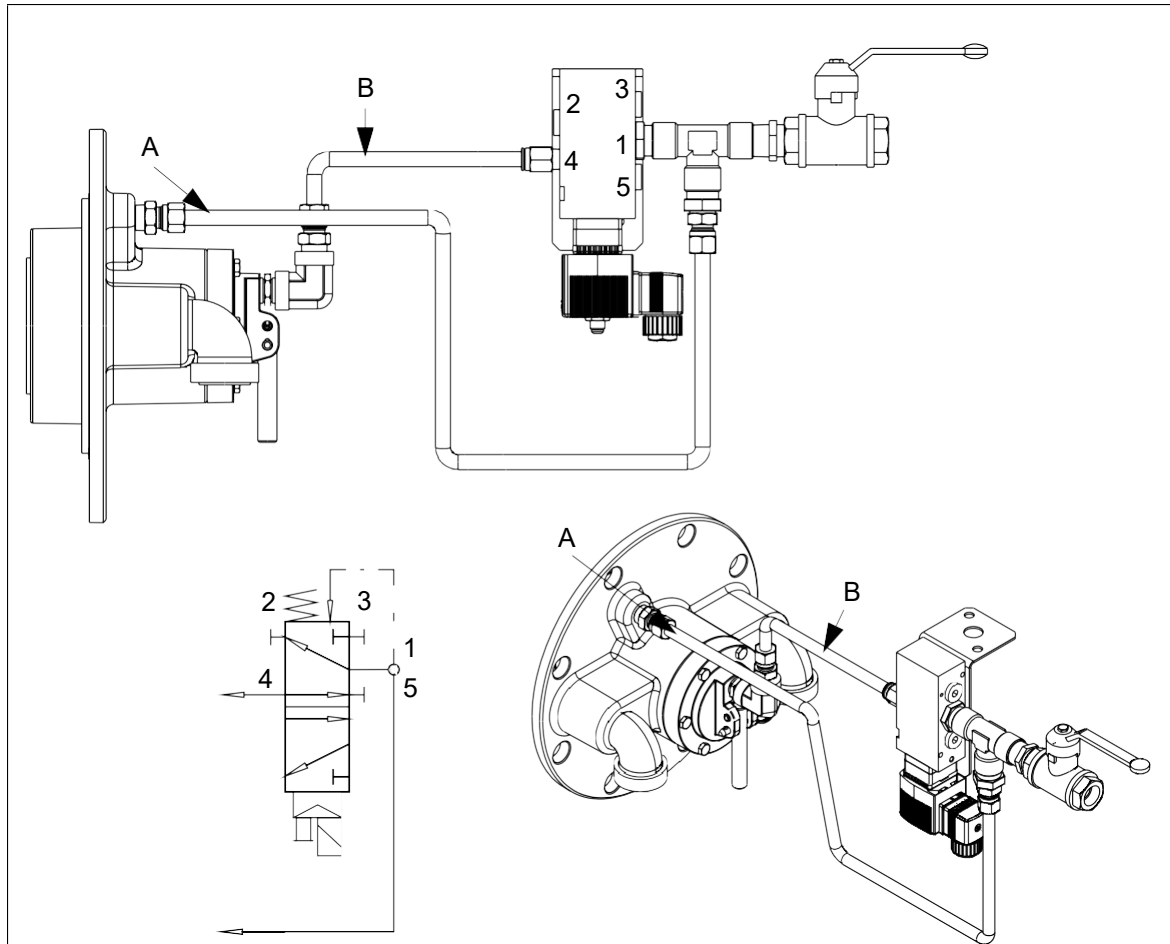

Fig. 4: Pneumatic connection of a 5/2-way valve - ISO-metric view



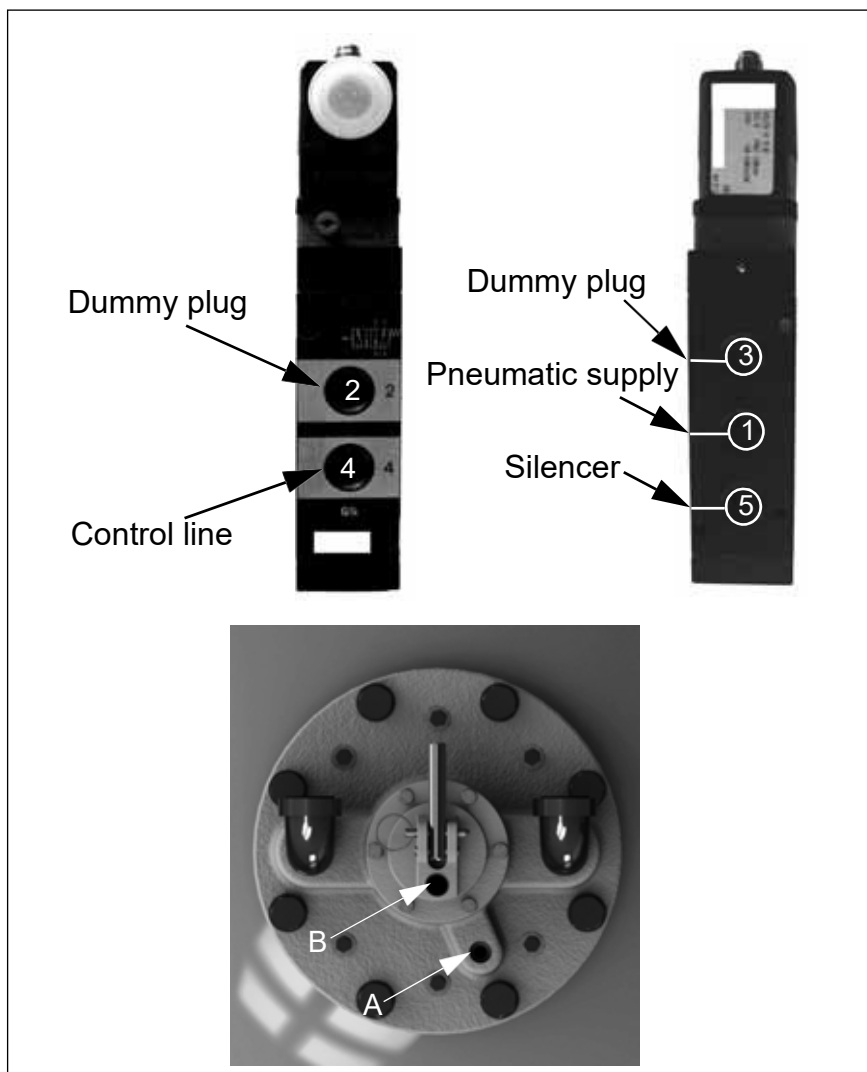

Fig. 5: Pneumatic connection of the 5/2-way solenoid

1. If it has been planned to have a solenoid valve controller, install this in accordance with the instructions furnished along with the controller



#### NOTE

The minimum pressure recommended for most applications is 5 bar, but it is also possible to use lower working pressure. Ensure that the Air Cannon is fed only with filtered and controllable compressed air.



## NOTE

Martin Engineering provides safety valves up to 10 bar. Before using a safety valve, check the permissible working pressure on the nameplate of the pressure tank. Do not use a safety valve under any circumstances whose pressure limit is higher than the permissible working pressure of the pressure tank. (Observe and follow the installation manual enclosed with the pressure tank supplied).



## WARNING!

The pressure tank may burst if the permissible working pressure is exceeded.

*The safety valve opens at pressure that is between 90% and 100% of the pressure set. Do not use a safety valve under any circumstances whose pressure limit is higher than the permissible working pressure of the pressure tank.*



## NOTE

When filling up the tank directly, care must be taken to ensure that the flow rate of the filling line does not exceed the maximum discharge rate of the safety valve. This is 1,650 standard litres/min. at 8 bar, and 1,960 standard litres/min. at 10 bar. If the feed rate exceeds the permissible discharge values, either the flow rate must be reduced or an appropriately designed safety valve must be used.



## NOTE

The minimum pressure recommended for most applications is 5 bar, but it is also possible to use lower working pressure. Ensure that the Air Cannon is fed only with filtered and controllable compressed air.

2. Lay pipes and cables safely and prevent anyone from stumbling on them. Fasten pipes and cables along their entire length in accordance with the regulations and standards applicable.

5.2.7 Solenoid valve cabinet

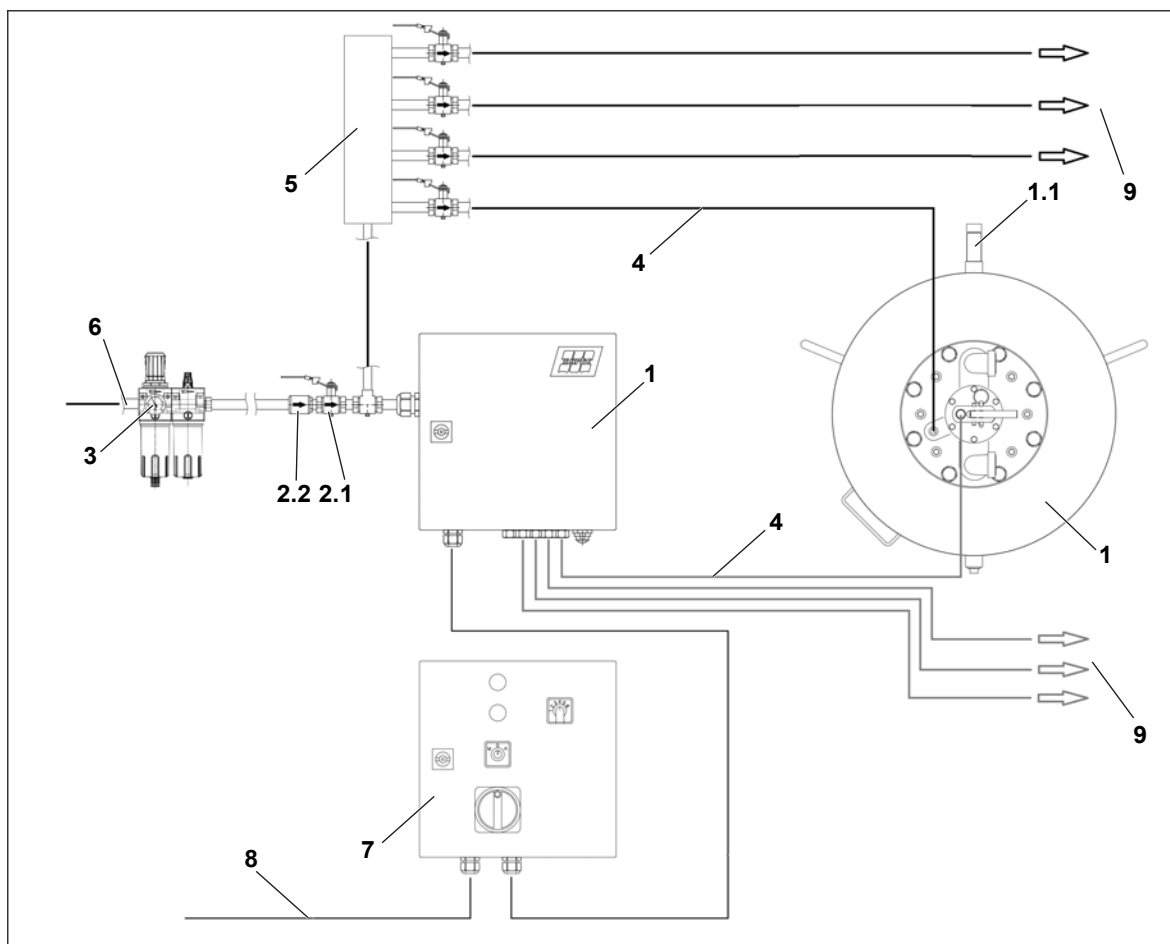

Fig. 6: Details on connecting the MARTIN® Hurricane Air Cannon

Item	Description	Function/Note
1	Air Cannon	---
1.1	Safety valve	Enclosed loose
1.2	Safety cable (n.d.)	Mount on the structure / enclosed loose
2	Solenoid valve cabinet (SVC)	Fire the air cannon
2.1	Ball cock with relief borehole	ventilates the air canon while locking
2.2	Non-return valve	prevents air from leaking out of the system in case of drop in pressure
3	Maintenance unit	Filter controller with oiler
4	Pneumatic line	Filling and control line
5	Distributor	Filling the air cannon
6	Compressed air supply	Min: 3 bar Max: 10 bar
7	Control system (if available)	Electrical control of the SVC (Solenoid Valve Cabinet)
8	Power supply / Start signal	from the higher level control system

Tab. 2: Parts List - MARTIN® Hurricane Air Cannon

Item	Description	Function/Note
9	Pneumatic lines for the following air cannons	---

Tab. 2: Parts List - MARTIN® Hurricane Air Cannon



**NOTE**

Use only solenoid valve cabinets that have been manufactured by Martin Engineering specially for Air Cannons. Other cabinets may possibly not provide the required feature or performance.



**NOTE**

The standard solenoid valve cabinets of Martin Engineering used have IP66 class of protection. They are not approved for use in explosive zones. If an explosion-proof solenoid valve cabinet is required, please contact Martin Engineering or their authorised dealer.

1. Specify the site for installing the solenoid valve cabinet.
2. Install the cabinet with the screw connections pointing downwards

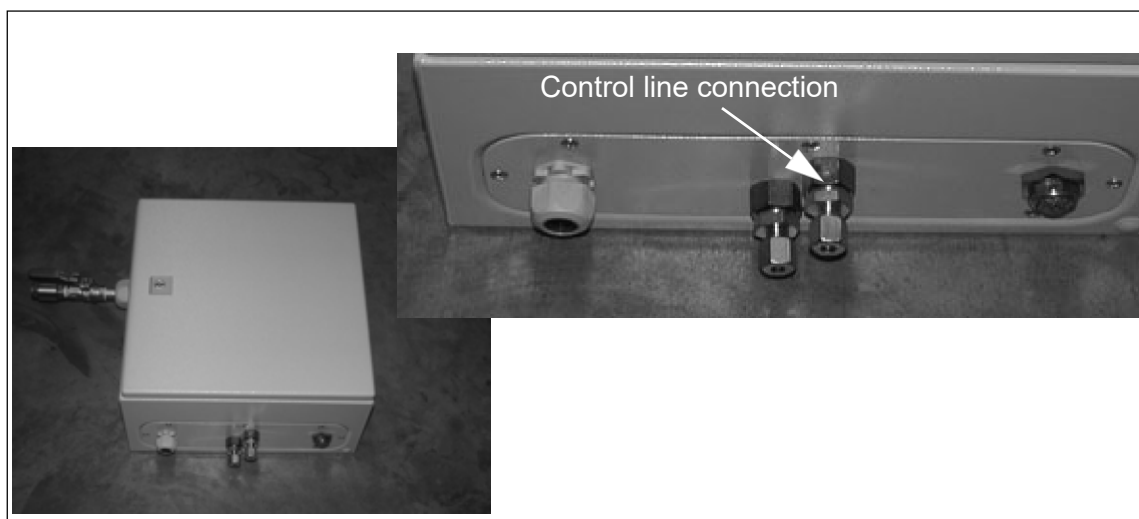

Fig. 7: Solenoid valve cabinet (Display for 2 Air Cannons)

3. Connecting the control lines to the solenoid valve cabinet:
  - fix the control line in the appropriate screw connection with screws or by pressing it in on the SVC.
  - lay the control line to the ventilation valve of the air cannon.
  - screw on the external filling line with the filler neck (A Fig. 8) of the valve cover.

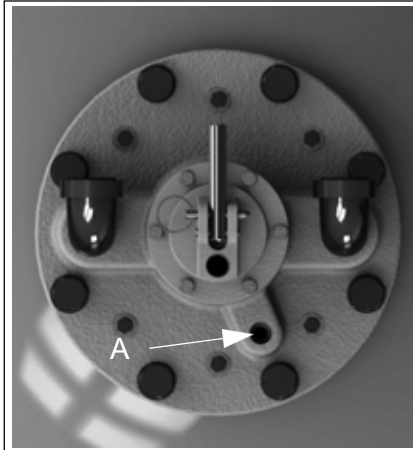

Fig. 8: Connection of the filling line at the valve

- Press the control line into the control connection (B, Fig. 9) of the ventilation valve.

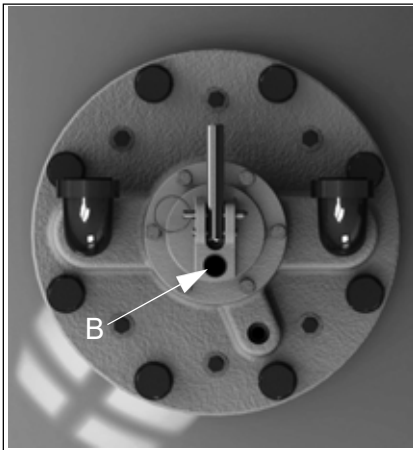

Fig. 9: Connection of the control line at the valve

4. Connect the maintenance unit at the entry of the solenoid valve cabinet. The feed line (1/2") may have any length as desired.



## NOTE

While installing, observe and follow the arrow of flow direction at the maintenance unit, non-return valve and ball cock.

5. (Optional) Fill the mist oiler with suitable pneumatic oil (For more information refer to the oiler manufacturer's documentation).
6. Adjust the oiler in such a manner that lubrication of the parts is identifiable.



Fig. 10: Maintenance unit (Example)

7. Seal connections with a suitable sealant.
8. Lay all pipes in such a manner that the risk of stumbling can be ruled out.

### 5.2.8

#### Electrical Installation of the solenoid valve cabinet

The electric installation should be done only by an electrician. All laws, standards and guidelines applicable to the company must be observed and followed. Earth electrical equipment in accordance with the regulations applicable.



#### NOTE

VDE-certified controllers as well as the accessories required (e.g. switches, timers and cables) for installing the solenoid valve cabinet are available with Martin Engineering.

Please observe and follow the installation instructions that are supplied along with the solenoid valve cabinet or the controller.

5.3

Attaching the warning label or the warning tag

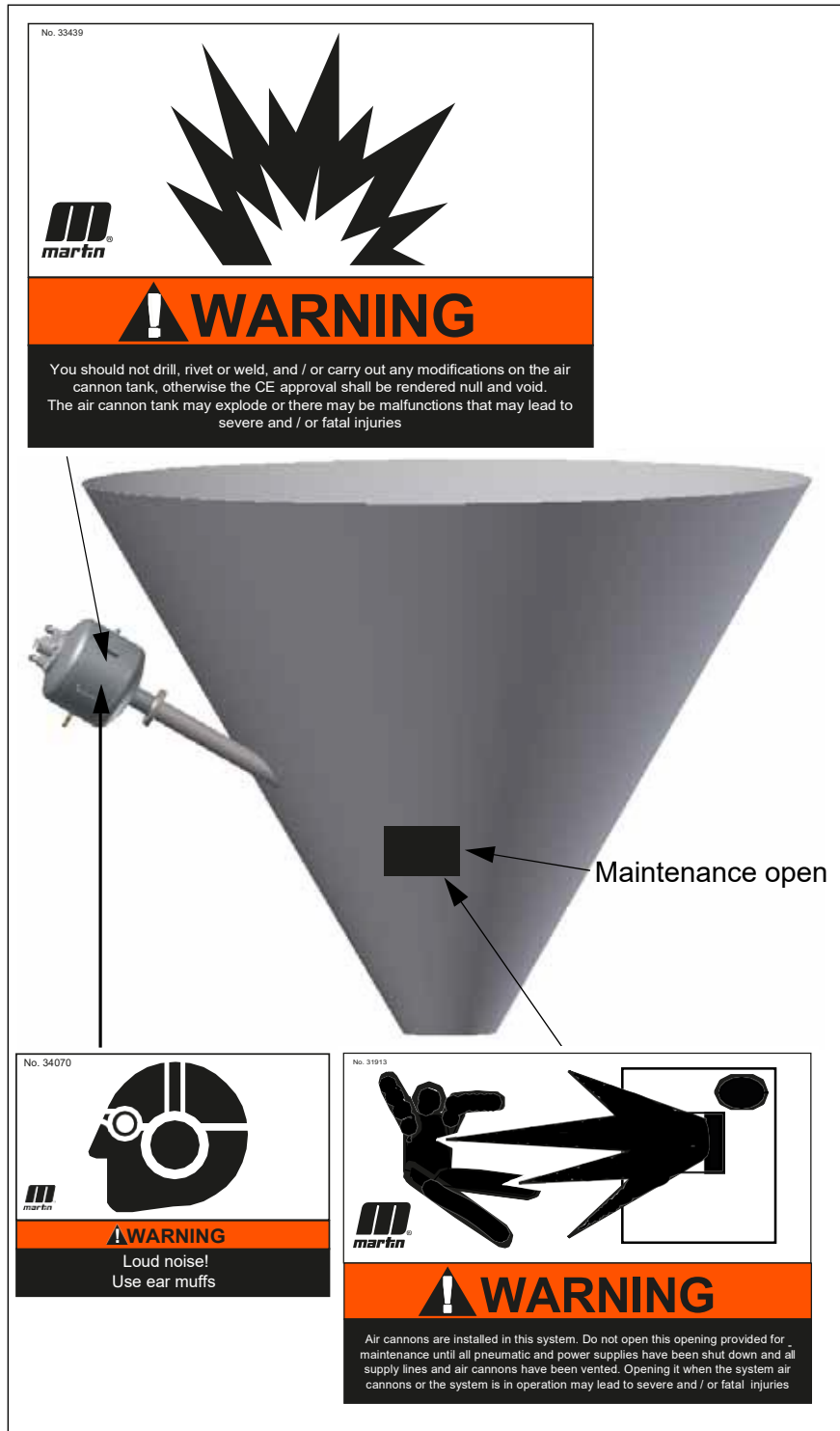

Fig. 11: Warning labels for MARTIN® Hurricane air cannon



## 5.4

### Test run

#### 5.4.1

#### Check the installation of the MARTIN® Hurricane air cannon



##### NOTE

Read through this chapter thoroughly before doing any work on the air cannon or the customer's compressed air system.

1. If there is more than one tank opening or connection, appropriate warning labels must be placed at each of them. Extra warning labels may be ordered out from Martin Engineering or an authorised dealer.
2. Vent all compressed air lines.



##### NOTE

Vent the Air Cannons one by one in order to avoid considerable pressure drop in the pneumatic system. The factory setting for opening the safety valve is 8 bars or 10 bars. (Observe and follow the technical documentation of the safety valve).

Martin Engineering provides safety valves up to 10 bar. Before using a safety valve, check the permissible working pressure on the nameplate of the pressure tank. Do not use a safety valve under any circumstances whose pressure limit is higher than the permissible working pressure of the pressure tank.



##### NOTE

The minimum pressure recommended for most applications is 5 bar, but it is possible to use lower working pressure. Ensure that the Air Cannon is fed only with filtered and controllable compressed air (see chapter 10.1 "Compressed air specifications")



## WARNING! EXPLOSION HAZARD!

The pressure tank may burst if the permissible working pressure is exceeded.

*The safety valve opens at pressure that is between 90% and 100% of the pressure set. Do not use a safety valve under any circumstances whose pressure limit is higher than the permissible working pressure of the pressure tank.*

3. Operate the compressed air supply to the air cannon.
4. If the Air Cannon does not get filled when it is put into operation the first time, please refer to Chapter 7, "Troubleshooting".
5. Check the Air Cannon installation for leakages. In case of leakages, refer to Chapter 7, "Troubleshooting".



## NOTE

When operating the air cannon for the first time or after every subsequent restart, a small amount of air escapes from the solenoid valve and the venting valve.



## DANGER! MATERIAL THROWN AROUND!

By firing the Air Cannon, material may get thrown around, which may lead to fatal injuries.

*Do not open any entry openings to the process tank and do not step on it as long as the Air Cannons are filled up and in operation. If the Air Cannons have been installed in an open tank, clear up the safety zone prior to firing.*

## NOTE

Wear ear muffs since there is a loud noise when the Air Cannon is fired.

6. Firing the Air Cannon: for Air Cannons with an electrical solenoid and external controller with the help of a signal via the controller (with a button, timer etc.) or by manual operation of the electrical solenoid. When the installation is done correctly, a signal is sent to the electrical solenoid and the Air Cannon selected is fired.
7. Fire the Air Cannon five times for testing it. After each discharge, wait for some time until the pressure tank gets filled up completely.
8. If the Air Cannon is working properly, it can be put into operation. Refer to Chapter 7, "Troubleshooting" if problems arise

**NOTE**

Make sure that the Air Cannon is always filled with compressed air. In this way, it is always ready for use and no material from the process can penetrate into it.

## 6

## Maintenance

## 6.1

## Safety Instructions

**NOTE**

Maintenance inspections should take place at least once a month. Depending on operational conditions, shorter maintenance intervals may be necessary.

**NOTE**

Read this chapter thoroughly prior to commencing any work.

**CAUTION! DANGER OF INJURY!**

Whipping pressure hoses can cause injuries and damage to property.

*Before beginning maintenance work the compressed air system should be vented and all pressure removed and then secured against inadvertent reactivation.*

*Display warning signs.*

**CAUTION! EXPLOSION HAZARD!**

While doing welding work on the pressure tank, it may explode as a result of flying sparks.

*Never weld damaged or leaky pressure tanks.*

*Defective parts must be replaced or repaired by Martin Engineering.*

*The Air Cannon should not be put into operation if the pressure tanks are damaged or not air-tight.*

*Observe and follow the standards and regulations applicable.*

**WARNING! DANGER OF INJURY!**

Before doing any work on the Air Cannon system, the power supply must be shut down and secured against being switched on inadvertently. Observe and follow the regulations and standards applicable.

*Display appropriate warning signs.*

*Switch off the Air Cannon system.*

## 6.2

### Regular Maintenance inspections

1. Check all connections of the Air Cannon system for leakage or signs of wear and tear. Seal any leaking connections and tighten the screw connections. Replace damaged or worn out screw connections.
2. Ensure that the bending radius of the hoses is larger than 60 mm and that all pipes and cables have been fastened and laid safely and securely. Repair any damages and fasten any lines that have not been fastened.
3. Check the function of the valve, the electromagnetic valve, the shut-off ball cock and the maintenance unit. Replace any defective parts promptly.
4. Check that the gauge is working. Clean the glass and check the legibility of the scale.
5. Check the safety valve: Please observe and follow the documentation of the safety valve to do this.
6. Check the securing cable: Ensure that the cable clamps are fixed and the components are not damaged or corroded.
7. Clean all warning labels. Replace warning labels that are no longer eligible immediately. Warning labels may be ordered out from Martin Engineering or an authorised dealer.

## 6.3

### Annual Maintenance or after 50,000 shots

1. Fire the Air Cannon in order to allow the air to escape from the pressure tank.
2. Pull at the ring of the safety valve to check that the Air Cannon is de-pressurized. Please observe and follow the documentation of the safety valve to do this.
3. Carry out all the regular maintenance work (refer to clause 5.2).
4. Remove the drain screw and allow any liquid there to drain off completely.
5. Seal the drain screw with a suitable sealant. Fix the drain screw once again into the pressure tank.



## CAUTION! EXPLOSION HAZARD!

While doing welding work on the pressure tank, it may explode as a result of flying sparks.

*Never weld damaged or leaky pressure tanks.*

*Defective parts must be replaced or repaired by Martin Engineering.*

*The Air Cannon should not be put into operation if the pressure tanks are damaged or not air-tight.*

*Observe and follow the standards and regulations applicable.*

6. Check the Air Cannon for corrosion, loose screws and bolts, as well as for defective welded seams. Tighten loose screws and repair all defective parts.
7. Check the pressure tank, valve, piston and nozzle for damage or impurities. Replace defective components or have them repaired by Martin Engineering.



## NOTE

Follow the M3747 maintenance manual for maintaining the valve.

8. Check the securing cable for wear and tear; in case of any signs of abrasion or damage, replace it.
9. In systems with an electronic controller, check the electrical cables and connections; replace any defective components or repair them in accordance with all application regulations and standards.

## 6.4 Replacement of the MARTIN® Hurricane Venting Valve

### 6.4.1 Dismantling the venting valve

1. Operate the main lever to discharge the Air Cannon:

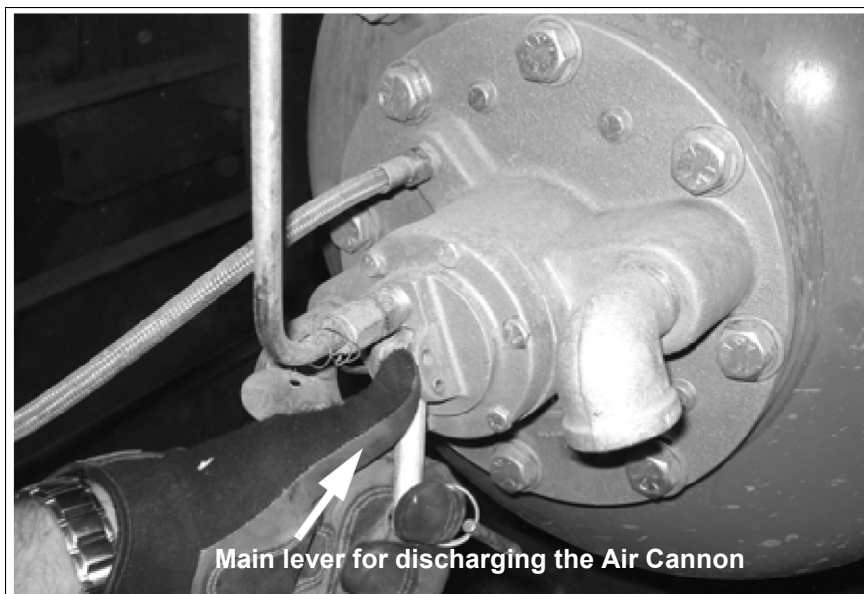

Fig. 12: Discharging the Air Cannon

2. Close the thermo safety shield (if available). If the blow-off port of the Air Cannon is open, ensure that there is adequate protection against the hazard of freely moving material and against risks in the blow-off region.



Fig. 13: Closing the thermo safety shield

3. Disconnect the compressed air lines from the pressure tank:

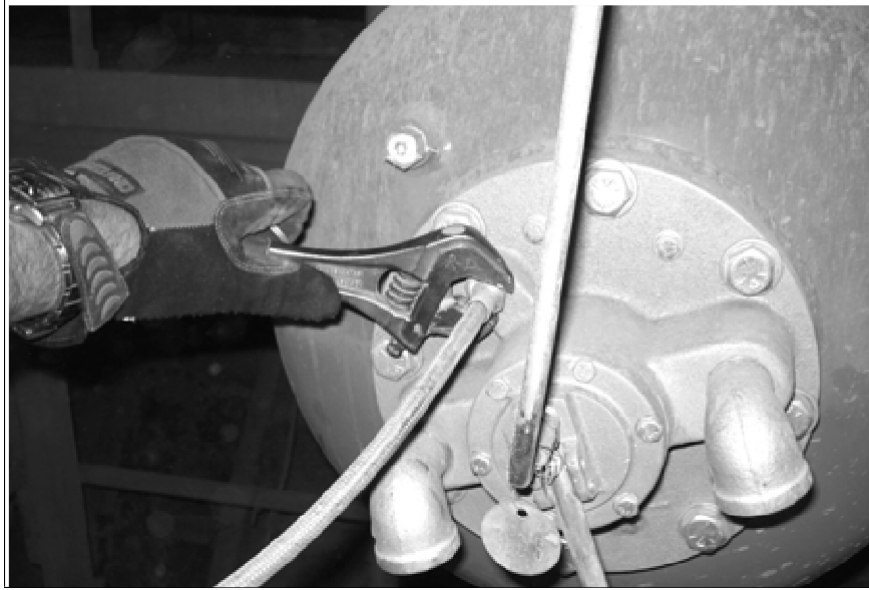

Fig. 14: Removing the compressed air line

4. Remove all eight screws of the valve



Fig. 15: Removing the screws of the valve

5. Remove the valve from the pressure tank; in case of O-rings that have dried up, using a small crowbar or something similar may be helpful. Take care to see that the sealing surfaces do not get damaged during de-installation.



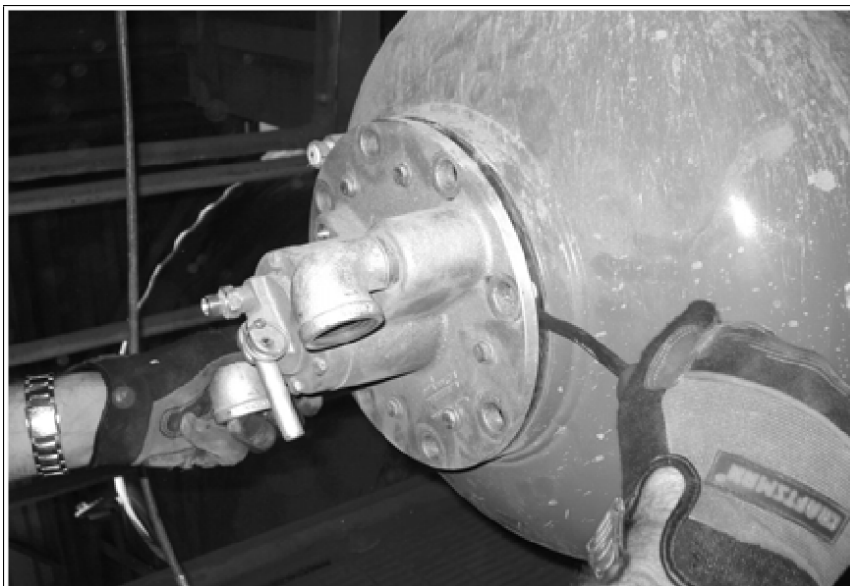

Fig. 16: Removing the valve

6.4.2

Installing the venting valve

1. Grease the O-ring slightly and insert it in the ring groove. Ensure that the O-ring has been placed cleanly in the groove, otherwise there is the risk that it may get damaged.



Fig. 17: Greasing the O-ring

2. Grease the O-rings in the discharge pipe lightly.



Fig. 18: Applying grease to the O-rings in the discharge pipe

3. Check the inside of the Air Cannon; ensure that the surfaces of the blow pipe are smooth and clean so that the O-rings are placed properly and hermetic sealing takes place.

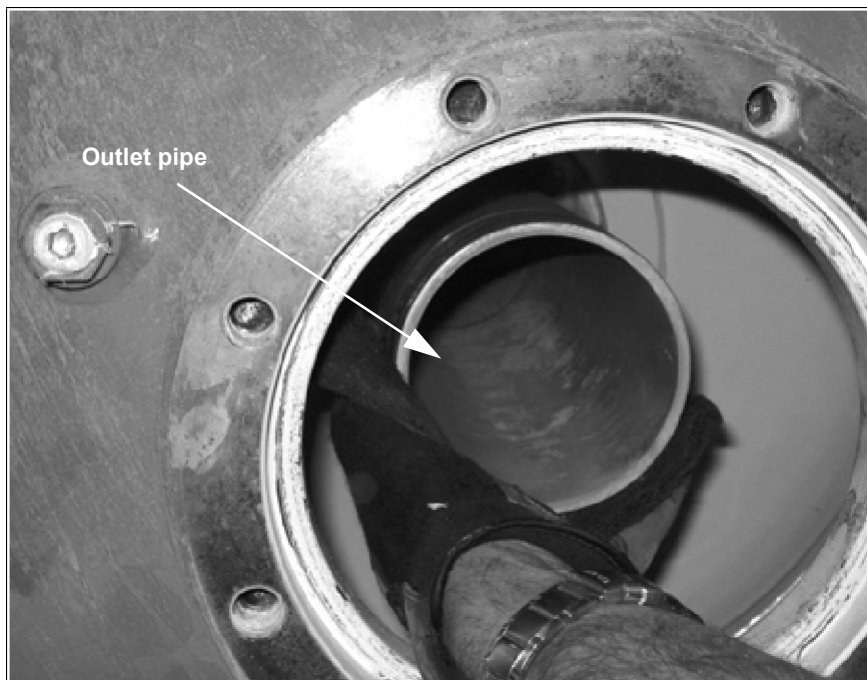

Fig. 19: Checking the Air Cannon

4. Place the valve on the outlet pipe, and ensure that the O-ring does not get squashed.



Fig. 20: Insert the valve

5. Insert eight screws with U-type washers and tighten them. Refer to Table 5 on page 54 for values of the tightening torque.



Fig. 21: Inserting the screws

6. Connect the compressed air line; ensure that you install them tightly and such that they are pressure-tight:

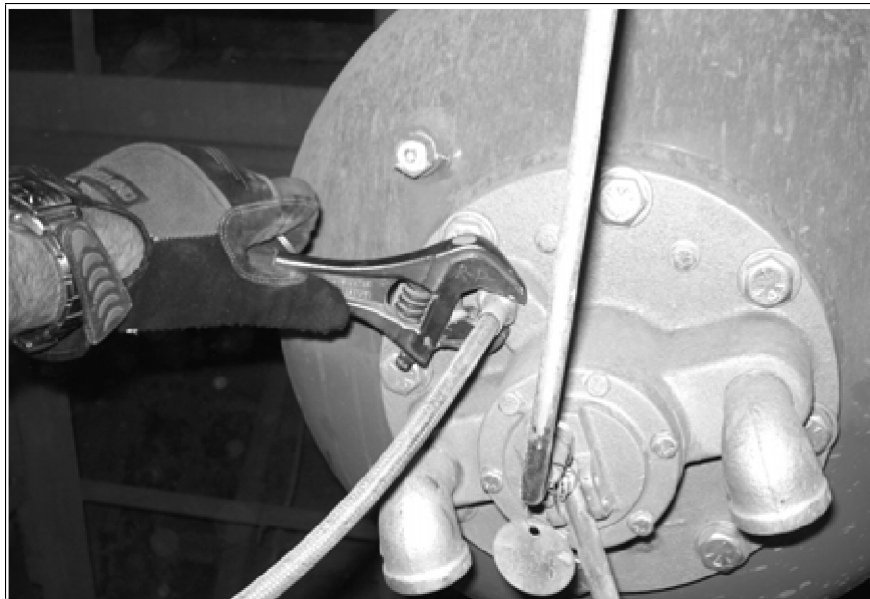

Fig. 22: Connecting the compressed air feed line

7. Put the thermo safety shield (if used) in the "Open" position:



Fig. 23: Opening the thermo safety shield

8. Apply pressure gradually to the Air Cannon; observe whether the seals or gaskets get deformed and leaks develop.
9. Wait until the Air Cannon is filled up and then fire it for the sake of testing.
10. If the shot works properly, the air cannon is ready for use once again.



#### NOTE

Observe the indication of the gauge while firing; the pointer should fall back to the "Zero" position immediately. The openings for venting should be aligned downwards so that no impurities can enter from there.

# 7 Troubleshooting

---

## 7.1 Safety Instructions



### NOTE

The air cannon can be used in different processes. Therefore faults can occur other than those listed here. In this case, Martin Engineering or one of its representatives can help with the positioning or with customized solutions.

## 7.2 Troubleshooting

Check the condition of all solenoids before doing any other repair work. Damaged solenoids, which can no longer be moved or have got jammed in one position, lead to symptoms that may be equivalent to the conditions or states listed below. Check the electrical connections to all solenoids.

The following tables contain the description of possible causes and remedies for problems that may occur under certain circumstances. If the remedial measures recommended do not solve the problem, please contact the Martin Engineering representative.:

Symptom	Cause	Corrective action
The Air Cannon does not get filled.	Compressed air supply	Ensure that the compressor is switched on and that the compressed air lines are under pressure.
	Ball cocks	Check whether the ball cocks at all Air Cannons are completely open.
	The maintenance unit is mounted incorrectly or it has not been adjusted properly.	The factory setting of the secondary pressure is 0 bar. Adjust the value desired by lifting and then turning the maintenance unit clockwise. Check the flow direction on the maintenance unit - see the marking.
	Solenoids	Check the connections - Refer also to section 5.2.6. Connection 1 = Inlet, Connection 4 = outlet, Connection 5 = ventilation,
	Tank plug is missing	Check whether all connections on the pressure tank have been sealed.
	Filling connection of the Air Cannon.	Check whether the filling connection to the compressed air supply has been connected.
	Pneumatic connections of the solenoids.	Check all pipe connections. Check for leaks. Check the direction of flow in the pipelines.
The Air Cannon is not fired.	Electrical connections of the solenoids.	Ensure that the electrical connections are proper and correct. Check the voltage. Check whether the signals are being sent.
	Pressure in the pressure tank.	Check the indication of the gauge.
The Air Cannon is not firing.	Control line	Check whether the control line is connected correctly to the Air Cannon and the solenoid.
	Venting connections of the Air Cannon.	Check both the 1" bends. They <b>SHOULD NOT</b> be sealed or reduced in diameter.

Tab. 3: Troubleshooting

# Troubleshooting

Symptom	Cause	Corrective action
The air cannon is not firing	The blow-off port is clogged: The Air Cannon is making stuttering noises while discharging and the gauge indicator is dropping only gradually or does not come down to zero.	Remove the blockage or clogging.
	The control line is not air-tight or clogged.	Check whether the compressed air line is too long (more than 60 m).
	The working pressure is too low.	Check whether the working pressure is 5 to 7 bars.
	The control signal acts for a very short time.	Ensure that the solenoid remains activated long enough for it to work properly (at least 1 second).
The air cannon is always under pressure	The gauge is not correct.	Ensure that the gauge drops to "Zero" in less than 0.5 seconds.
The Air Cannon fires but has no effect.	The manual thermo safety shield is closed.	Open the thermo safety shield.

Tab. 3: Troubleshooting



## 8 Storage, deinstallation, disposal

---

### 8.1 Packing and transportation

The products described here are packed and shipped by Martin Engineering.

The products may be transported solely in the Martin Engineering packaging.

The logistics company in charge of the shipment shall be responsible for any damage and/or loss.

### 8.2 Storage

To ensure optimal function of the product, Martin Engineering recommends storing its components in a dry place at room temperature where they are protected against direct sunlight.

The best storage conditions are at +0 °C to +30 °C and 60% relative humidity.

Martin Engineering guarantees that the stored products will remain fully functional for at least 2 years under the storage conditions specified here.

### 8.3 Deinstallation

The deinstallation is carried out in the reverse order of the installation (see Section 5.2.2)

### 8.4 Disposal

Assemblies and/or single parts of the Martin Engineering products must be professionally disposed of after usage as follows.

- Complete assemblies must be dismantled, sorted by material type, and separately disposed of.

Comply with all nationally and internationally applicable disposal regulations when disposing of the product.

## Part numbers

---

This section lists the product designations with their associated part numbers for the MARTIN® Hurricane Air Cannon and its accessories. Spare parts for accessories not listed here can be purchased from Martin Engineering or from one of its sales representatives.

Please always indicate the part numbers in every order.

### 9.1

#### Explanation of part numbers

##### MARTIN® Hurricane Air Cannon

38005-aaa-bbcde-fghj+E

<b>a</b>	<b>Tank size in litres</b>
<b>035:</b>	35
<b>070:</b>	70
<b>100:</b>	150
<b>b</b>	<b>Tank pressure range in bars (max.)</b>
<b>08:</b>	8
<b>10:</b>	10
<b>c</b>	<b>Tank temperature range in bars</b>
<b>D:</b>	-30 - +150
<b>E:</b>	-50 - +150
<b>d</b>	<b>Type of certification</b>
<b>C:</b>	CE Certification
<b>G:</b>	TR CU Certification
<b>e</b>	<b>Tank design</b>
<b>P:</b>	powder coated (RAL 2004)
<b>C:</b>	special paint C5M (RAL 2004)
<b>Z:</b>	galvanised
<b>f</b>	<b>Piston options</b>
<b>0:</b>	Dual seal piston
<b>1:</b>	Solid aluminium piston
<b>g</b>	<b>Additional option</b>
<b>0:</b>	-
<b>h</b>	<b>Additional option</b>
<b>0:</b>	-
<b>j</b>	<b>Additional tests</b>
<b>0:</b>	No tests
<b>1:</b>	50% fault-free testing of the welding seams on the tank

## 9.2

**Accessories**

- Martin® Thermal hood for air cannon valve cover:  
Part no. 41643-XX
- Martin® Air blast limiter: Part no. 41564-XXX-X

**NOTE**

A large number of nozzles and installation plates are available for Martin air cannon installations. They are described and specified in more detail in the installation instructions M3773.

## 9.3

**Components and retrofit sets for the control system of the compressed air supply**

- Solenoid valve set: Part no.: 41433-XXXXX.
- 1/2" Filter: Part no.: 41231-FR
- 1/2" Oiler: Part no.: 41231-OE
- 1/2" Air filter/controller/oiler: Part no.: 41231
- Pressure gauge attachment kit: Part no.: 34843-FR+E
- Martin® Solenoid valve cabinet:  
Part no. 41362-XXXXXXXX-XX
- Martin® Control system for air cannons:  
Part no. 41294-XXXX

## 9.4

**Spare parts**

- Safety valve (8 bar) Part no.: 21680+E
- Safety valve (10 bar) Part no.: 21680-10+E
- Air pressure gauge Part no.: 30437-G+E
- Safety cable kit part no.: 32271+E
- MARTIN® Hurricane valve  
part no.: 38071+E
- MARTIN® Hurricane / Tornado Exhaust valve conversion  
kit part no.: 38137-4
- 4" piston part no.: 38022
- 5/2-way solenoid valve Part no. 41380-XXXXX

9.5

MARTIN® Hurricane Air Cannon

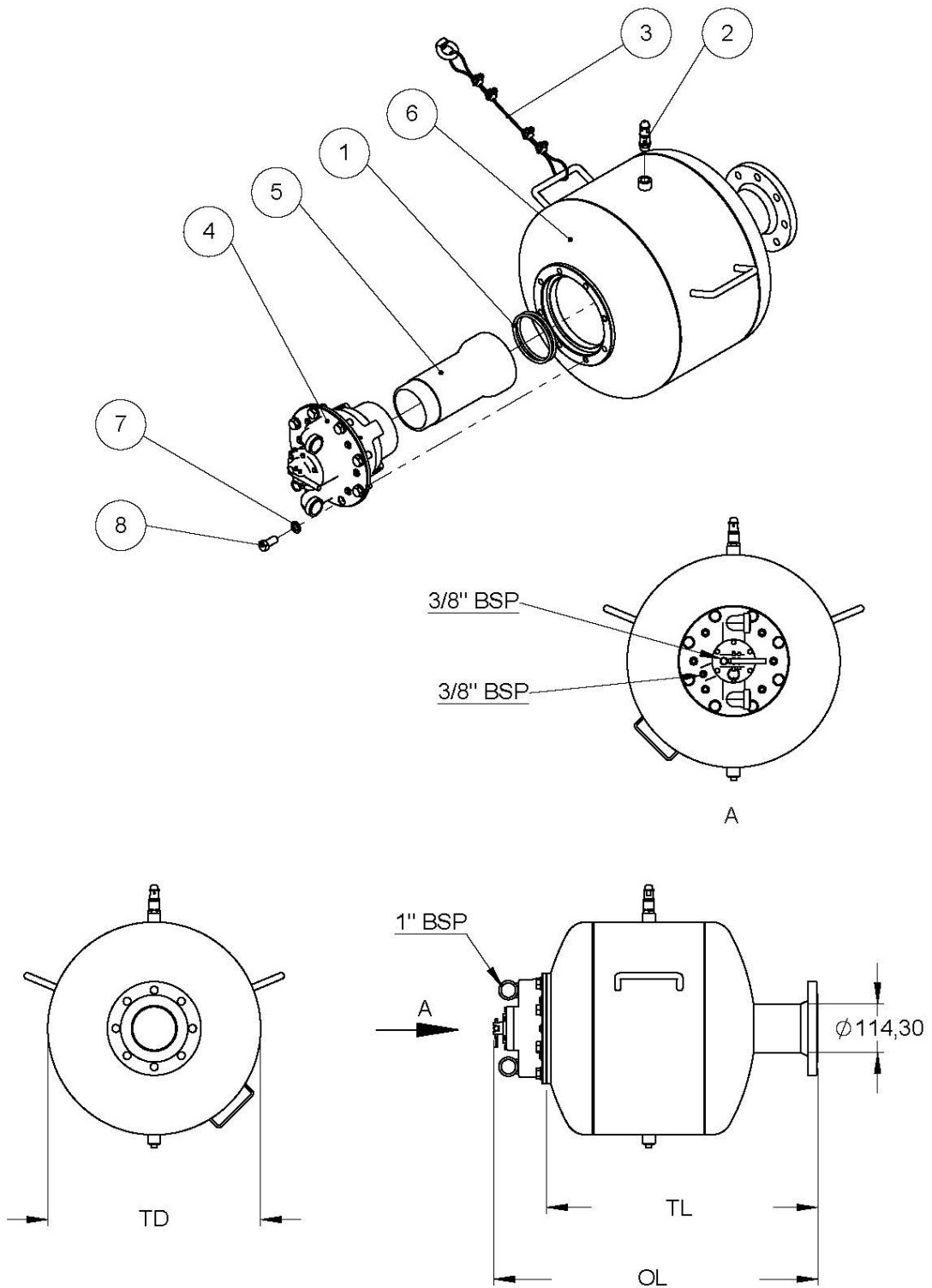

Fig. 24: MARTIN® Hurricane air cannon

\*BSP = British Standard Piping

Item / Pos.	Qty. / Anz.	Description / Beschreibung	P/N / Teile-Nr.
1	2	Silicon O-Ring / Silikonring	20771-S
2	1	Safety relief valve G1/2" (10 bar) / Federsicherheitsventil	s.C. / s.T.
3	1	Safety cable kit / Sicherheitskabelsatz	32271+E
4	1	Hurricane valve cap 4" / Entlüftungsventildeckel	38071-E
5	1	Inner pipe / Innenrohr	38602
6	1	Air cannon tank / Luftkanonenbehälter	s.C. / s.T.
7	8	Washer spring M16 - DIN 127, (1.0032) galv. / Federring	41090-16AZP
8	8	HHC screw M16 x 35 - DIN 933, (1.0032) galv. / Sechskantschraube	41081-16035BZP88

Part number / Teilenummer	Part no. Pos. / Teile Nr. Pos.	DIM			Weight / Gewicht
		TD	TL	OL	[kg]
38005-035-XXXXX-XXXX+E	38603-03510-XXX+E	400	686	560	55
38005-070-XXXXX-XXXX+E	38603-07010-XXX+E	500	763	637	70
38005-150-XXXXX-XXXX+E	38603-15010-XXX+E	600	959	833	104

Part number / Teilenummer	Part no Pos. / Teile Nr. Pos.
	2
38005-XXX-XXDXX-XXX+E	21680-10+E
38005-XXX-XXEXX-XXX+E	21680-10E+E

9.6

Part numbers of the MARTIN® Hurricane exhaust valve cover

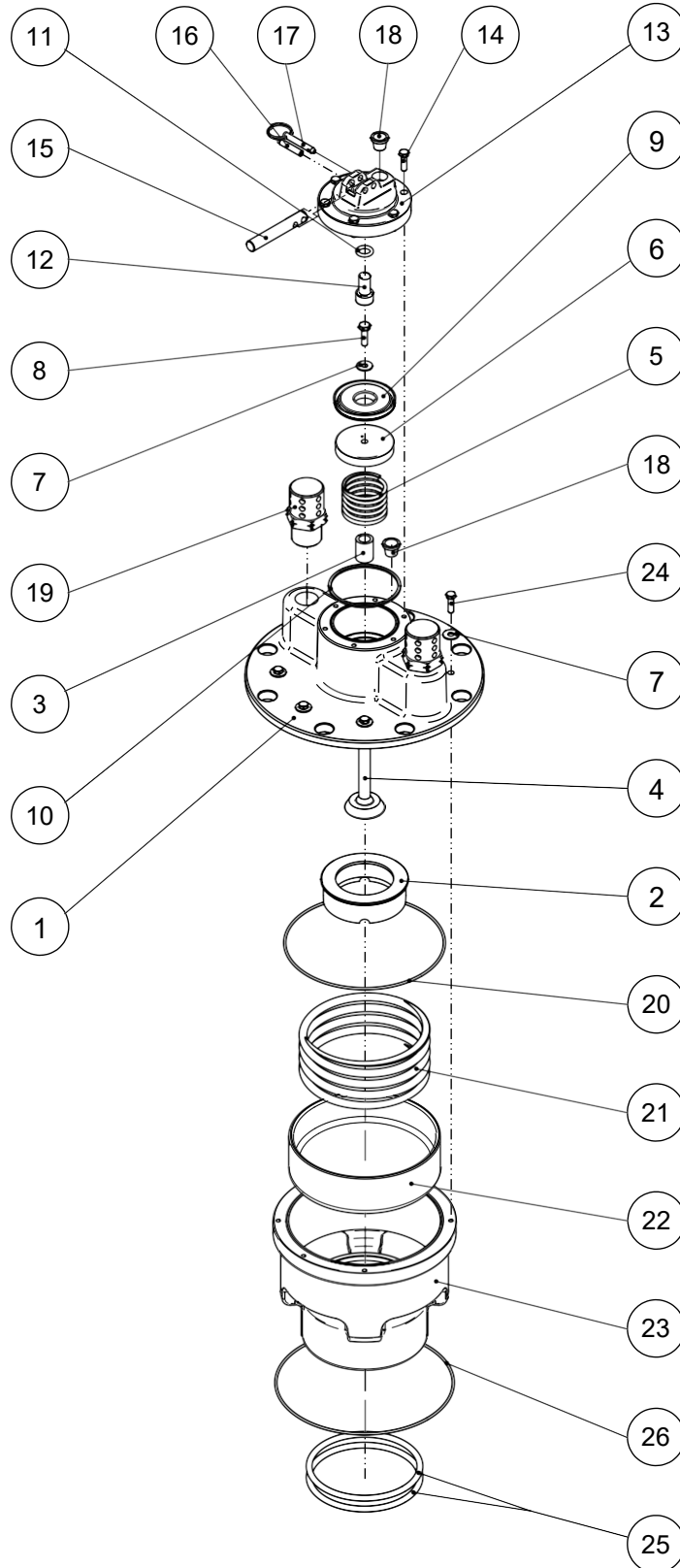

Fig. 25: Part numbers of the MARTIN® Hurricane exhaust valve cover

Item / Pos.	Qty. / Anz.	Description / Beschreibung	P/N / Teile-Nr.
1	1	Valve body cap 4" / Ventilgehäusedeckel	37775-H-E
2	1	VITON BUMPER 4.00 POS QEV	37793
3	1	Sleeve bearing bronze / Bronz buchse	37287-1
4	1	Air inlet valve / Lufteinlassventil	37790-B
5	1	Compression spring 1,9" / Druckfeder	34671
6	1	Valve body piston 4" & 6" / Ventildeckelkolben	38635
7	7	Washer compression 1/4" / Federscheibe	11521
8	1	Screw HHC 1/4" x 7/8" / Sechskantschraube	11891
9	1	Lip Seal Puck / Scheibe mit Dichtlippe	38634
10	1	O-Ring 2-7/8" / O-Ring	37794
11	1	O-Ring 1/2" / O-Ring	37795
12	1	Plunger stem / Stößel	37791
13	1	Valve body end cap 4" & 6" / Ventilgehäusedeckel Endkappe	37776-E
14	6	HHC Screw M6 x 25 / Sechskantschraube	37866
15	1	Handle / Hebel	37792
16	1	Spring pin 1/4" x 1-1/4", (1.4571) / Hohlspannstift	32403
17	1	Detent pin 1/4" / Sperrstift	37796
18	2	Plug plastic 3/8" / Plastikstopfen	11659
19	2	AIR CANNON DIFFUSER	39468-E
20	1	O-Ring 171,1mm ID x 2,6mm CS Viton / O-Ring	35078
21	1	Compression spring 4" / Druckfeder	35077
22	1	Piston 4" / Kolben	38022
23	1	Hurricane basket 4" / Korb	37897-E
24	6	HHC Screw M6 x 22 / Sechskantschraube	36530
25	2	Silicon O-Ring / Silikonring	20771-S
26	1	O-Ring 7-11/16" / O-Ring	38066

# Part numbers



## 10 Specifications

---

### 10.1 Compressed air specifications

The quality of the compressed air used must be equivalent at least to Class 5 of the DIN ISO 8573-1 standard, otherwise Martin Engineering cannot ensure proper and fault-free operation of the Air Cannon.

### 10.2 Values of tightening torque during installation

Screw size	Standard pre-load force	Tightening torque	Pre-load force
	[kN]	[Nm]	[kN]
M6	9	8	12
M12	35	70	40
M16	70	170	80
M20	110	300	120

Tab. 4: Values of tightening torque during installation - Strength category 8.8





### **Declaration of Incorporation in accordance with the Machinery Directive (2006/42/EC) Annex II B for the installation of an incomplete machine**

We, the company      **Martin Engineering,**  
In der Rehbach 14      Tel.: +49 (0)6123-97820  
D-65396 Walluf      Fax: +49 (0)6123-75533

declare herewith that the product mentioned below

Product designation:      **Air Cannon**  
of the make / type:      **Hurricane**  
with the serial number:      **not required**

complies with the following provisions:  
**EC Machinery Directive 2006/42/EC**  
**DIN EN 618 - Equipment and Systems for the Handling of Bulk Materials**

In particular, the following harmonised standards have been applied:

**DIN EN ISO 12100 Safety of machinery**  
Notified body:      **not required**

The information provided in the installation manual and technical documentation are in the original version with the named product.

The operation of this product is prohibited until it has been established that the system in which it is to be installed complies with the provisions of the EU Directive 98/37/EC and 2006/42/EC, in the amended form.

Date: 21/01/2010

Manufacturer's signature: Managing Director, Michael Hengl



# **PROBLEM SOLVED™**

## **USA (Headquarters)**

### **Martin Engineering**

One Martin Place, 61345 Neponset (Illinois), USA  
Tel. +1 (800) 544-2947; Fax +1 (800) 814-1553  
info@martin-eng.com; www.martin-eng.com

## **European subsidiaries**

### **Great Britain**

#### **Martin Engineering Ltd.**

8, Experian Way, NG2 Business Park,  
Nottingham NG2 1EP, Nottinghamshire, Great Britain  
Tel +44 115 946 4746; Fax +44 115 946 5550  
info@martin-eng.co.uk; www.martin-eng.co.uk

### **France**

#### **Martin Engineering SARL**

50 Avenue d'Alsace, 68025 Colmar Cedex, France  
Tel +33 389 20 63204; Fax +33 389 20 4379  
info@martin-eng.fr; www.martin-eng.fr

### **Russia**

#### **OOO Martin Engineering**

Ul. Bolshaya Dmitrovka, 23/1  
125009 Moskau, Russia  
Tel +7 495 181 33 43; Fax +7 499 720 62 12  
info@martin-eng.ru; www.martin-eng.ru

## **Germany (Main European branch)**

### **Martin Engineering GmbH**

In der Rehbach 14, 65396 Walluf, Germany  
Tel. +49 6123 97820; Fax +49 6123 75533  
info@martin-eng.de; www.martin-eng.de

## **Turkey**

### **Martin Engineering Turkey**

Yukarı Dudullu İmes Sanayi Sitesi, B Blok 205 Sokak No.6  
34775 Ümraniye İstanbul, Turkey  
Tel +90 216 499 34 91; Fax +90 216 499 34 90  
info@martin-eng.com.tr; www.martin-eng.com.tr

## **Italy**

### **Martin Engineering Italy Srl**

Via Buonarroti, 43/A, 20064 Gorgonzola (MI), Italy  
Tel +39 295 3838 51; Fax +39 295 3838 15  
info@martin-eng.it; www.martin-eng.it

Subject to technical modifications  
Quality management system certified by DNV - ISO 9001

