

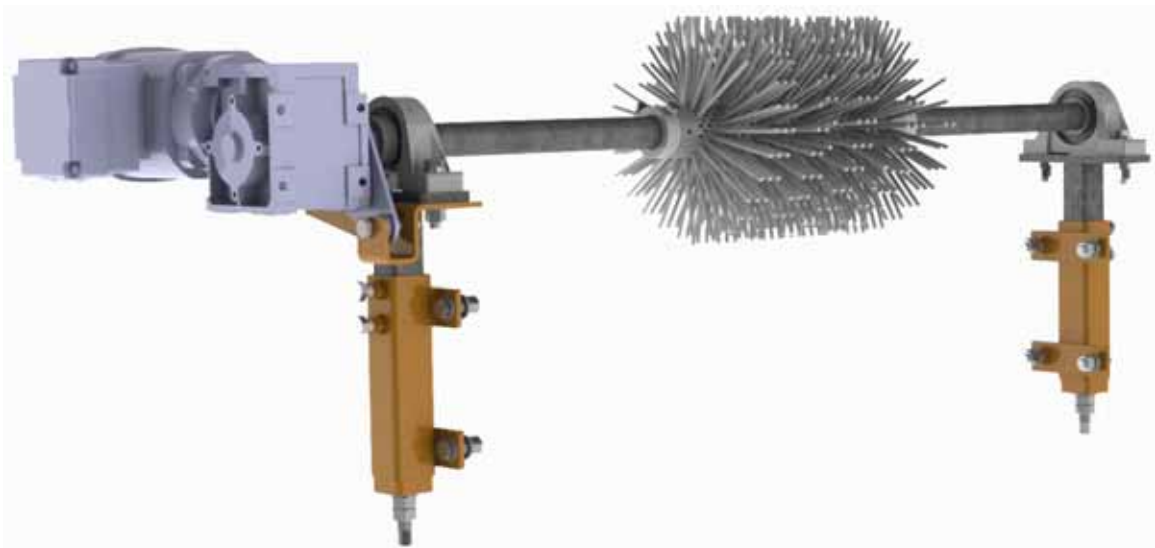

MARTIN[®] Brush Cleaner with external Motor



Installation Instructions
M3289UK

1	Table of contents	1
2	Introduction	3
2.1	Concerning these installation instructions	3
2.1.1	Scope	3
2.1.2	Copyright	3
2.1.3	Exclusion of liability	3
2.1.4	Reference to additional documents	4
2.1.5	Classification of the hazards	5
2.2	Intended usage	6
2.2.1	Conveyor systems with open transfer systems	6
2.2.2	Usage in explosion-protected areas	6
2.2.3	Restrictions on the use of the product	6
2.3	Occupational safety	7
2.3.1	Safety information, occupational safety	7
2.3.2	Duties of the owner-operator	7
2.3.3	Authorised personnel	7
3	Description of the product	8
3.1	Design and function	8
3.2	Type clarification	9
4	Preparing for the installation	10
4.1	Before the installation	10
4.1.1	Required materials and tools	10
4.1.2	Preparatory measures	10
5	Installation	11
5.1	Safety information	11
5.2	Installation process	12
5.2.1	Determination of the installation position	12
5.2.2	Installing the tensioner	16
5.2.3	Installing the cleaner	17
5.2.4	Electrical connection	19
5.2.5	Centring the mainframe beneath the conveyor belt	20
5.2.6	Aligning the mainframe parallel to the conveyor belt	22
5.2.7	Aligning the mainframe horizontally	23
5.2.8	Tensioning the secondary cleaner	24
5.3	Test run	26
5.4	Placement of warning labels and warning tags	28
6	Maintenance	29
6.1	Safety information	29
6.2	Weekly maintenance	29
6.3	Replacement of the cleaning elements	31
6.3.1	Lowering of secondary cleaner	32
6.3.2	Replace cleaning elements	34
7	Troubleshooting	37
7.1	Safety information	37
7.2	Troubleshooting	37
8	Storage, de-installation, disposal	39

Table of contents

8.1	Packing and transportation	39
8.2	Storage.....	39
8.3	De-installation	39
8.4	Disposal	39
9	Part numbers	40
9.1	Explanation of part numbers	40
9.2	MARTIN® Inspection doors	40
9.3	Installation manuals	41
9.4	Warning labels / Warning tags	41
9.5	Accessories and options	41
9.5.1	Inspection doors	41
9.5.2	Cleaning elements	41
9.6	Martin®Brush Cleaner.....	42
9.6.1	Technical Specification Angular Gear Motor	46
10	Declaration of Incorporation	47

2 Introduction

2.1 Concerning these installation instructions

Non-compliance with these installation instructions can result in loss of compensation for damage and/or warranty claims.

2.1.1 Scope

These installation instructions apply solely for the product described herein and are intended for those persons who install this product, commission it, and monitor its usage.

2.1.2 Copyright

The products described and these installation instructions are protected by copyright. Any reproduction without a licence will be prosecuted. All rights to the present document are reserved, including its reproduction and/or copying in any conceivable manner. Reprints of this document require the written consent of Martin Engineering.

The technical standard at the time of delivery of the product and its technical documentation are decisive as long as no other information is provided. The product and documentation are subject to technical changes without prior notification. Earlier documents then lose their validity. Martin Engineering's General Terms of Sales and Delivery shall apply.

2.1.3 Exclusion of liability

Martin Engineering guarantees the flawless function of its product in accordance with its advertising, the published product information, and its technical documentation. Martin Engineering shall assume no liability for efficiency and flawless function if the product is used for a purpose other than that described in the "Intended Use" section or for damage resulting from the use of accessories and/or spare parts which were not supplied and/or certified by Martin Engineering.

Martin Engineering products are designed for a long service life. They correspond to the relevant, current state of the scientific and technical art and have been thoroughly inspected before delivery. Martin Engineering also carries out continuous further development of products as well as product and market research.

Martin Engineering offers competent support whenever malfunctions and/or technical problems occur. Suitable actions are taken immediately. The warranty provisions of Martin Engineering apply and can be sent to you as needed.

2.1.4**Reference to additional documents**

Reference is made in these installation instructions to the following documents:

- Installation instructions for the MARTIN® inspection door
Publication no. M3127.
- Operating instructions for 3-phase motor DR.71-225, 315.
- Installation and operating instructions for gearboxes of type series R..7, F..7, k..7, S..7, SPIROPLAN® W

The following standards and directives were complied with in the preparation of these installation instructions:

- Machinery Directive (2006/42/EC)
- ISO/IEC Guide 37 "Installation instructions for products used by consumers", 1995 Edition
- DIN 1421 "Arrangement and numbering in texts", Edition 1983-01
- DIN/EN/ISO 12100 "Safety of machinery - General principles for design - Risk assessment and risk reduction", Edition 2011-03.
- DIN/ISO 16016 "Technical product documentation - Protection notices for restricting the use of documents and products", Edition 2007-12
- DIN/EN 60204-1 "Safety of machines - Electrical Equipment of Machines, Part 1: General requirements", Edition 2007-06
- DIN/EN 1083-1; -2 Power-driven brushes Part 1: Definitions and nomenclature" and "Part 2: Safety requirements", Edition 1997-07.
- DIN EN 82079-1 - Creation of user manuals - Structuring, content and presentation, Part 1 General principles and detailed requirements.

2.1.5

Classification of the hazards

**DANGER!**

Represents an immediately threatening danger which leads to serious bodily injuries or death if not avoided.

**WARNING!**

Represents a possibly hazardous situation which could lead to serious bodily injuries or death if not avoided.

**CAUTION!**

Represents a possibly hazardous situation which could lead to minor bodily injuries and/or property damage if not avoided.

**NOTE**

Contains comments about the installation and/or the product's usage to point out situations which cause neither personal injury nor property damage but include important information.

2.2**Intended usage**

The secondary cleaner can only be used for the cleaning of conveyor belts that are used for the transportation of bulk material.

It can be used on conveyor belts with a maximum belt width of 2000 mm and a maximum conveyor speed of 10 m/s.

Every other usage of this product is deemed as misuse. Please contact Martin Engineering customer service if you would like to use this product for a different purpose. We will be happy to assist you with the product configuration.

2.2.1**Conveyor systems with open transfer systems**

These installation instructions describe the installation on conveyor systems with encapsulated transfer systems. Various MARTIN® installation brackets can be used on open transfer systems.

Martin Engineering or one of its representatives can assist with the positioning or with special solutions in cases where the installation conditions are complicated such as insurmountable static components or a head pulley as the tensioning station.

2.2.2**Usage in explosion-protected areas**

This product may not be used in explosion-endangered areas.

2.2.3**Restrictions on the use of the product**

The product specified here may only be used within the scope of the specifications referred to above. Usage in a higher equipment protection category or under other operating conditions than those specified by Martin Engineering shall be deemed misuse and is only permitted if approved by Martin Engineering.

Martin Engineering or one of its representatives can assist you with the product configuration if you need to use this product for a different purpose.

2.3 Occupational safety

2.3.1 Safety information, occupational safety

These installation instructions must be read through in their entirety before work may be started on the product or on the conveyor system supplied by the customer.

The owner-operator must ensure that all installation, inspection and maintenance work is performed solely by trained specialists.

Work on conveyor systems and their accessories must always be performed during shut-down. The procedures described in the applicable installation instructions for shutting down the conveyor belt system must always be complied with.

All of the safety devices and safeguards must be reattached and/or made operational again immediately following completion of the work.

The installation must be carried out to completion before the system is started up. The flawless execution of all operating steps must be tested before the conveyor system can be started up again. Please observe all information on the installation and start-up of the product.

2.3.2 Duties of the owner-operator

This product's owner-operator must ensure that this product is installed, serviced and used solely by those persons who

- know the rules regarding occupational safety and accident prevention,
- were trained on using this product and have read and understood these installation instructions.

2.3.3 Authorised personnel

Personnel are considered authorised when they have suitable training and technical experience, can demonstrate knowledge of the applicable standards and guidelines, and are able to evaluate tasks in order to recognise critical situations at an early stage.

Operating, maintenance and installation personnel

Personnel are considered authorised when they have been trained on using the product and have read and understood these operating instructions in their entirety.

3 Description of the product

3.1 Design and function

The product is provided especially for cleaning difficult profile belts, e.g. chevron or slatted belts, and baked-on material. It is largely used as a single cleaning system; can however also be used in combination with a main cleaner.

The product installation is centred below the head pulley so as to feed the bulk solid back into the material stream. If by the use of this product, the material handling process is interrupted or the product contaminated, the user is responsible for taking any counter measures necessary.

Various bristle materials can be selected for a very large range of applications. For this, there are two different materials (polyester and brass) available that are specified in more detail in the technical data sheet. These are available for selection in three different bristle patterns (full, spiral-shaped and straight).

Only the same material and bristle pattern type can be used together. A mixture of different material and bristle pattern is not intended and must be checked in any individual case.



NOTE

An unfavourably or improperly installed product can disrupt the conveyor process or contaminate the bulk material to be transported.

The owner-operator is responsible for taking the required countermeasures.

In the case of applications with contaminants, Martin Engineering or one of its representatives can assist with the positioning or with special solutions.

3.2

Type clarification

There are three different bristle patterns available in the brushes for the product. A selection matrix for usage options is shown in the appropriate data sheet.



full trim



spiral-shaped

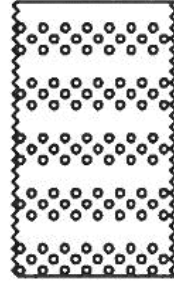

straight

4 Preparing for the installation

4.1 Before the installation

4.1.1 Required materials and tools

No special tools are required for the installation and maintenance of the product.

4.1.2 Preparatory measures



NOTE

Perform the inspections carefully and completely as described. The shipping company is liable for any transport damage! Please contact the shipper with any damage claims.



NOTE

An unfavourably or improperly installed product can disrupt the conveyor process or contaminate the bulk material to be transported.

The owner-operator is responsible for taking the required countermeasures.

In the case of applications with contaminants, please seek the advice of Martin Engineering or one of its representatives.

1. Inspect the delivery for the following conditions:
 - Is the delivery complete? Does the number of pallets/ crates/containers delivered match the number on the delivery note?
 - Do all of the transport packages appear to be undamaged? Does damage to the packaging exist which indicates damage to the product contained inside?
2. Always record any incompleteness or transport damage discovered in the delivery and have it confirmed by the shipper. All damaged products must be kept for inspection.
3. The delivery should include the following parts, depending on the scope of the order:
 - Brush cleaners incl. two tensioners.
 - Two Conveyor Products Warning Labels: Part no. 23395
 - Installation instructions
4. Report any missing or damaged parts to Martin Engineering or one of its authorised dealers.

5 Installation

5.1 Safety information



NOTE

Read this section completely before starting any kind of work!



WARNING! RISK OF INJURY!

Body parts and/or clothing may get caught and pulled in by rotating parts or by the moving conveyor belt.
Before any installation or maintenance work is carried out, ensure that all power sources to the conveyor belt system and its accessories are switched off and secured against unauthorised reactivation. Use warning signs!



WARNING! RISK OF EXPLOSION!

Increased risk when using a cutting torch or welding device in closed rooms!
Check the gas and dust content of the air before usage.



NOTE

The chute wall on which the angular geared motor is installed is designated in the following as the "operator side". The opposite chute wall is referred to as the "opposite side".

5.2

Installation process

5.2.1

Determination of the installation position

The position of the axle and the tensioning device of the secondary cleaner must be determined on both sides of the chute wall. In this process, the positions are therefore determined for where the shaft of the secondary cleaner is routed through the chute wall and/or where the tensioner is installed on the chute wall.

The secondary cleaner is delivered jointly with a tensioner. This is delivered as a work's dismantled unit and will be installed together with the secondary cleaner during the general installation.

The installation process for the secondary cleaner and the tensioner is described in the supplied installation instructions.

An overview of the installation steps follows:

No.	Installation step	Instructions
1	Determining the installation position	M3289
2	Installing the cleaner	M3289
3	Installing the tensioner	M3289
4	Tightening the cleaner	M3289

Tab. 1:

Various on-site conditions requiring different work steps are possible for the installation. These are presented as follows:

Installation on an encapsulated transfer system

- Follow the instructions given in Section 5.2.2.

Installation on an encapsulated transfer system with pre-existing installation openings and air line brackets for belt cleaners.

- Follow the instructions given in Section 5.2.3.

Installation on an open transfer system

- Use the equipment provided at the site to comply with the dimensions for correct installation.

**NOTE**

Martin Engineering recommends installing a MARTIN® inspection door for the purpose of better accessibility for maintenance and repairs.

**NOTE**

The secondary cleaner should ideally be installed near a head pulley or a counter-pressure roller. The clearance should not be more than 200 mm.

**NOTE**

The installation position is to be so selected that sufficient space is available for the installation of the MARTIN® brush cleaner. This distance should lie at least 350 mm outside the chute wall on the operator side and at least 100 mm on the opposite side.

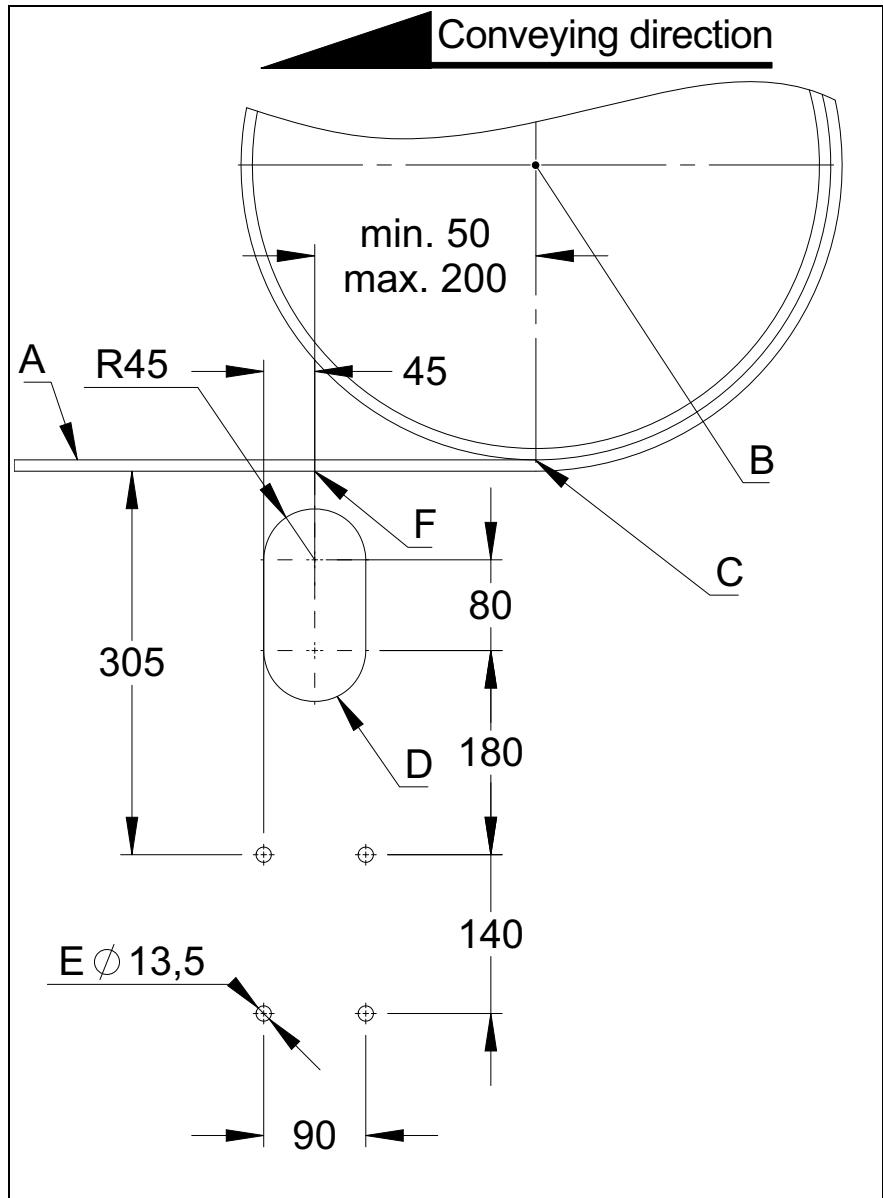

Fig. 1:

Pos.	Description
A	Conveyor belt
B	Centre point of the driving drum
C	Exit point of the conveyor belt from the driving drum
D	Slot
E	Installation holes in the tensioner
F	Position of the brush ends of the conveyor belt cleaner

1. Deactivate the conveyor system and all accessories before starting the installation work and secure them against inadvertent reactivation.
2. Mark the vertical and horizontal centre line of the driving drum on the operator side of the chute wall to determine the centre point (B, Fig. 2) of the driving drum. Extend the vertical centreline to determine the point C.
3. Mark a position (F, Fig. 2) at a distance from 50 to no more than 200 mm in the conveying direction (A, Fig. 2) from the point at which the belt leaves the head pulley (C, Fig. 2).
4. Draw a vertical line at this position (F, Fig. 2) going downwards at a right angle to the conveyor belt.
5. Use the dimensions from Figure 2 to mark the installation holes for the tensioner.
6. Create the slot-shaped cut-out and installation holes as shown in Figure 2.
7. Repeat steps 1 to 6 on the opposite side of the chute wall.

5.2.2

Installing the tensioner

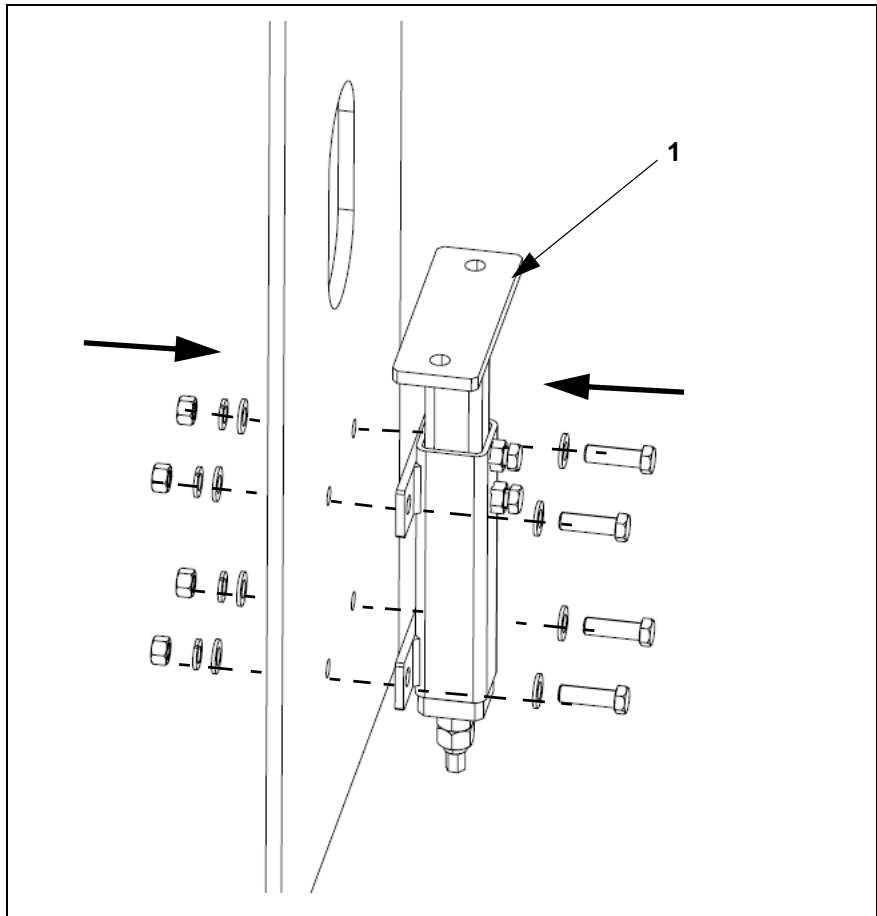

Fig. 2:

1. Attach the tensioner (1, Fig. 3) to the chute wall using the installation holes shown in Fig. 2
2. Repeat step 1 on the opposite side.

5.2.3

Installing the cleaner



WARNING! RISK OF INJURY!

The secondary cleaner is heavy and can cause serious injuries if it is dropped during lifting or moving.

Always use a suitable lifting device or engage the help of several persons when lifting the brush cleaner. Do not stand under hanging loads.



NOTE

Check the oil level in the angled gearbox of the motor before installing.

Observe the information in the manufacturer's documentation supplied with the device.

1. Fix the pillow block (3, Fig. 4) on both sides of the main shaft (2, Fig. 4) .

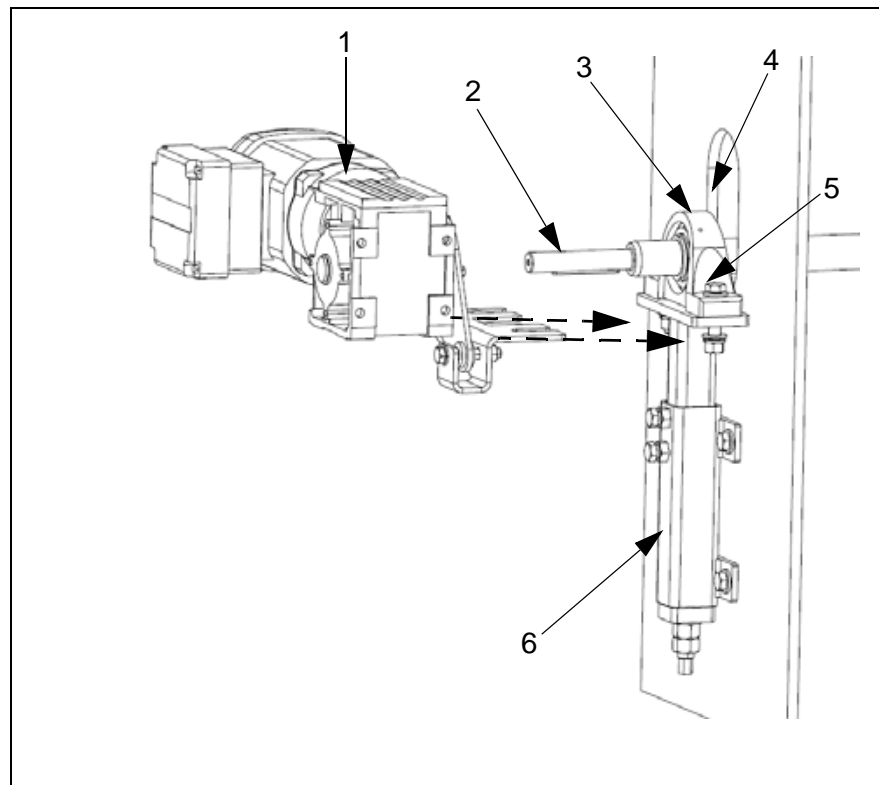

Fig. 3:

2. Slide the main axle (2, Fig. 4) through the two slots (4, Fig. 4) in chute wall.
3. Secure the pillow blocks (3, Fig. 4) using the bolts (5, Fig. 4) to the tensioners (6, Fig. 4).
4. Insert the feather key into the axle, if not already done.

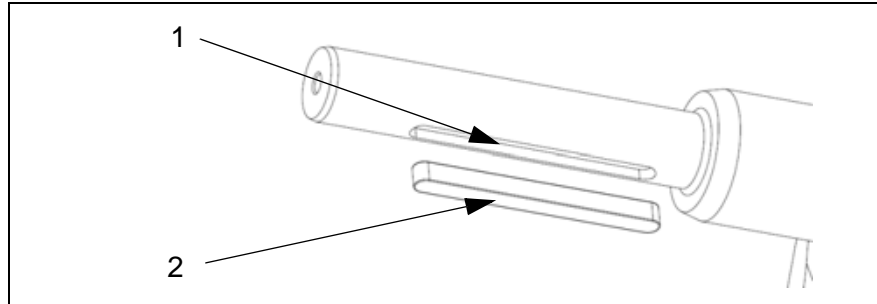

Fig. 4:



NOTE

Make sure that the feather key (2, Fig. 5) lies in the keyway (1, Fig. 5) of the axle.

5. Push the angled gearbox motor with mounting plate for motor torque support (1, Fig. 4) onto the shaft.



NOTE

The mounting plate must be installed from below onto the tensioner. The angled gearbox motor should always be placed on the shaft flush with the conveyor belt.

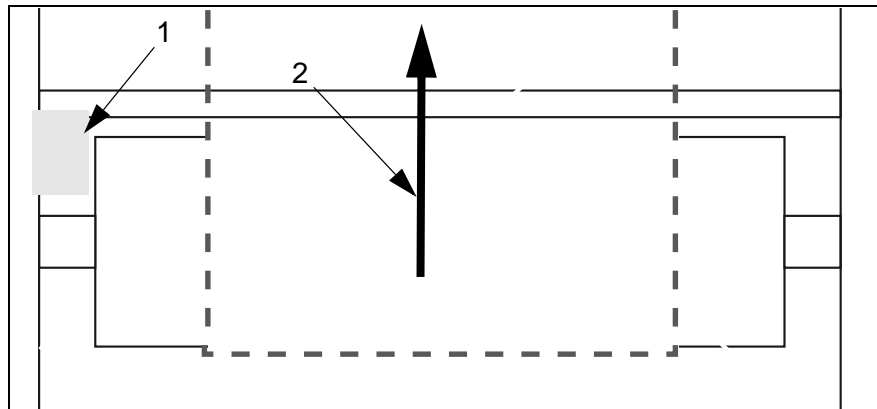

Fig. 5:



NOTE

The angled gearbox motor (1, Fig. 6) can only be mounted in the transport direction (2, Fig. 6) on the left side, a changeover to the right side is not possible.

6. Fix bolts (4, Fig. 4) of the pillow block on both sides with the nuts.

5.2.4

Electrical connection

The electrical installation may only be performed by an electrician. Comply with all laws, standards and directives which are applicable for the company. Earth the electrical equipment in accordance with the applicable regulations.



NOTE

Observe instructions in the manufacturer documentation on making electrical connections!

Observer the installation instructions and wiring diagrams supplied with the product. The angled gearbox motor must run such that the cleaning elements move in the opposite direction to that of the conveyor belt.

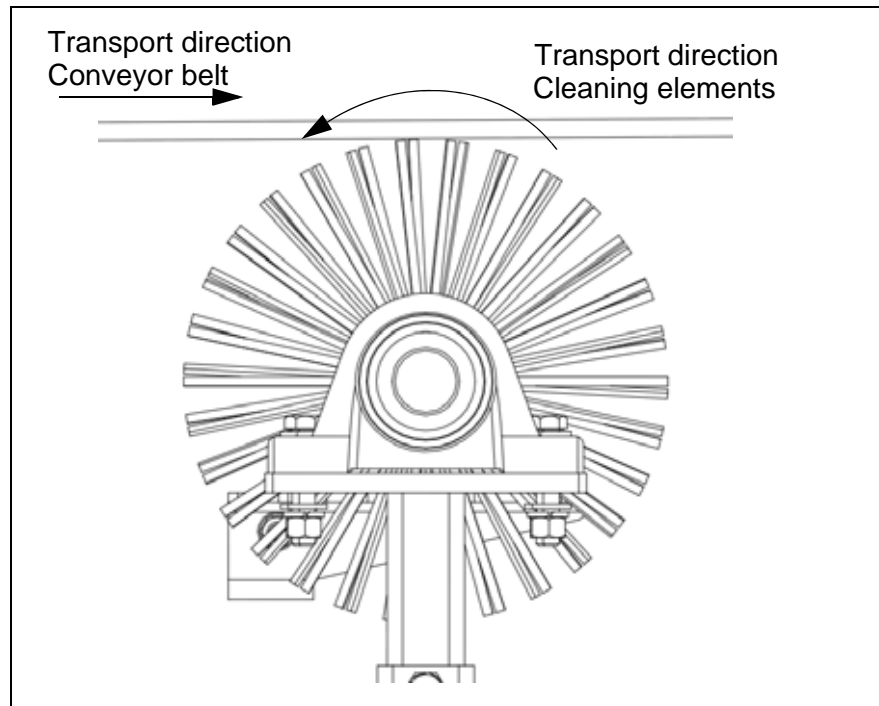

Fig. 6:



NOTE

Check the rotational direction of the cleaning elements before commissioning!



CAUTION! RISK OF DAMAGE!

Off-track running can cause damage to the conveyor belt edge and/or the cleaning elements.
Alignment of the secondary cleaner in accordance with the following instructions.



NOTE

The following displays are examples and can differ from the secondary cleaner actually used.

5.2.5

Centring the mainframe beneath the conveyor belt

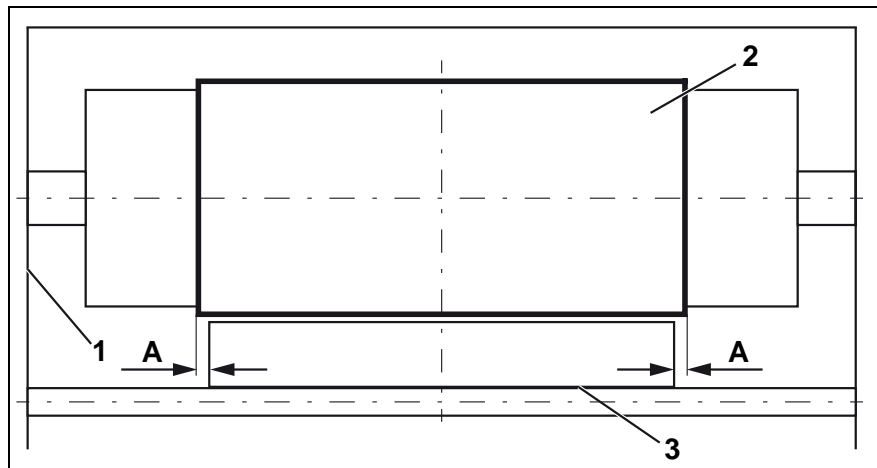

Fig. 7:

Pos.	Description
1	Chute wall
2	Driving drum
3	Cleaning elements

Tab. 2: Centring the secondary cleaner beneath the conveyor belt

1. Measure the clearances (A) and (B) between the edge of the cleaning elements and the conveyor belt edge.



NOTE

The conveyor belt must protrude around 50 to 100 mm from the left and right sides. The cleaning elements must be centrally aligned beneath the conveyor belt.

If these are not the same, the brush elements will shift on the main axle.

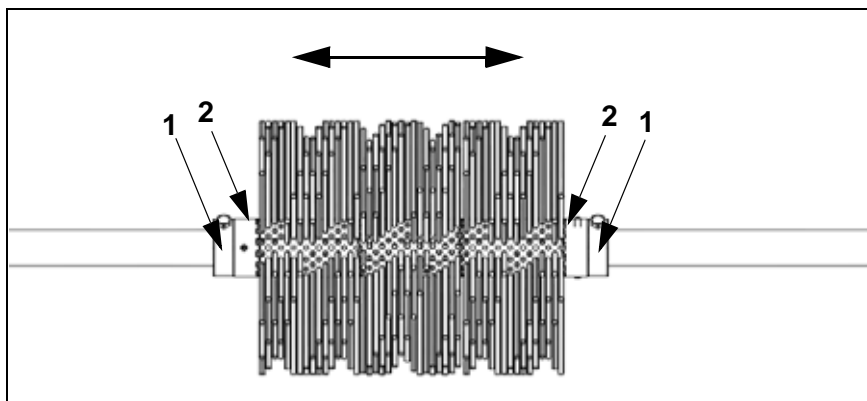

Fig. 8:

2. Loosen locking collar (1, Fig. 9) and adjusting ring (5, Fig. 9) on both sides.
3. Shift the cleaning elements so that clearance A is equal to clearance B.
4. Tighten adjusting ring (5, Fig. 9) and securing ring (1, Fig. 9) on both sides.

5.2.6

Aligning the mainframe parallel to the conveyor belt

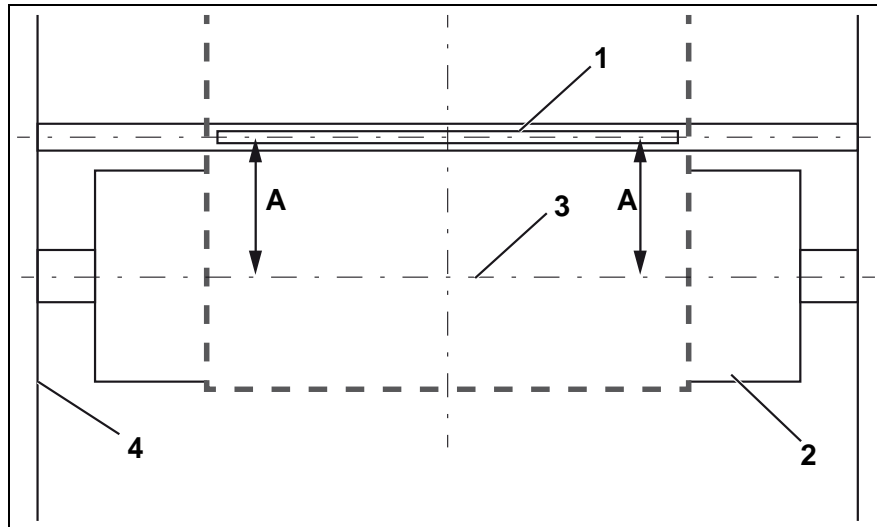

Fig. 9:

Pos.	Description
1	Plan view of cleaning elements
2	Driving drum
3	Driving drum axis
4	Chute wall

Tab. 3: Top view of aligning cleaning elements parallel to conveyor belt

1. Measure the clearance on both sides between the mainframe and the head pulley or counter-pressure roller.



NOTE

The measurements must be the same on both sides. If not, the tensioners must be re-positioned.

5.2.7

Aligning the mainframe horizontally

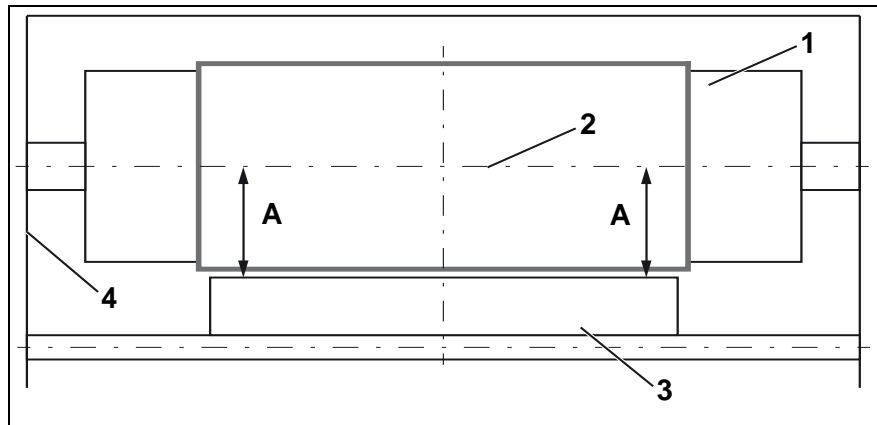

Fig. 10:

Pos.	Description
1	Driving drum
2	Driving drum axis
3	Cleaning elements
4	Chute wall

Tab. 4: Aligning brush cleaner horizontally

1. Align the mainframe horizontally with respect to the head pulley and check whether the bristles rest evenly on the conveyor belt.
2. Tighten the tensioner clamping screws.



WARNING! RISK OF INJURY!

The mainframe may not protrude more than 10 mm beyond the chute wall. Otherwise there is a danger of injury from the rotating shaft.

The shaft can only be shortened on the drive-facing side and not on the drive side.

Once the dimensions are correct and the secondary cleaner aligned, this can be attached accordingly. If this is not the case, then the mainframe must be reinstalled or repositioned.

5.2.8

Tensioning the secondary cleaner



NOTE

Perform the following steps carefully so that the MARTIN® brush cleaner achieves the desired cleaning result.



CAUTION! RISK OF DAMAGE!

Excessive or uneven tightening of the conveyor belt cleaner on the conveyor belt can cause material damage.

Only adjust conveyor belt cleaner according to specifications and also ensure that the adjustments on both sides are the same.



NOTE

After the installation, the secondary cleaner must be adjusted to the conveyor belt. In this, the cleaning elements should not be pressed more than 3-4 mm against the conveyor belt.

1. Loosen the clamping screws (1, Fig. 12).
2. Loosen the lock nut (4, Fig. 12).
3. Loosen the securing nut (2, Fig. 12).



NOTE

To avoid canting, both tensioners should be moved simultaneously.

4. Turn the adjusting screw (3, Fig. 12) anticlockwise till the cleaning elements are pressed against the conveyor belt.

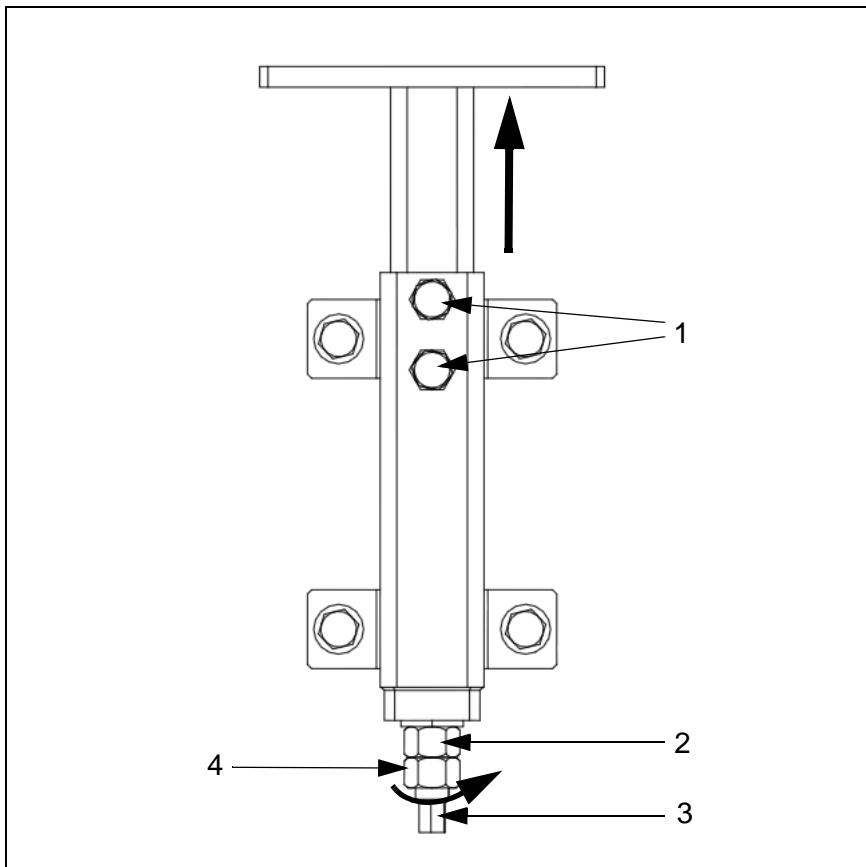

Fig. 11:

Pos.	Description
1	Clamping screw
2	Securing nut
3	Adjusting screw
4	Lock nut

Tab. 5: Description of nuts and screws

5. Repeat working steps on the opposite side.
6. If the cleaning elements are in the correct position, tighten the clamping screws (1, Fig. 12).
7. Tighten the securing nut (4, Fig. 12).
8. Tighten the lock nut (2, Fig. 12).

5.3

Test run



NOTE

Read through this section completely before starting any work on the belt cleaner or on the customer's conveyor system.



CAUTION! FLYING OBJECTS!

Forgotten tools or installation parts can fall off of the running conveyor belt and cause minor injuries and property damage. *Always remove any tools from the installation site and conveyor belt upon completion of the installation work before switching on the power supply.*



WARNING! RISK OF INJURY!

Body parts and/or clothing may get caught and pulled in by rotating parts or by the moving conveyor belt. *Before any installation or maintenance work is carried out, ensure that all power sources to the conveyor belt system and its accessories are switched off and secured against unauthorised reactivation. Use warning signs!*

1. Thoroughly clean the external chute wall on the operator side above the tensioner. Affix Conveyor Products Warning Labels (Part No. 23395) close to the product where they can be seen by the system operator (also refer to Fig. 13 on page 28).



CAUTION! RISK OF DAMAGE!

Never operate the belt cleaner for longer than 15 minutes on the running, unloaded conveyor belt. A risk of damage due to overheating exists for the belt cleaner and/or the conveyor belt. *Only operate the belt cleaner on a running and fully loaded conveyor belt.*

2. Remove all tools and fire protection covers from the installation site and the conveyor belt.
3. Perform a 1-hour test run of the conveyor system.
4. Shut off the conveyor system after the test run, shut off the power supply and secure it against unauthorised reactivation.
5. Check whether all of the fastening parts are securely tightened. Tighten any loose connections.

6. Inspect the belt cleaner for the following conditions:
 - **Wear:** a small amount of break-in wear is normal. As soon as the cleaning elements have adapted to the contour of the conveyor belt, this phenomenon ceases.
 - Bulk material accumulation: No bulk material may accumulate between the cleaning elements and the return side.
7. Note the corresponding information in Section 7 “Troubleshooting” in cases of excess wear, bulk material accumulation or other problems.

5.4

Placement of warning labels and warning tags

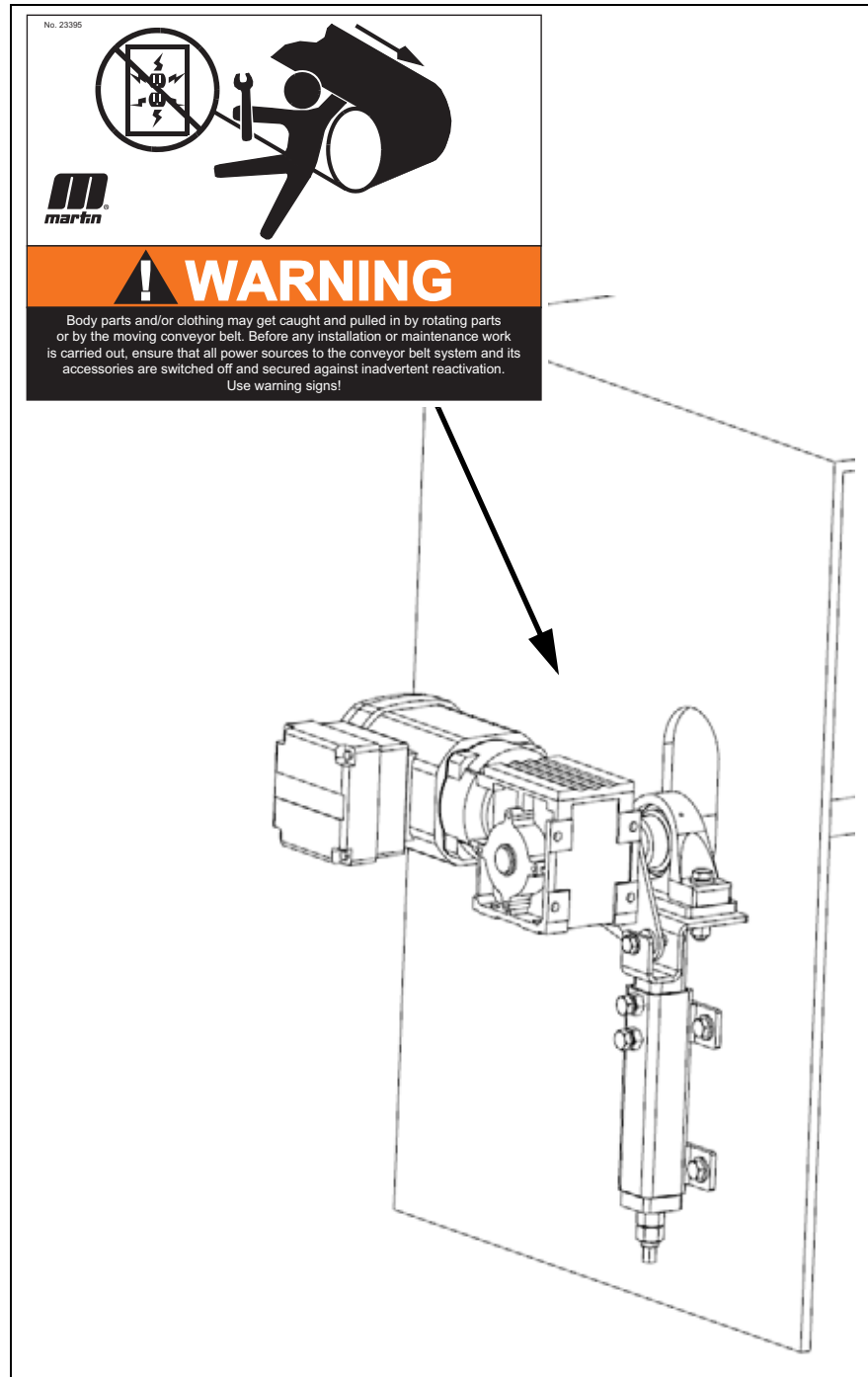

Fig. 12:

6 Maintenance

6.1 Safety information



NOTE

Maintenance inspections must be performed at least once a week. Shorter maintenance intervals may be required depending on the operating conditions.



NOTE

Read this section completely before starting any kind of work.



WARNING! RISK OF INJURY!

Body parts and/or clothing may get caught and pulled in by rotating parts or by the moving conveyor belt.
Shut off the power supply to the conveyor system and its accessories and secure it against unauthorised reactivation before performing any maintenance work.
Use warning signs!

6.2 Weekly maintenance

1. Shut off the power supplies of the conveyor belt and any additional equipment and secure them against unauthorised reactivation.
2. Remove all material deposits from the cleaning elements and the mainframe.
3. Inspect whether all of the fastening parts are securely tightened. Tighten any loose connections.
4. Check the cleaner tension and re-tighten if necessary.
5. Check the cleaning elements for wear, damage and missing parts.



NOTE

Check wear and adjustments once a month, adjust if necessary. The cleaning elements must always make sufficient contact with the conveyor belt.



NOTE

Take the corresponding parts out of service if any indications of functional disturbances are noticed. Contact Martin Engineering or one of its representatives for support. Do NOT start up the conveyor system until the cause of the problems has been recognised and eliminated.



CAUTION! RISK OF DAMAGE!

Cleaning elements may not abrade under the height of the fixing screws on the shaft or must still have at least an outer diameter of 90 mm, otherwise this can lead to serious material damage.
Inspect cleaning elements regularly and replace in time!

6. If the cleaning elements have a diameter of less than 90 mm, these must be replaced in accordance with the instructions in Section 6.3.
7. Clean all the warning labels. Replace illegible warning labels immediately. Warning labels can be purchased from Martin Engineering or a contracted dealer.



CAUTION! FLYING OBJECTS!

Forgotten tools or installation parts can fall off of the running conveyor belt and cause minor injuries and property damage.
Always remove any tools from the installation site and conveyor belt upon completion of the installation work before switching on the power supply.



NOTE

The angled gearbox motor must be checked at least once a month for oil level, oil change, leaks, etc. Observe instructions in the manufacturer documentation on maintenance intervals!



NOTE

The bearing of the angled gearbox motor must be checked at least once a week for lubrication, damage, running performance, etc. Observe the information in the manufacturer's documentation supplied with the device!



NOTE

The bearings are lubricated for continuous operation, and relubrication is not absolutely necessary. The bearings may need to be relubricated under extreme conditions such as high temperatures, temperature fluctuations and high dust exposure.

For example, the grease Arcanol MULTI2 (lithium soap on mineral oil basis, viscosity at 40 °C \geq ISO VG 68 mm²/s) can be used for relubrication. This grease is suitable for temperatures from -30 °C to +120 °C, or 75 °C continuous temperature. Refer to the corresponding documentation of the pillow blocks for additional information.

Relubrication intervals and quantities need to be defined as needed. The manufacturer specifies 60,000 h for speeds under 200 rpm.

8. Remove all tools from the working area.
9. Switch on the conveyor system.



WARNING! RISK OF INJURY!

Body parts and/or clothing may get caught and pulled in by rotating parts or by the moving conveyor belt.

Do not touch or reach into the conveyor system or its accessories during operation.

10. Observe the brush cleaner and check its cleaning performance.

6.3

Replacement of the cleaning elements



WARNING! RISK OF INJURY!

Body parts and/or clothing may get caught and pulled in by rotating parts or by the moving conveyor belt.

Before any installation or maintenance work is carried out, ensure that all power sources to the conveyor belt system and its accessories are switched off and secured against unauthorised reactivation. Use warning signs!

6.3.1

Lowering of secondary cleaner

The secondary cleaner must be lowered before carrying out maintenance work or before de-installation.

The following steps are necessary for this:

1. Loosen the clamping screws (1, Fig. 14).
2. Loosen the lock nuts (2, Fig. 14).
3. Loosen the securing nuts (4, Fig. 14).

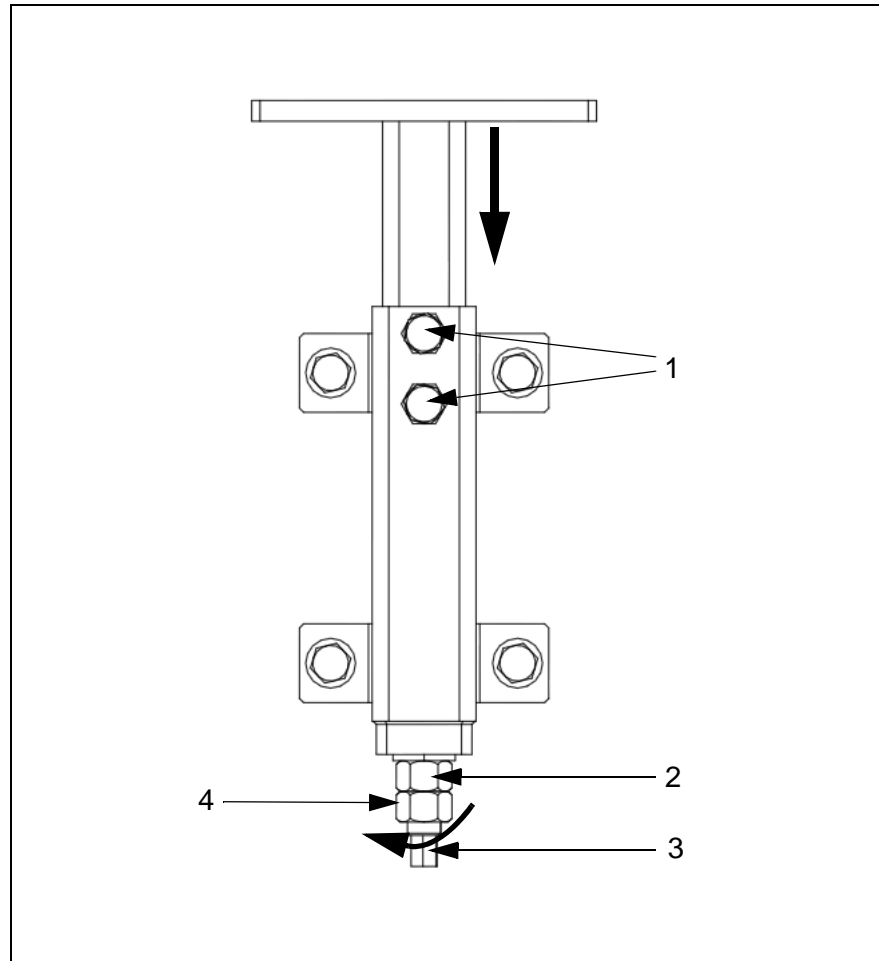

Fig. 13:

Pos.	Description
1	Clamping screw
2	Securing nut
3	Adjusting screw
4	Lock nut

Tab. 6: Description of nuts and screws

4. Turn adjusting screw (3, Fig. 14) in the clockwise direction to lower the brush cleaner.

**NOTE**

Lower the MARTIN® brush cleaner so that the cleaning elements no longer touch the conveyor belt.

5. Repeat working steps on the opposite side.

6.3.2

Replace cleaning elements



CAUTION! RISK OF INJURY!

The angled gearbox motor can be turned out of the way during the dismantling.

Secure angled gearbox motor before dismantling.



NOTE

The old and new cleaning elements should always be the same (material and pattern type).

1. Disconnect the power cable from the angled gearbox motor (if necessary).
2. Pull the angled gearbox motor (1, Fig. 15) off the shaft of the secondary cleaner and lay it on a level, firm surface or secure appropriately.



NOTE

Make sure that the electrical power cable does not remain hanging and is not subjected to any mechanical strain. Secure appropriately if the power cable has not been removed.

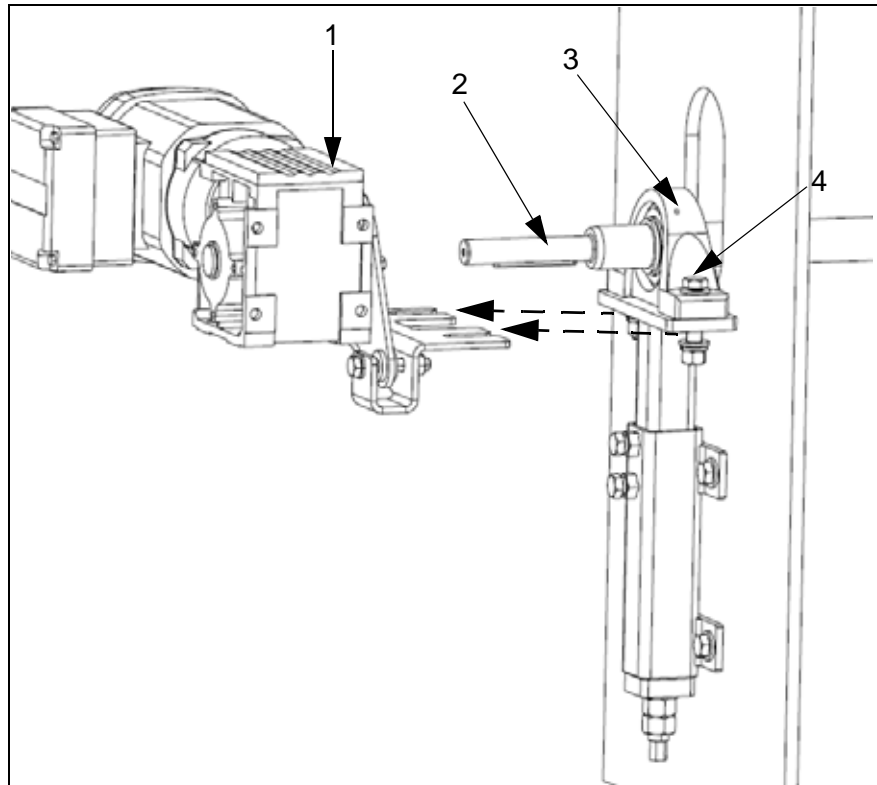

Fig. 14:

3. Loosen the bolts from both sides of the pillow block (3, Fig. 15) and pull it and the main shaft with the pillow blocks from the chute.

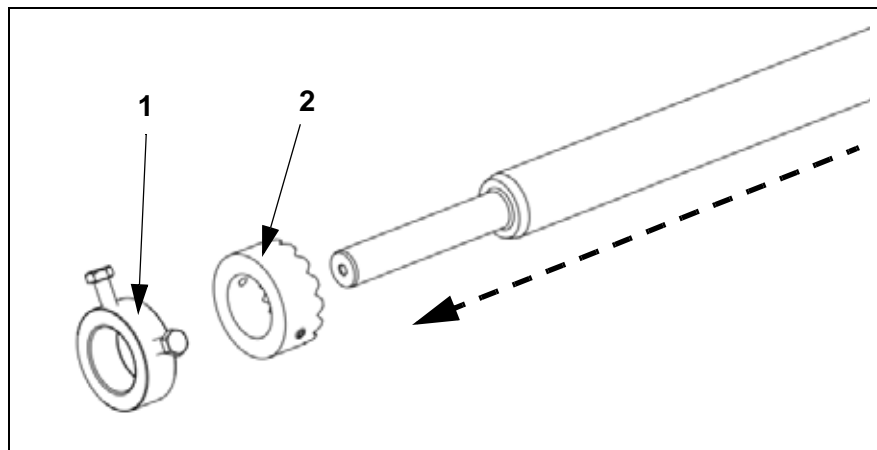

Fig. 15: De-installation of the cleaning elements

4. Loosen screws in the locking ring (1, Fig. 16) and the adjustment ring for the zigzag system (2, Fig. 16) at one side and pull off from the main shaft.

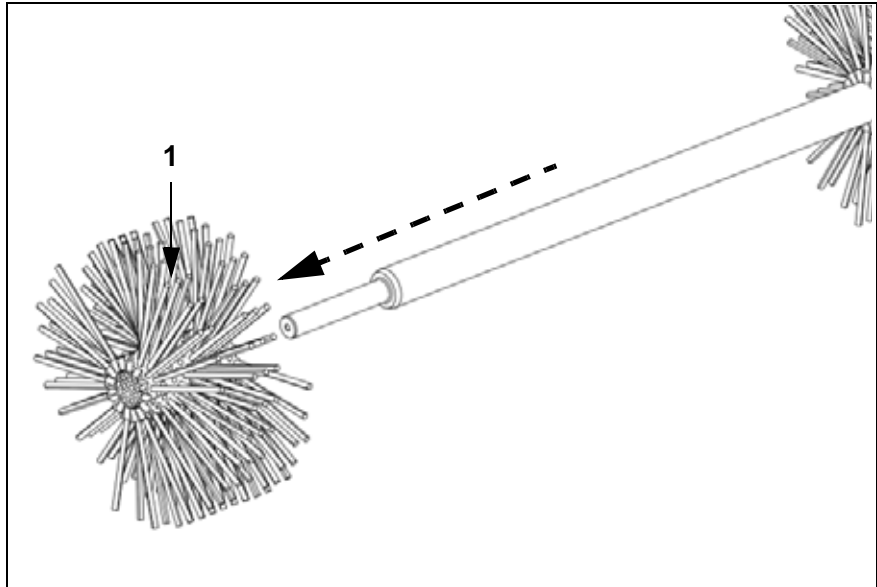

Fig. 16:

5. Worn cleaning elements (1, Fig. 17) can now be replaced.
6. Install the secondary cleaner as in Section “Installing the cleaner”.

7 Troubleshooting

7.1 Safety information



NOTE

The product is exposed to many different types of bulk materials and is often used under extreme operating and environmental conditions. Malfunctions other than those listed below can therefore occur.

In this case, either Martin Engineering or one of its representatives can assist with the positioning or with special solutions. Do not start up the conveyor system again until the fault has been recognised and cleared.

7.2 Troubleshooting

Check the following items if excessively high wear on the cleaning elements and/or unsatisfactory cleaning performance is noticed following installation:

Symptom	Cause	Remedy
High wear on the cleaning elements, noise or vibration.	The cleaner is too heavily loaded.	Reduce the tension in the tensioner (see Section 5.2.8).
Inadequate cleaning effect.	The cleaner loading is too lightly set.	Increase the pre-tension of the tensioner. The bristles of the cleaning elements must be bent by approx. 3-4 mm at the conveyor belt.
	Too high operating temperature.	The MARTIN® brush cleaner can be used in the temperature range 0° C to +100° C.
	Cleaning elements do not rotate with the rest.	Cleaning elements are not fixed to the shaft; check fixing elements. (zigzag system)
	Cleaning performance inadequate due to high dirt accumulation.	Install a pre-cleaner as an extra.
	Cleaning elements are worn.	Renew cleaning elements, as described in Section 6.3.2.

Tab. 7: Troubleshooting

Symptom	Cause	Remedy
Unusual noises of cleaning results.	Maintenance intervals have not been observed.	The angled gearbox motor must be maintained at intervals of 10,000 working hours in accordance with the documentation supplied.
	Wrong direction of rotation of the angled gearbox motor.	The angled gearbox motor must rotate in the direction opposite to that of the conveyor belt.
	Impacts, conveyor belt vibration. Motor imbalance, heavy dirt on the cleaning elements.	Brush cleaner installed too far from head pulley or return idler removed. Align shaft to gearbox. Wrong cleaning elements used.
Excessive accumulation of material	The cleaner loading is too lightly set.	Reduce the set distance of the cleaning elements to the conveyor belt.
	Cleaning elements have increased material residues.	Install cleaning elements of a different trim type.
Uneven wear of the cleaning elements	Cleaning elements are not evenly arranged under the conveyor belt.	Align the brush cleaner horizontally to the conveyor belt.
	Cleaning elements are not centred on the belt loading. Cleaning width too small.	Check alignment, installation. Adjust cleaning width.
Motor gets hot, does not rotate.	Shaft touches the frame, setting too high, brush cleaner badly aligned. Fibres on the brush or in the bearing, bristles filled with bulk material.	Check and correct alignment, installation; wrong brush type.

Tab. 7: Troubleshooting

8 Storage, de-installation, disposal

8.1 Packing and transportation

The products described here are packed and shipped by Martin Engineering.

The products may be transported solely in the Martin Engineering packaging.

The logistics company in charge of the shipment shall be responsible for any damage and/or loss.

8.2 Storage

To ensure optimal function of the product, Martin Engineering recommends storing its components in a dry place at room temperature where they are protected against direct sunlight.

The best storage conditions are at temperatures ranging from +0 °C to +30°C and 60% relative humidity.

Martin Engineering guarantees that the stored products will remain fully functional for at least 2 years under the storage conditions specified here.

8.3 De-installation

The de-installation is carried out in the reverse order to that of the installation (see Section 5.2.2, page 15).

8.4 Disposal

Assemblies and/or single parts of the Martin Engineering products must be professionally disposed of after usage as follows.

- Complete assemblies must be dismantled, sorted by material type, and separately disposed of.

Comply with all nationally and internationally applicable disposal regulations when disposing of the product.

9 Part numbers

This section lists the product designations with their associated part numbers for the MARTIN® Brush Cleaner system and its accessories.

Please always indicate the part numbers in every order.

9.1 Explanation of part numbers

Martin® Brush Cleaner

41580-aabccddeeffg-hh	
a	Belt width in inches
b	Brush pattern version
	F: Full
	S: Spiral-shaped
	L: Straight
c	Bristle material
	PB: Polyester (PBT)
	BR: Brass
d	Cleaning width in inches
e	Main shaft material
	MS: Mild steel (1.0037)
	A2: Stainless steel (1.4031)
f	Voltage (V)
	11: 110
	23: 230
	40: 400
	46: 460
g	Frequency in Hertz
	5: 50
	6: 60
h	Further options
	X: Is simply incremented

9.2 MARTIN® Inspection doors

With standard rubber door, up to 68 °C:

- 229 x 305 mm: Part no. CYAR-0912M.
- 305 x 356 mm: Part no. CYAR-1214M.
- 305 x 457 mm: Part no. CYAR-1218M.
- 457 x 610 mm: Part no. CYAR-1824M.
- 610 x 610 mm: Part no. CYAR-2424M.

9.3**Installation manuals**

- **Martin® Inspection Door:** Publication no. M3127.

9.4**Warning labels / Warning tags**

- **Conveyor Products Warning Label:**
Part no. 23395

9.5**Accessories and options****9.5.1****Inspection doors**

When installing the MARTIN® Brush Cleaner on an encapsulated transfer system, a MARTIN® Inspection Door is recommended for improved accessibility during inspection and maintenance. This can be purchased from Martin Engineering or a contracted dealer.

9.5.2**Cleaning elements**

The cleaning elements for the MARTIN® Brush Cleaner are available in various material and trim versions. The appropriate type of material and trim is selected depending on the working conditions (bulk material, temperature etc.). Please take further specifications from the appropriate data sheet of the MARTIN® Brush Cleaner L3863.

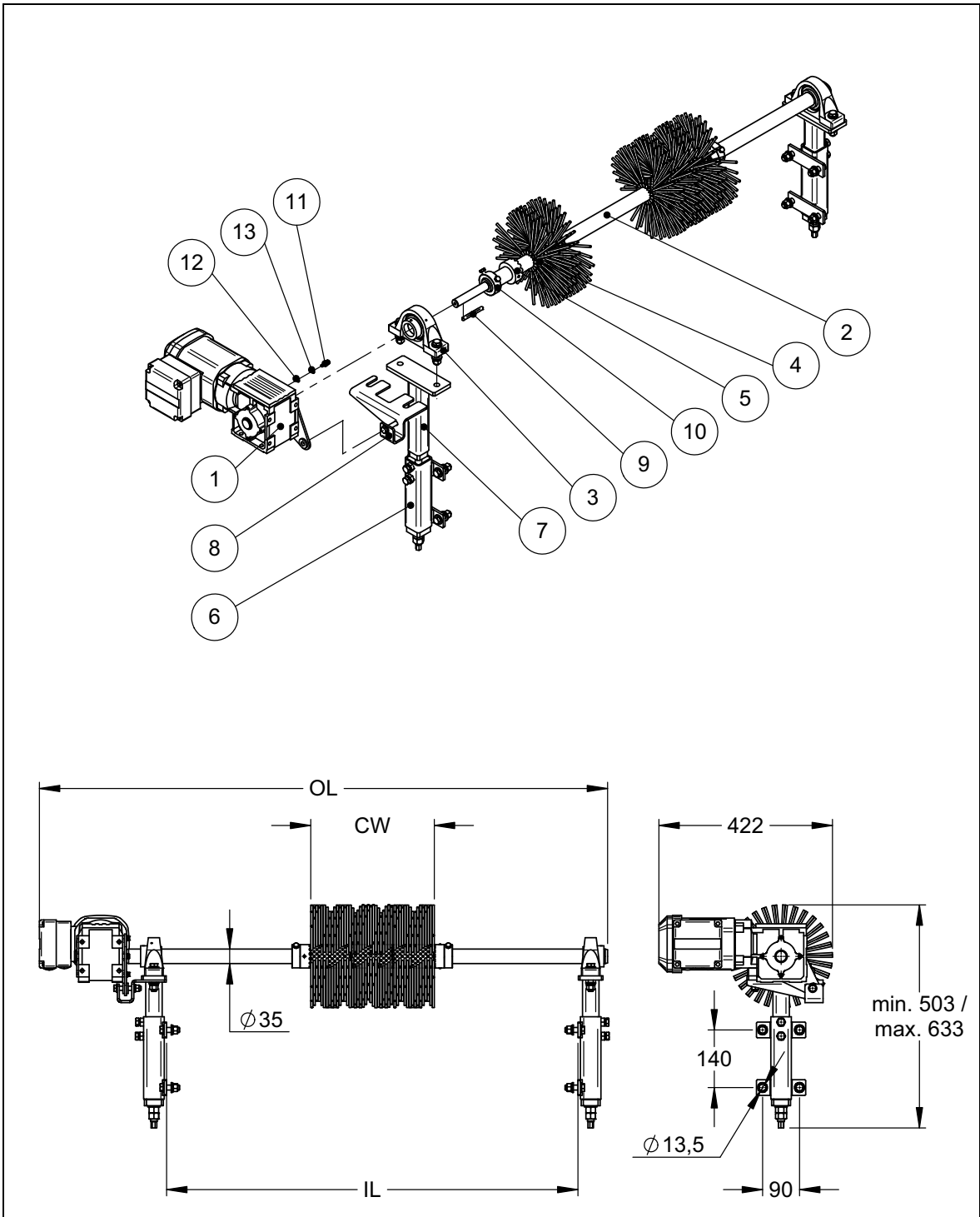

Fig. 17:

Part numbers

Item / Pos.	Qty / Anz.	Description / Beschreibung	P/N / Teile-Nr.
1	1	Spiroplan-Angle-Gearmotor / Spiroplan-Winkelgetriebemotor	41582-XXX
2	1	Mainframe / Hauptachse	41581-18
3	2	Bearing pillow block / Stehlager-Gehäuseeinheit	41584-035-A
4	s.C. / s.T.	Spiral brush edging zick-zack system / Spiralbürste Besatz Zick-Zack System	s.C. / s.T.
5	2	Fixing collar for Zick-Zack System / Stellring Zick-Zack System	41587-035
6	2	Tensioner for Brush Cleaner / Spannvorrichtung für Bürstenreiniger	41589-A
7	2	Bearing mounting console / Lager Montagekonsole	41591
8	1	Support plate for engine torque arm / Aufnahmeblech für Motor-Drehmomentstütze	41592-A
9	1	Feather keys DIN 6885-A, 6 x 6 x 70 mm / Passfeder	41588-A-06-06-70
10	2	Locking ring / Sicherungsring	41593-035-A
11	4	HHC screw M6 x 20 - DIN 933, (1.0032) galv. / Sechskantschraube	41081-06020BZP88
12	4	Washer flat M6 - DIN 125 A, (1.0032) galv. / Unterlegscheibe	41088-06AZP
13	4	Washer spring M6 - DIN 127, (1.0032) galv. / Federring	41090-06AZP



Part number / Teilenummer	DIM				PN Item / Teilenr. Pos.	Qty. Item / Anz. / Pos.
	CW		IL	OL	1	4
	[inch]	[mm]				
41580-18XXX12XXXXXX-00	12	300	1000	1382	41581-18XXX	3
41580-24XXX20XXXXXX-00	20	500	1150	1532	41581-24XXX	5
41580-30XXX24XXXXXX-00	24	600	1300	1682	41581-30XXX	6
41580-36XXX28XXXXXX-00	28	700	1450	1832	41581-36XXX	7
41580-42XXX36XXXXXX-00	36	900	1600	1982	41581-42XXX	9
41580-48XXX40XXXXXX-00	40	1000	1750	2132	41581-48XXX	10
41580-48XXX43XXXXXX-00	43	1100	1750	2132	41581-48XXX	11
41580-54XXX47XXXXXX-00	47	1200	1900	2282	41581-54XXX	12
41580-60XXX51XXXXXX-00	51	1300	2050	2432	41581-60XXX	13
41580-66XXX59XXXXXX-00	59	1500	2200	2582	41581-66XXX	15
41580-72XXX63XXXXXX-00	63	1600	2350	2732	41581-72XXX	16
41580-78XXX71XXXXXX-00	71	1800	2400	2882	41581-78XXX	18

Part numbers

Part number / Teilenummer	PN Item / Teilenr. Pos.
	1
41580-XXXXXXXXMSXX-00	41581-XXMS
41580-XXXXXXXXA2XX-00	41581-XXA2

Part number / Teilenummer	PN Item / Teilenr. Pos.	Part number / Teilenummer	PN Item / Teilenr. Pos.
	2		2
41580-XXXXXXXXXX11X-00	41582-11X	41580-XXXXXXXXXXXXX5-00	41582-XXX5
41580-XXXXXXXXXX23X-00	41582-23X	41580-XXXXXXXXXXXXX6-00	41582-XXX6
41580-XXXXXXXXXX40X-00	41582-40X		
41580-XXXXXXXXXX46X-00	41582-46X		

Part number / Teilenummer	PN Item / Teilenr. Pos.
	4
41580-XXXPBXXXXXXXX-00	41586-10PBX
41580-XXXBRXXXXXXXX-00	41586-10BRX

Part number / Teilenummer	PN Item / Teilenr. Pos.	Type of brush pattern / Ausführung des Bürstenbesatzes	
	4		
41580-XXFXXXXXXXXXX-00	41586-10XF	Full seat / Voll	
41580-XXSXXXXXXXXXX-00	41586-10XS	Spiral / Spiralförmig	
41580-XXLXXXXXXXXXX-00	41586-10XL	Linear / Linear	

9.6.1**Technical Specification Angular Gear Motor**

- Operating voltage 110V-460V at 50/60 Hz 4-pole (special voltages possible on request).
- Output: 0.55 kW
- Current consumption: 1.55 A at 400V/50Hz
- Ingress protection: IP55
- Protection class: ISO-F
- Speed: 135 rpm 50 Hz
- Peripheral speed: 0.4 m/s @ 50 Hz
- Operating temperatures: -20°C to +60°C



**Declaration of incorporation in accordance with
Machinery Directive (2006/42/EG)
Annex II B for the installation of an incomplete machine**

We, Martin Engineering,

In der Rehbach 14

Tel.: +49 6123-97820

D-65396 Walluf

Fax: +49 6123-75533

herewith declare that the product named in the following

Product designation:

Conveyor belt cleaner

of make / type:

MARTIN[®] Brush Cleaner

with serial number:

not required

meets the following requirements:

Machinery Directive 2006/42/EC

DIN EN 618 - Equipment and systems for bulk materials

DIN/EN 1083-1; -2 Power-driven brushes

The following harmonised standards were particularly applied:

DIN EN ISO 12100 Safety of Machinery

Notified authority:

not required

The installation instructions belonging to the product and the technical documentation are enclosed with the product in their original version.

The commissioning of this product is prohibited until it has been determined that the system in which it is to be installed meets the requirements of versions 98/37/EC and 2006/42/EC of the EC Directive.

Date: 21/01/2010

Manufacturer's signature: Managing director, Michael Hengl



PROBLEM SOLVED™

USA (Headquarters)

Martin Engineering

One Martin Place, 61345 Neponset (Illinois), USA
Tel. +1 (800) 544-2947; Fax +1 (800) 814-1553
info@martin-eng.com; www.martin-eng.com

European subsidiaries

Great Britain

Martin Engineering Ltd.

8, Experian Way, NG2 Business Park,
Nottingham NG2 1EP, Nottinghamshire, Great Britain
Tel. +44 115 946 4746; Fax +44 115 946 5550
info@martin-eng.co.uk; www.martin-eng.co.uk

France

Martin Engineering SARL

50 Avenue d'Alsace, 68025 Colmar Cedex, France
Tel. +33 389 20 63204; Fax +33 389 20 4379
info@martin-eng.fr; www.martin-eng.fr

Russia

OOO Martin Engineering

Ul. Bolshaya Dmitrovka, 23/1
125009 Moscow, Russia
Tel +7 495 181 33 43; Fax +7 499 720 62 12
info@martin-eng.ru; www.martin-eng.ru

Germany (Main European branch)

Martin Engineering GmbH

In der Rehbach 14, 65396 Walluf, Germany
Tel. +49 6123 97820; Fax +49 6123 75533
info@martin-eng.de; www.martin-eng.de

Turkey

Martin Engineering Makina Sanayi ve Ticaret Ltd.Sti

Yukari Dudullu Imes Sanayi Sitesi, B Blok 205 Sokak No.6
34775 Ümraniye Istanbul, Turkey
Tel. +90 216 4993 491; Fax +90 216 4993 490
info@martin-eng.com.tr; www.martin-eng.com.tr

Italy

Martin Engineering Italy Srl

Via Buonarroti, 43/A, 20064 Gorgonzola (MI), Italy
Tel. +39 295 3838 51; Fax +39 295 3838 15
info@martin-eng.it; www.martin-eng.it

Subject to technical modifications
Quality management system certified by DNV - ISO 9001

