

# Martin® Inspection Doors



Available in mild steel or stainless steel, Martin® Inspection Doors provide quick and easy access to belt cleaners and other components inside chutes and enclosures for inspection or service.

The inspection doors can be used in in temperatures from -30°C up to +80°C. Various sizes are available depending on the needs.

### BENEFITS

- **Safe:**  
Improves safety when conducting maintenance, inspections and cleaning of the conveyor components.
- **Versatile:**  
Various sizes available. Available in mild and stainless steel option. Steel door withstands typical positive and negative pressure applications.
- **Compliant with safety requirements:**  
Mesh size of the barrier guard and captive screws make the doors fully compliant with European safety standards.
- **Dust-Tight Seal:**  
Latch closes the door tightly and rubber seal prevents material escape.
- **Easy to install:**  
Door is bolted to enclosure wall.
- **Compact:**  
“Low-Profile” design makes it easy to fit the door into tight spaces.

### NOMENCLATURE

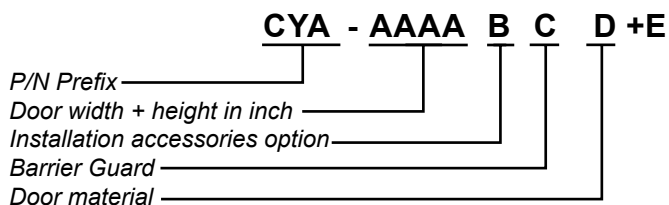

**A: Door dimensions**  
 Approximate door size  
 in inches (width x height)

**E: Barrier Guard**  
**G:** with Barrier Guard

**B: Installation accessories option**  
**M:** with mounting kit

**D: Door material**  
**P:** Mild Steel Painted  
**A2:** Stainless Steel (1.4301)

# TECHNICAL DATA SHEET

## MARTIN® INSPECTION DOOR DIMENSIONS

Assy P/N	"A" (mm)	"B" (mm)	"C" (mm)	"D" (mm)
CYA-0912MG-X+E	286	365	210	289
CYA-1212MG-X+E	360	365	284	289
CYA-1214MG-X+E	360	410	284	337
CYA-1218MG-X+E	360	515	284	438

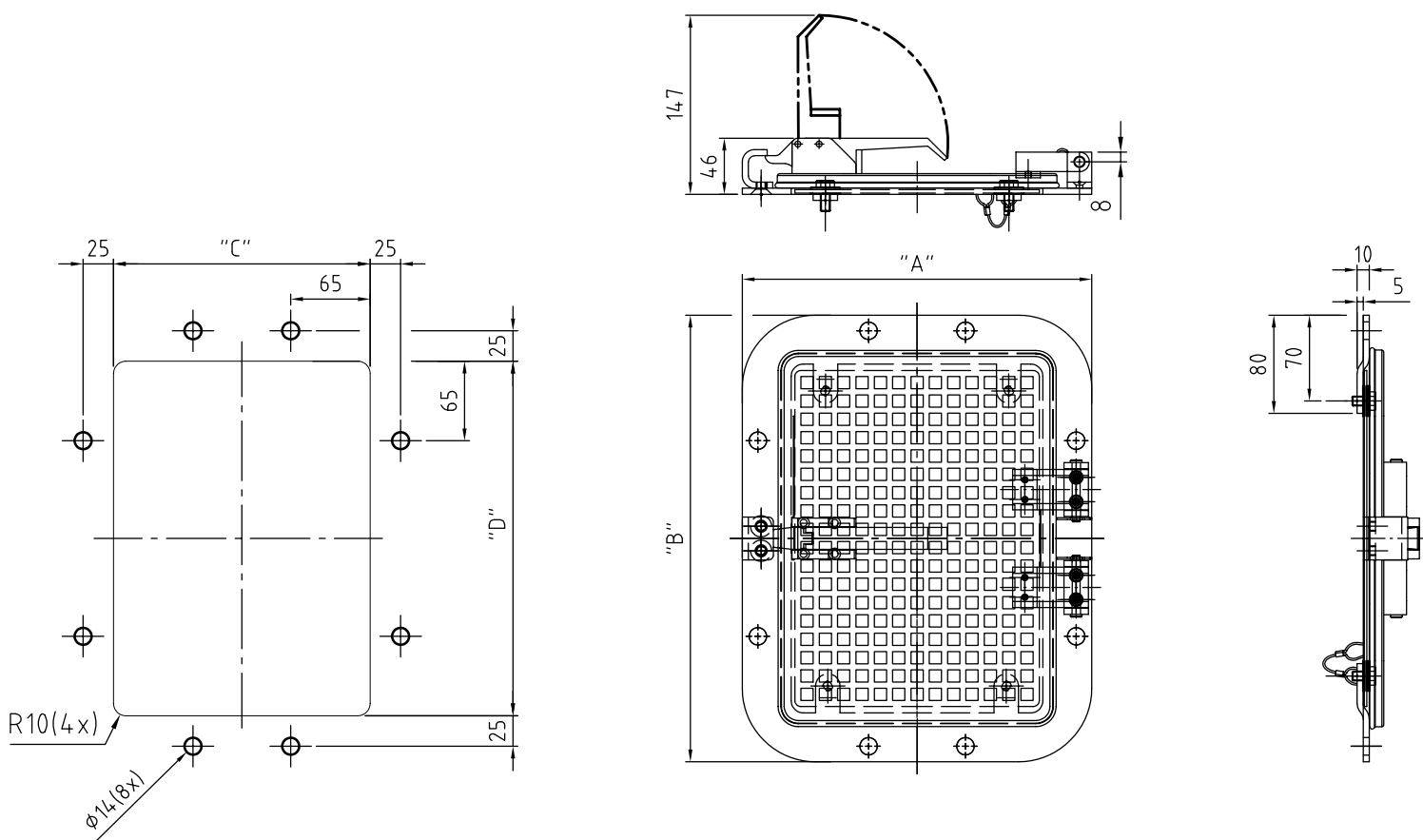

## MARTIN® INSPECTION DOOR DIMENSIONS (2)

Assy P/N	"A" (mm)	"B" (mm)	"C" (mm)	"D" (mm)
CYA-1818MG-X+E	515	515	438	438
CYA-1824MG-X+E	515	665	438	589
CYA-2424MG-X+E	665	665	583	583
CYA-3030MG-X+E	850	550	768	768

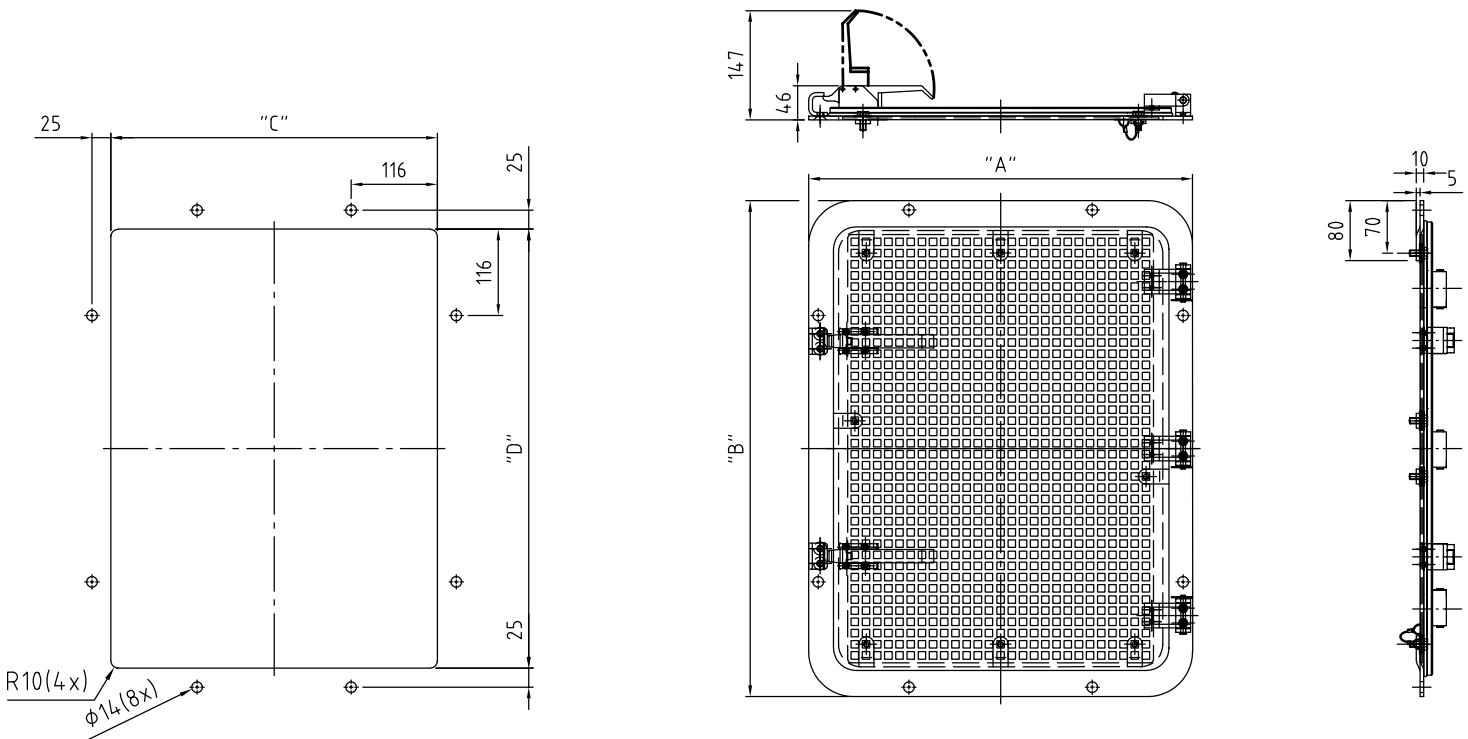

**Martin Engineering Germany**  
 In der Rehbach 14  
 65396 Walluf, Germany  
 Ph.: 0049 (0)6123 9782 0  
 info@martin-eng.eu | www.martin-eng.de

**Martin Engineering Ltd**  
 8, Experian Way, NG2 Business Park  
 Nottingham NG2 1EP Nottinghamshire, UK  
 Ph.: 0044 (0)115 946 4746  
 info@martin-eng.co.uk | www.martin-eng.co.uk



Subject to change without prior notice. Quality management system certified according to DNV - ISO 9001