

martin®

Martin®
Slider Cradle

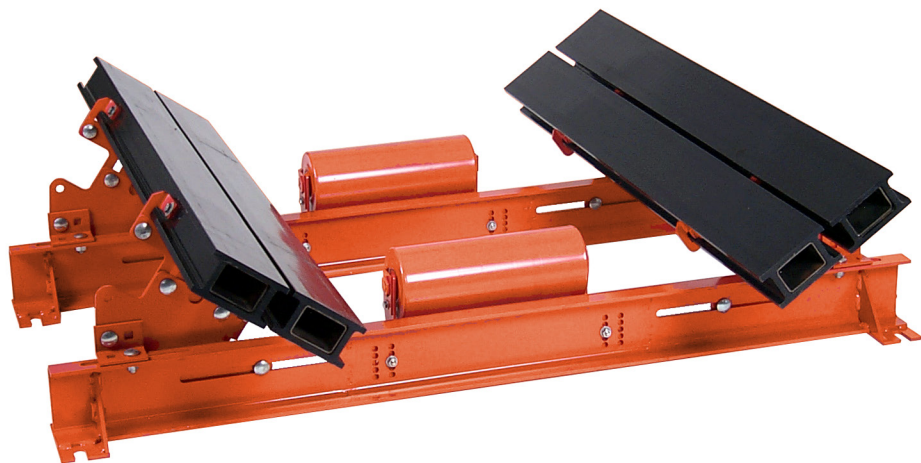

Operator's Manual
M3596

Important

MARTIN ENGINEERING HEREBY DISCLAIMS ANY LIABILITY FOR: DAMAGE DUE TO CONTAMINATION OF THE MATERIAL; USER'S FAILURE TO INSPECT, MAINTAIN AND TAKE REASONABLE CARE OF THE EQUIPMENT; INJURIES OR DAMAGE RESULTING FROM USE OR APPLICATION OF THIS PRODUCT CONTRARY TO INSTRUCTIONS AND SPECIFICATIONS CONTAINED HEREIN. MARTIN ENGINEERING'S LIABILITY SHALL BE LIMITED TO REPAIR OR REPLACEMENT OF EQUIPMENT SHOWN TO BE DEFECTIVE.

Observe all safety rules given herein along with owner and Government standards and regulations. Know and understand lockout/tagout procedures as defined by American National Standards Institute (ANSI) z244.1-1982, *American National Standard for Personnel Protection - Lockout/Tagout of Energy Sources - Minimum Safety Requirements* and Occupational Safety and Health Administration (OSHA) Federal Register, Part IV, 29 CFR Part 1910, *Control of Hazardous Energy Source (Lockout/Tagout); Final Rule*.

The following symbols may be used in this manual:



Danger: Immediate hazards that will result in severe personal injury or death.



Warning: Hazards or unsafe practices that could result in personal injury.



Caution: Hazards or unsafe practices that could result in product or property damages.



Important: Instructions that must be followed to ensure proper installation/operation of equipment.



Note: General statements to assist the reader.

Table of Contents

Section	Page
List of Figures	ii
List of Tables	ii
Introduction	1
General	1
References	1
Safety	2
Materials required	2
Before Installing Slider Cradle	3
Installing Slider Cradle	4
Installing Single-Bar Cradle	4
Installing Double-Bar Cradle	7
After Installing Slider Cradle	12
Weekly Maintenance	13
Adjusting for Wear	13
Turning Bars Over	13
Troubleshooting/Installation Checklist	15
Part Numbers	17
Appendix	A-1

List of Figures

Figure	Title	Page
1	Locating Slider Cradle Between Idlers (Single-Bar Cradle shown)	5
2	Location of Slider Cradle to Idlers	6
3	Setting Trough Angle	6
4	Installing Single-Bar Cradle	7
5	Installing Double-Bar Cradle	9
6	Bracket Settings and Dimensions	11
7	Adjusting or Replacing Slider Bars	14
8a	Martin [®] Slider Cradle Assembly (Single-Bar) P/N 36700-18X	18
8b	Martin [®] Slider Cradle Assembly (Single-Bar) P/N 36700-18X Parts List	19
9a	Martin [®] Slider Cradle Assembly (Single-Bar) P/N 36700-XXX	20
9b	Martin [®] Slider Cradle Assembly (Single-Bar) P/N 36700-XXX Parts List	21
10a	Martin [®] Slider Cradle Assembly (Double-Bar) P/N 36700-XXX	22
10b	Martin [®] Slider Cradle Assembly (Double-Bar) P/N 36700-XXX Parts List	23
11	Conveyor Products Warning Label, P/N 23395	25

List of Tables

Table	Title	Page
I	Martin [®] Slider Bar Specifications	1
II	Center Roll Height Based on CEMA Standards (Reference Only)	10
III	Center Roll Bracket Settings (Refer to Figure 6)	10
IV	Idler Support Bracket, Mounting Tabs Direction	11
V	Single-Bar Part Numbers and Weights	21
VI	Double-Bar Part Numbers and Weights	24

Introduction

General

The Martin® Slider Cradle holds conveyor belts in a stable, sag-free position to allow effective sealing. By minimizing belt vibration and sag, the Martin® Slider Cradle reduces escaping material and risk of damage to the belt and conveyor accessories. Martin® Slider Bars provide a low-friction, self-lubricating surface for conveyor belts to skim over without heat buildup or undue wear on the belt surface or bars (see specifications in Table I). The Martin® Slider Cradle is not intended to absorb impact.

Single-Bar Martin® Slider Cradles are suitable for light- to moderate-duty belts from 18- to 42-in. (400- to 1200-mm) wide with belt speeds less than 500 fpm (2.5 m/s).

Double-bar Martin® Slider Cradles are recommended for moderate- to severe-duty belts from 48- to 96-in. (1200- to 2400-mm) wide with belt speeds greater than 500 fpm (2.5 m/s).

The Martin® Slider Cradle conforms to CEMA Standard No. 502-1980 Bulk Material Conveyor Troughing and Return Specifications (CEMA Class D6).

Table I. Martin® Slider Bar Specifications

Bar construction	UHMW polyethylene
Bar dimensions	2.9-in. (72-mm) high 5.0-in. (127-mm) wide 48-in. (1220-mm) long
Coefficient of friction	0.5
Specific gravity	0.94
Tensile strength	6800 lb at 73°F (23°C)
Hardness	62 (Shore D)
Service temperature	-20 to 140°F (-29 to 60°C)

References

The following documents are referenced in this manual:

- American National Standards Institute (ANSI) z244.1-1982, *American National Standard for Personnel Protection - Lockout/Tagout of Energy Sources - Minimum Safety Requirements*, American National Standards Institute, Inc., 1430 Broadway, New York, NY 10018.
- Federal Register, Volume 54, Number 169, Part IV, 29 CFR Part 1910, *Control of Hazardous Energy Source (Lockout/Tagout); Final Rule*, Department of Labor, Occupational Safety and Health Administration (OSHA), 32nd Floor, Room 3244, 230 South Dearborn Street, Chicago, IL 60604.

Safety

All safety rules defined in the above documents, and all owner/employer safety rules must be strictly followed when working on the Martin® Slider Cradle.

Materials required

In addition to standard hand tools, a 5-ft (1.5-m) angle is needed to install this equipment.

Before Installing Slider Cradle

IMPORTANT

The delivery service is responsible for damage occurring in transit. Martin Engineering CANNOT enter claims for damages. Contact your transportation agent for more information.

1. Inspect shipping container for damage. Report damage to delivery service immediately and fill out delivery service's claim form. Keep any damaged goods subject to examination.
2. Remove Martin® Slider Cradle from shipping container. Equipment in container should include the following:
 - Martin® Slider Cradle Single-Bar or Double-Bar Cradle Assembly.
 - Two Conveyor Products Warning Labels, P/N 23395.
3. If anything is missing, contact Martin Engineering or representative.



⚠ DANGER

Before installing, servicing, or adjusting conveyor equipment, turn off and lockout / tagout / blockout / testout all energy sources to the conveyor and conveyor accessories according to ANSI standards. Failure to do so could result in serious injury or death.

1. Turn off and lockout / tagout / blockout / testout energy source according to ANSI standards (see "References").

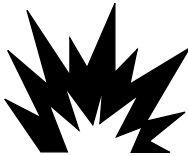

⚠ WARNING

If equipment will be installed in an enclosed area, gas level or dust content must be tested before using a cutting torch or welding. Using a cutting torch or welding in an area with gas or dust may cause an explosion.

4. If using a cutting torch or welding, test atmosphere for gas level or dust content. Cover conveyor belt with fire-retardant cover.
5. If not already present, install an impact idler 1 in. (25 mm) ahead of and 1 in. (25 mm) behind Single-Bar Cradle's location. Make sure idlers are straight and centered under conveyor belt.
6. Remove any unnecessary idlers.

Installing Slider Cradle

IMPORTANT

Read entire section before beginning work.

NOTE

Refer to Appendix for mounting dimensions of Martin® Slider Cradles used with 5 and 6 inch idlers.

To install the Martin® Slider Cradle, follow the procedures corresponding to the following steps:

1. Locate slider cradle between idlers.
2. Install sub-assemblies as applicable.
3. Adjust roller assemblies.

IMPORTANT

The Martin® Slider Cradle requires a minimum of 50 in. (1270 mm) between idler faces.

1. Find center point between idlers and mark point on both stringers.
2. Measure 12 in. (305 mm) from center point in both directions and mark points on both stringers. These will be reference points for steps 3 and 4.

Installing Single-Bar Cradle



NOTE

If center support roll is used, refer to Table 2 and Figure 6 for mounting details. Mount brackets should be installed prior to step 3 but can be installed during a later step.

3. Place one sub-assembly across the conveyor stringers, placing feet of the support on each conveyor stringer on the reference mark from step 2.
4. Place the second sub-assembly across the conveyor stringers as in step 3. Space approximately 24 in. (610 mm) apart.



5. Install both slider bars, one on each side of the conveyor, making sure holes line up, and fasten down with bolts provided.

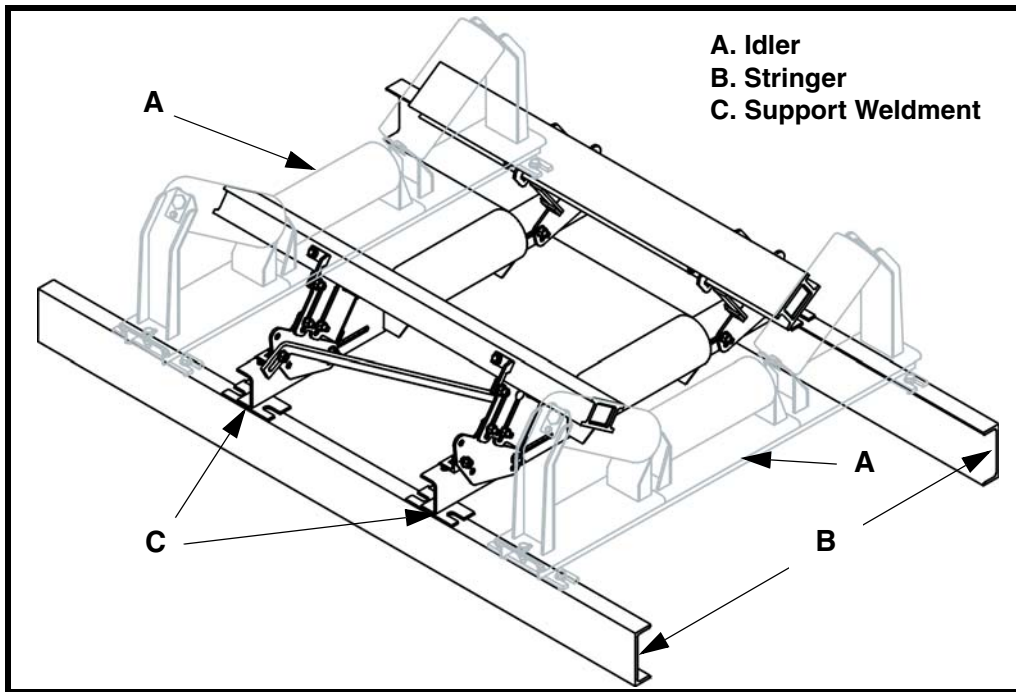

Figure 1. Locating Slider Cradle Between Idlers (Single-Bar Cradle shown)

6. Center slider cradle between remaining idlers (refer to Figure 1). Idlers should be installed approximately 50 in. (1270 mm) apart. Install an idler 1 in. (25 mm) before and 1 in. (25mm) after slider cradle. (refer to Figure 2.)
7. Attach stabilizer strap.
8. Mark and attach sub-assemblies to stringers.
9. Fasten slider cradle into place.

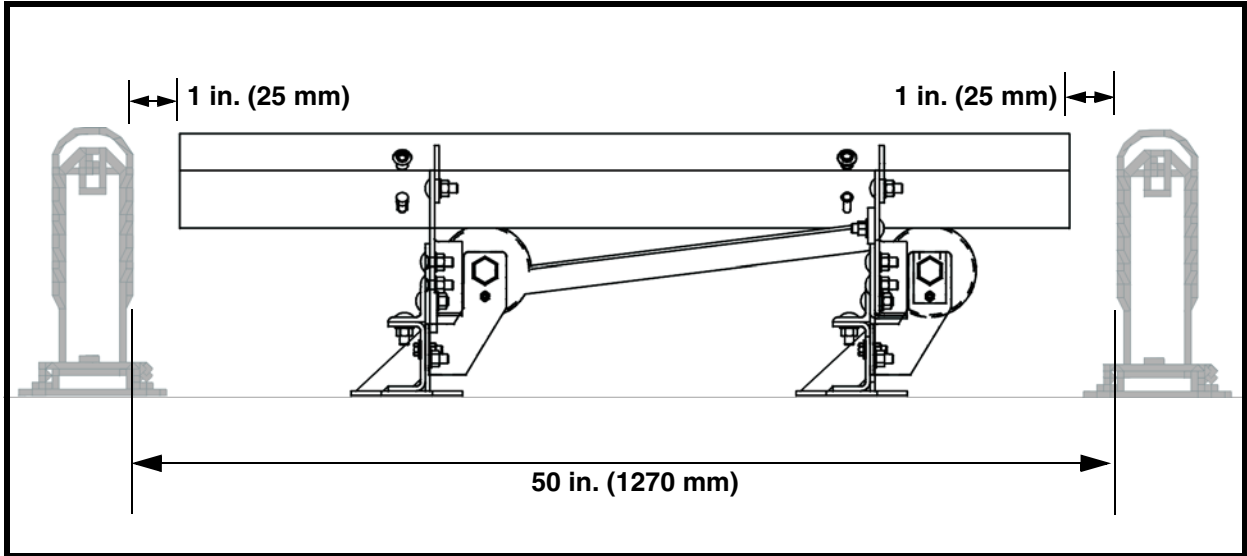

Figure 2. Location of Slider Cradle to Idlers

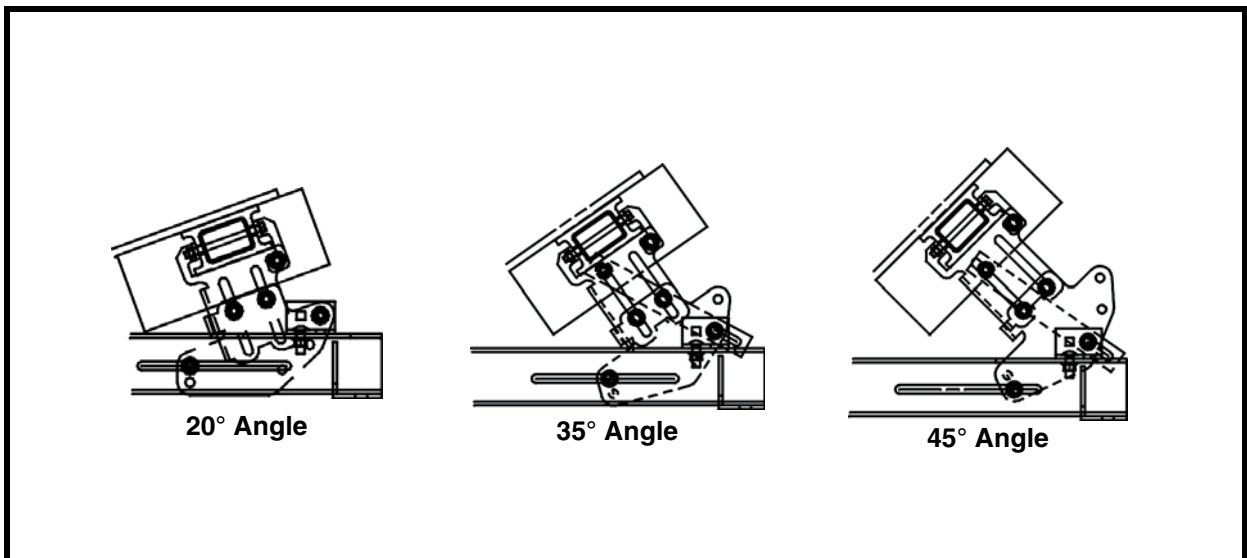

Figure 3. Setting Trough Angle

10. Set trough angle by selecting the proper hole configuration that matches the belt profile (20-, 35-, and 45-degrees), apply bolt, washer and nut, and secure loosely (See Figure 3).

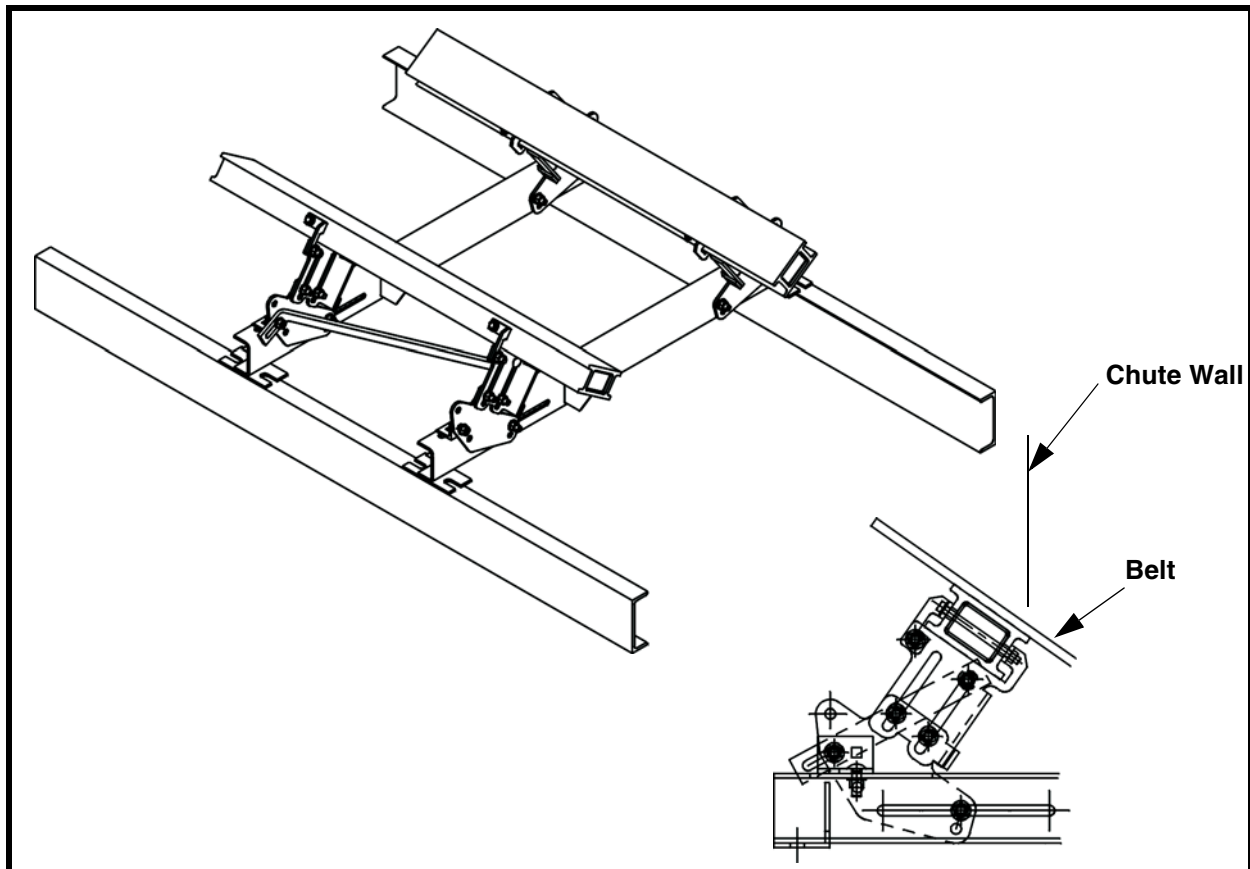

Figure 4. Installing Single-Bar Cradle

11. Position the slider bars so that they are supporting the conveyor belt beneath the chute wall and skirting, if any.
12. Tighten all bolts.
13. Repeat steps 9-12 for opposite side.

NOTE

To ensure proper support, slider bars must be equal dimension on all sides.

Installing Double-Bar Cradle

1. Find center point between idlers and mark point on both stringers.
2. Measure 12 in. (305 mm) from center point in both directions and mark points on both stringers.



3. Place one sub-assembly across the conveyor stringers, placing feet of the support on each conveyor stringer using the reference marks from step 2. Center support rolls are standard with this unit, refer to Table 2 and Figure 6 for mounting details. Brackets should be installed prior to step 3, but can be added during a later step.
4. Place the second sub-assembly across the conveyor stringers as in step 3. Center support weldments on these points across stringers. Place feet of support weldments on stringers. Space approximately 24 in. (610 mm) apart.



5. Install both slider bars, two on each side of the conveyor, making sure holes line up, and fasten down with bolts provided.
6. Center slider cradle between remaining idlers (refer to Figure 1). Idlers should be installed approximately 50 in. (1270 mm) apart. Install an idler 1 in. (25 mm) before and 1 in. (25 mm) after slider cradle. (refer to Figure 2).
7. Attach stabilizer strap.
8. Mark and attach sub-assemblies to stringers.
9. Fasten slider cradle into place.

10. Set trough angle by selecting the proper hole configuration that matches the belt profile (20-, 35-, and 45-degrees), apply bolt, washer and nut, and secure loosely (refer to Figure 3).

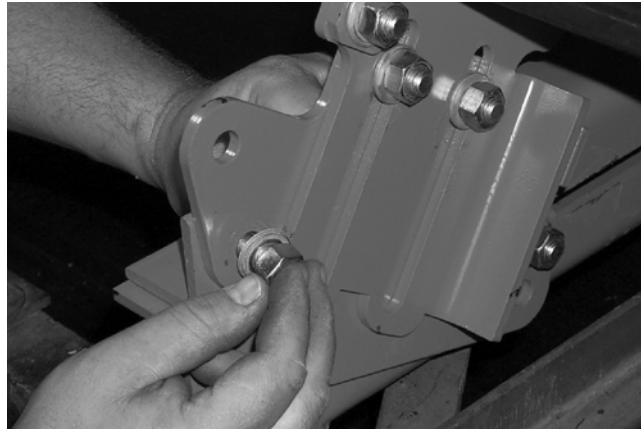

11. Position the slider bars so that they are supporting the conveyor belt beneath the chute wall and skirting, if any.
12. Tighten all bolts.
13. Repeat steps 9-12 for opposite side.

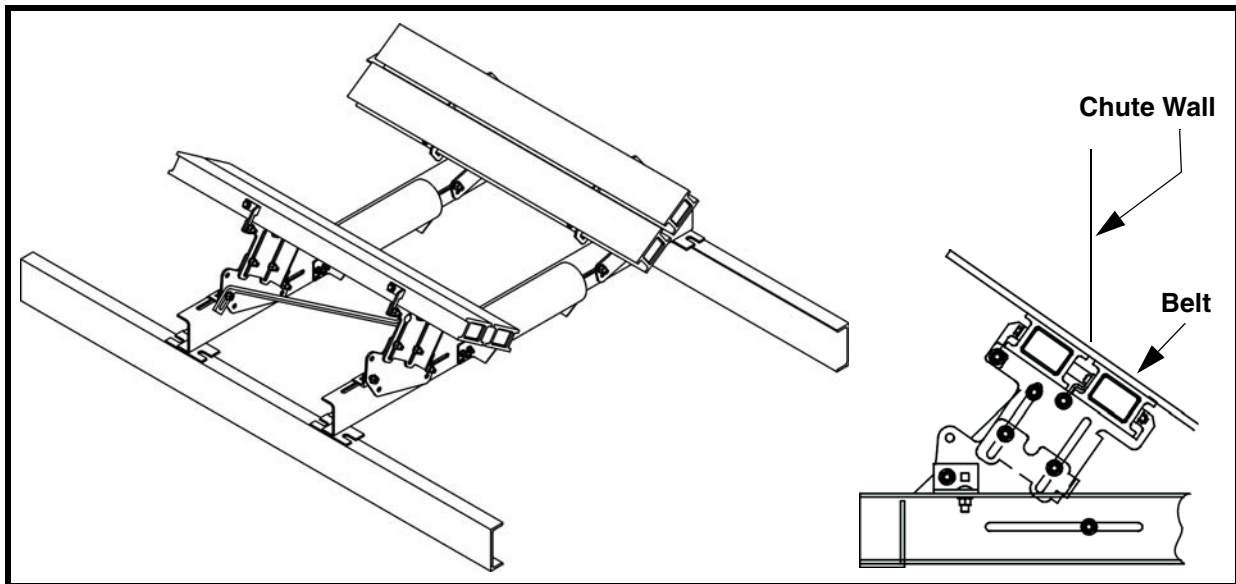

Figure 5. Installing Double-Bar Cradle

**Table II. Center Roll Height Based on CEMA Standards
(Reference Only)**

CEMA Idler Class	Dim. K 30-36-in. Belt inches (mm)	Dim. K 42-48-in. Belt inches (mm)	Dim. K 54-60-in. Belt inches (mm)	Dim. K 72-in. Belt inches (mm)
C4	8.00 (204)	8.50 (216)	8.75 (222)	N/A
C5	8.50 (216)	9.00 (229)	9.25 (235)	N/A
C6	9.00 (229)	9.50 (241)	9.75 (248)	N/A
D5	8.50 (216)	9.00 (229)	9.25 (235)	9.50 (241)
D6	9.00 (229)	9.50 (241)	9.75 (248)	10.00 (254)
E6	10.75 (273) (36 in. Belt only)	10.75 (273)	10.75 (273)	11.50 (292)

Table III. Center Roll Bracket Settings (refer to Figure 6)

Belt Width inches (mm)	Dim. K Lowest Setting inches (mm)	Dim. K Highest Setting inches (mm)
30 (600-800)	8.25 (210)	9.75 (248)
36 (800-1000)	8.25 (210)	9.75 (248)
42 (1000-1200)	8.25 (210)	9.75 (248)
48 (1200-1400)	8.75 (222)	10.25 (260)
54 (1400-1600)	9.50 (241)	11.00 (279)
60 (1600-1800)	9.00 (229)	10.50 (267)
72 (1800-2000)	9.75 (248)	11.25 (286)

NOTE

Brackets are adjustable in .50-in. (13-mm) increments.

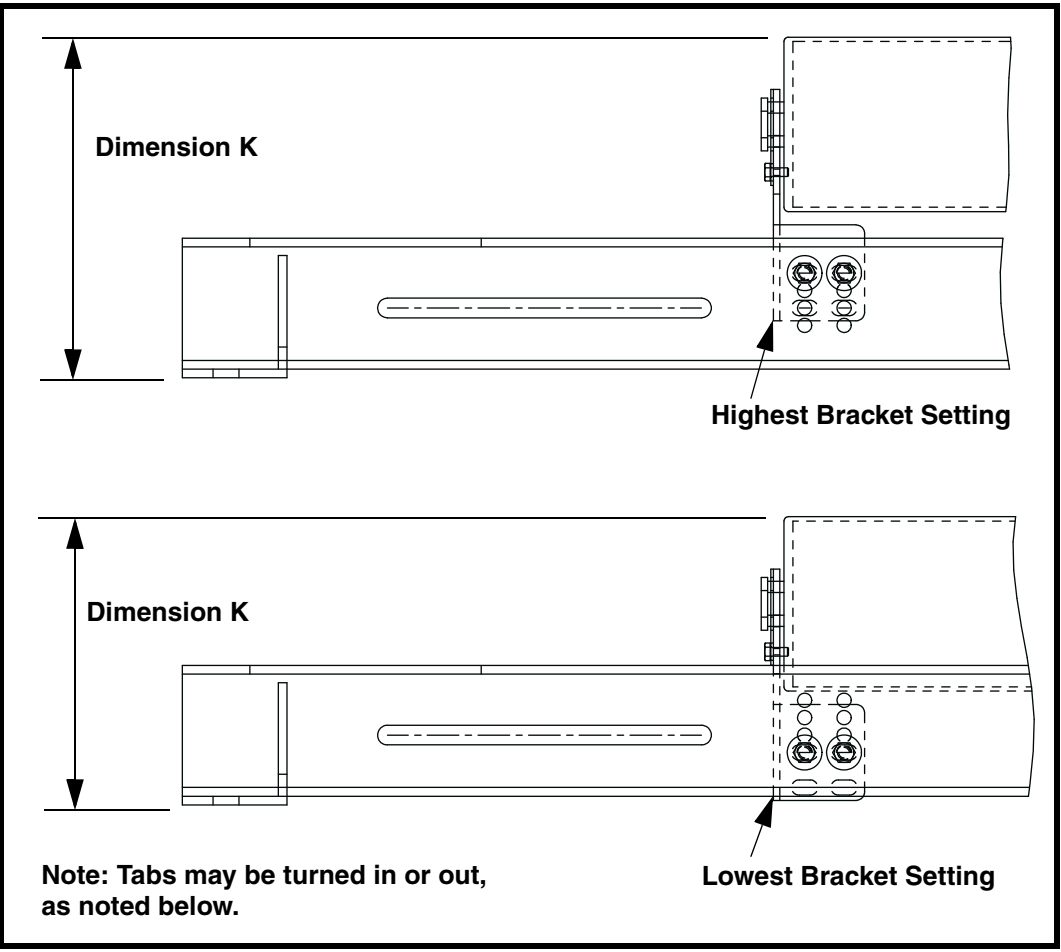

Figure 6. Bracket Settings and Dimensions

Table IV. Idler Support Bracket, Mounting Tabs Direction

Belt Width inches (mm)	Bracket Mounting Tabs Turned
30 (600-800)	IN
36 (800-1000)	IN
42 (1000-1200)	OUT
48 (1200-1400)	OUT
54 (1400-1600)	IN
60 (1600-1800)	OUT
72 (1800-2000)	IN

After Installing Slider Cradle

IMPORTANT

Read entire section before beginning work.

1. Thoroughly wipe outside chute walls clean above slider cradle on both sides of chute. Place a Conveyor Products Warning Label (P/N 23395) on each chute wall visible to belt operator.

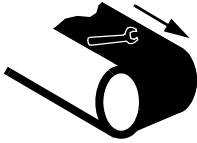

WARNING

Failure to remove tools from installation area and conveyor belt before turning on energy source can cause serious injury to personnel and damage to belt.

2. Remove all tools and fire-retardant cover from installation area and conveyor belt.



DANGER

Do not touch or go near conveyor belt or conveyor accessories when conveyor belt is running. Body or clothing can get caught and pull body into conveyor belt, causing severe injury or death.

3. Turn on conveyor belt for one hour.



DANGER

Before installing, servicing, or adjusting conveyor equipment, turn off and lockout / tagout / blockout / testout all energy sources to the conveyor and conveyor accessories according to ANSI standards. Failure to do so could result in serious injury or death.

4. After one hour of operation, turn off and lockout / tagout / blockout / testout energy source according to ANSI standards (see “References”).
5. Make sure all fasteners are tight. Tighten if necessary.
6. Inspect slider cradle for wear. (A small amount of break-in wear may be found. This will stop once bars wear to conveyor belt contour.)
7. If excessive wear, uneven wear, or some other problem exists, see “Troubleshooting/Installation Checklist.”
8. If necessary, adjust height of bar supports.

IMPORTANT

Read entire section before beginning work.

⚠ DANGER

Before installing, servicing, or adjusting conveyor equipment, turn off and lockout / tagout / blockout / testout all energy sources to the conveyor and conveyor accessories according to ANSI standards. Failure to do so could result in serious injury or death.



Adjusting for Wear

1. Turn off and lockout / tagout / blockout / testout energy source according to ANSI standards (see “References”).
2. Make sure all fasteners are tight. Tighten if necessary.
3. Check slider bars for wear. If worn, do the following:
If bar is not contacting belt but has more than 1/16 in. (2 mm) of material left at support bar, adjust bar height as follows:
 - a. Loosen stop nuts on carriage bolts (see Figure 7, item E).
 - b. Move bar and attaching components towards centerline of belt until bar-to-belt contact occurs.
 - c. Tighten stop nuts on carriage bolts.

Turning Bars Over

1. Remove bolt D on both sub-assemblies.
2. Loosen bolt G and flip bar lock F down.
3. Remove bar and turn upside down.
4. Reinstall. Tighten all bolts.

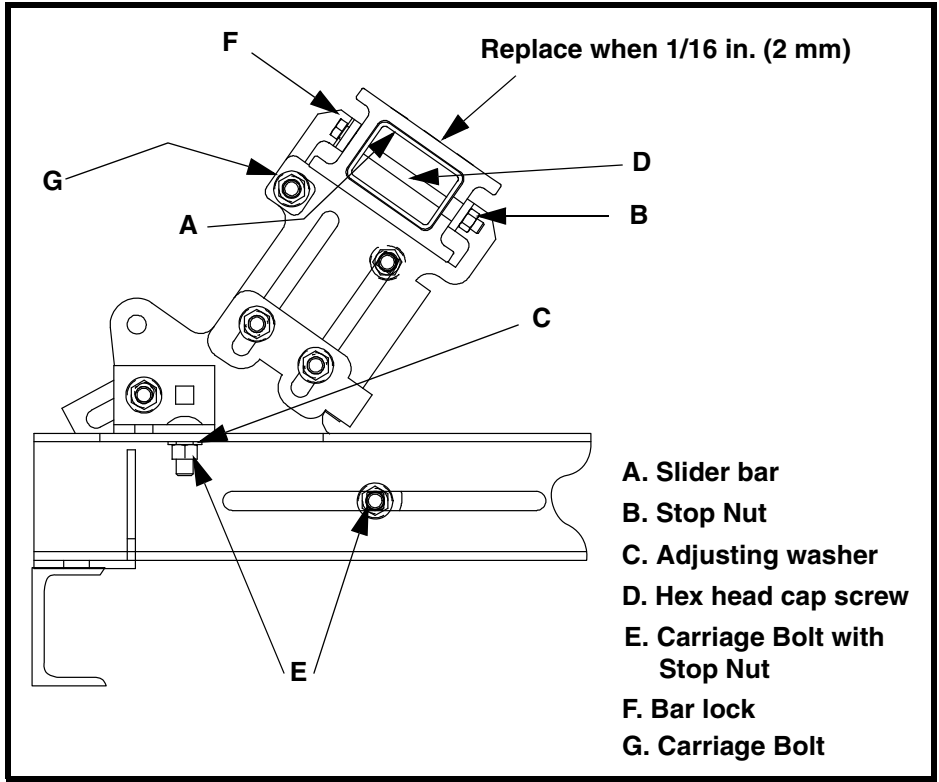
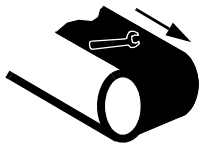

Figure 7. Adjusting or Replacing Slider Bars



⚠ WARNING

Failure to remove tools from installation area and conveyor belt before turning on energy source can cause serious injury to personnel and damage to belt.

- Remove all tools from maintenance area.



⚠ DANGER

Do not touch or go near conveyor belt or conveyor accessories when conveyor belt is running. Body or clothing can get caught and pull body into conveyor belt, causing severe injury or death.

- Start conveyor belt.

Troubleshooting/Installation Checklist

Troubleshooting

If you are experiencing problems with support cradle, see below.

Symptom	Corrective Action
High slider bar wear	Bar is above idler height or is not parallel to belt travel. Adjust bar height or position.
Uneven slider bar wear	Bar is not parallel to belt travel or is under impact. Inspect loading area and divert impact or relocate cradle.

Installation Checklist

If after taking the corrective actions suggested under “Troubleshooting” you are still experiencing problems, check for the following:

Installation Checklist
- Two support weldment or track weldment centers are 13 in. (330 mm) from face to idlers and 24 in. (610 mm) apart.
- Two support rollers are used for belts 48- through 96-in. (1200- through 2400-mm) wide and are centered under belt.
- Slider bars contact belt and follow contour of belt.
- Ends of slider bars are 1 in. (25 mm) from face of idlers.

Notes

Part Numbers

This section provides product names and corresponding part numbers for Martin® Slider Cradles and related equipment. Please reference part numbers when ordering.

Martin® Slider Cradles

Martin® Multi-Trough Design, Single-Bar Slider Cradle:
P/N 36700-18X. See Figures 8a and 8b.

Martin® Multi-Trough Design, Single-Bar Slider Cradle:
P/N 36700-XXX. See Figures 9a and 9b.

Martin® Multi-Trough Design, Double-Bar Slider Cradle:
P/N 36700-XXX. See Figures 10a and 10b.

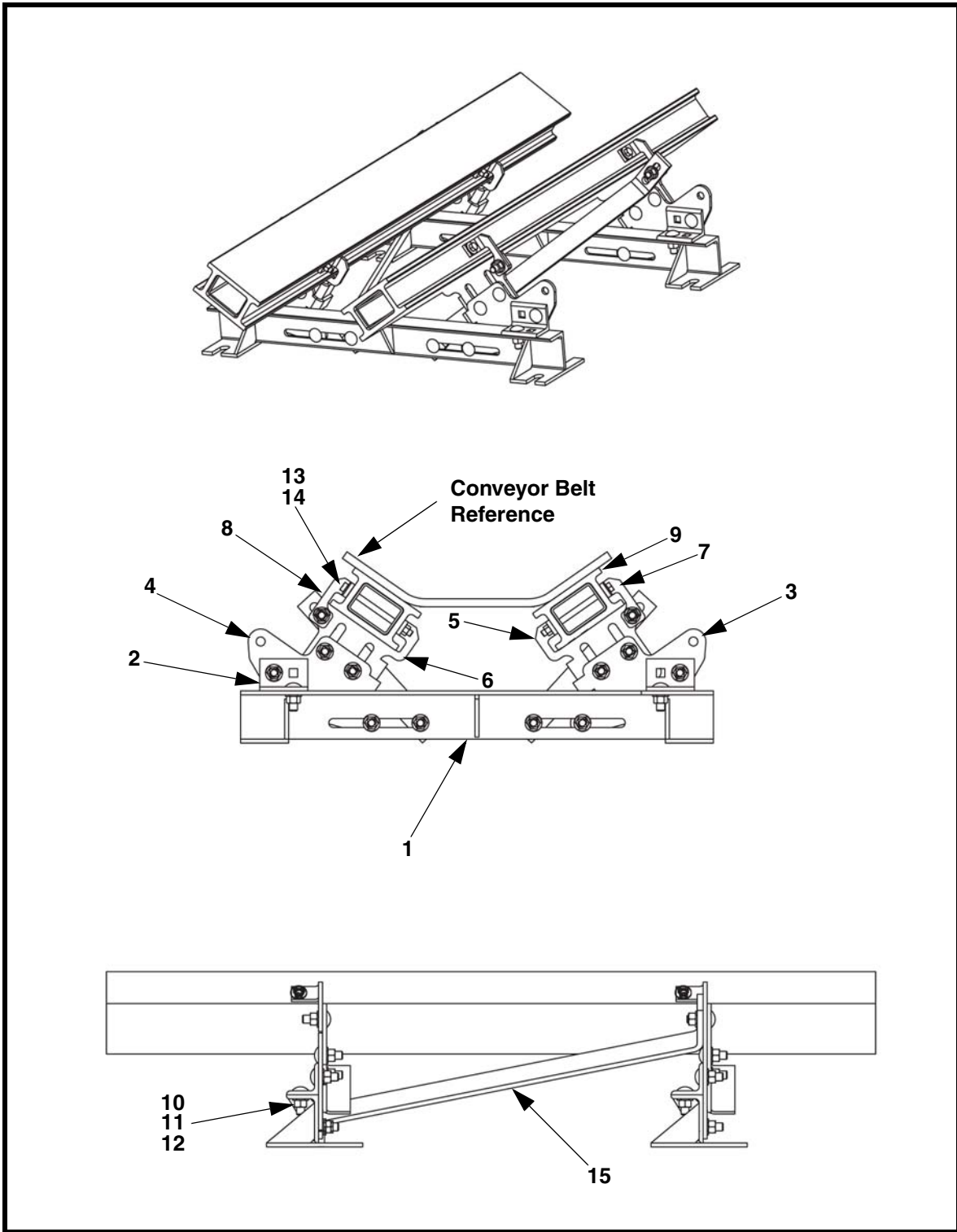

Figure 8a. Martin® Slider Cradle Assembly (Single-Bar), P/N 36700-18X

Item	Description	Part No.	Qty
1	Cross Support Weldment	36716-18X*	2
2	Angle Support	36673	4
3	Wing Plate	36669-18R	2
4	Wing Plate	36669-18L	2
5	Bar Support Weldment	36670-18R	2
6	Bar Support Weldment	36670-18L	2
7	Bar Lock	36672-R	4
8	Bar Lock	36672-L	4
9	Slider and Support Bar Assy	31275	2
10	Bolt Carriage 1/2-13NC ZPx1.50 ZP	33225	26
11	1/2 Compression Washer	11750	26
12	1/2-13NC ZP Nut Hex	11771	26
13	3/8 Wide ZP Flat Washer	18007	4
14	3/8-16 NCx5 ZP Screw	30840	4
15	Stabilizer Strap	36759	2
NS	Mounting Hardware Kit	34498	1
NS	Label Kit	34769	1
NS	Operator's Manual	M3596	1

Figure 8b. Martin[®] Slider Cradle Assembly (Single-Bar), P/N 36700-18X* Parts List

*X Indicates Standard (S) or Wide (W) base.

NS = Not Shown

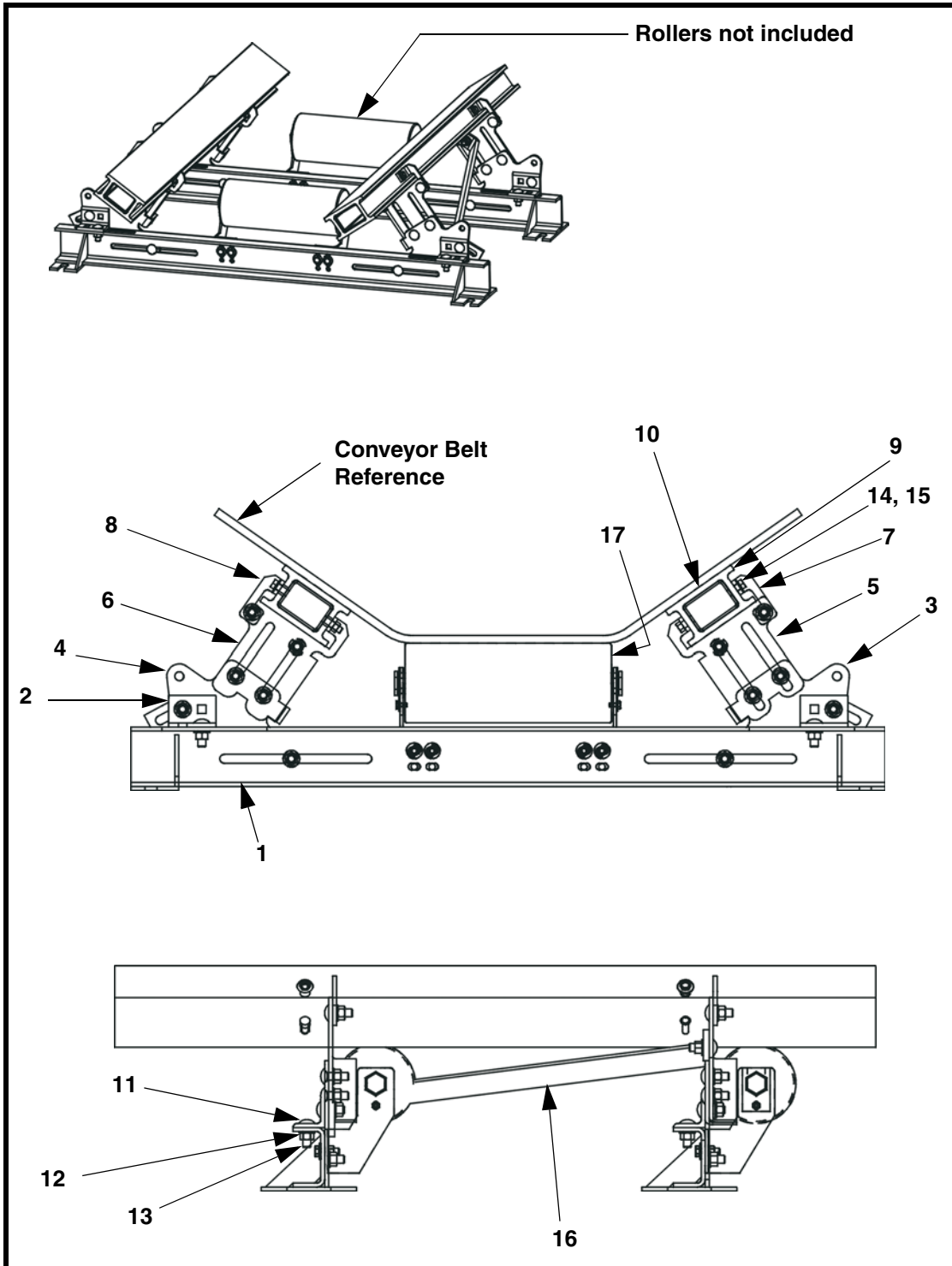

Figure 9a. Martin® Slider Cradle Assembly (Single-Bar), P/N 36700-XXX

Item	Description	Part No.	Qty
1	Cross Support Weldment	Table V	2
2	Angle Support	36673	4
3	Wing Plate	36669-R	2
4	Wing Plate	36669-L	2
5	Bar Support Weldment	36670-R	2
6	Bar Support Weldment	36670-L	2
7	Bar Lock	36672-R	4
8	Bar Lock	36672-L	4
9	Slider Bar	33962	2
10	Inner Bar Support	31213	2
11	Bolt Carriage 1/2-13NC ZPx1.50 ZP	33225	26
12	1/2 Compression Washer	11750	26
13	1/2-13NC ZP Nut Hex	11771	26
14	3/8 Wide ZP Flat Washer	18007	4
15	3/8-16 NCx5 ZP Screw	30840	4
16	Stabilizer Strap	36759	2
17	Support Roll Kit (Optional, not included)	36725	2
NS	Mounting Hardware Kit	34498	1
NS	Label Kit	34769	1
NS	Operator's Manual	M3596	1

Figure 9b. Martin[®] Slider Cradle Assembly (Single-Bar), P/N 36700-XXX Parts List

NS = Not Shown

Table V. Single-Bar Part Numbers and Weights

Part No.	Item 1 P/N	Assembly Weight
36700-24S	36716-24S	120
36700-24W	36716-24W	126
36700-30S	36716-30S	135
36700-30W	36716-30W	141
36700-36S	36716-36S	141
36700-36W	36716-36W	147
36700-42S	36716-42S	156
36700-42W	36716-42W	163

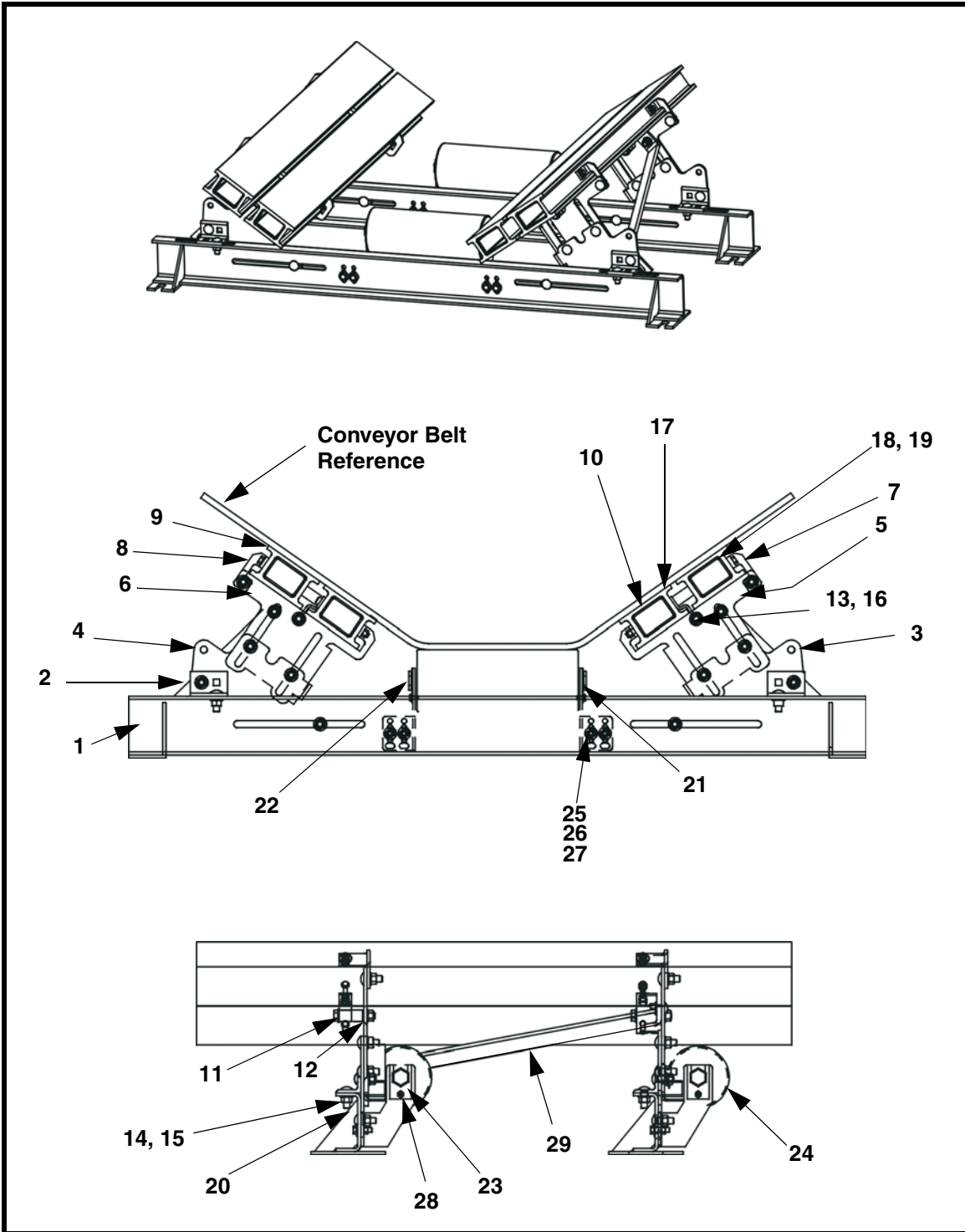

Figure 10a. Martin® Slider Cradle Assembly (Double-Bar), P/N 36700-XXX

Item	Description	Part No.	Qty
1	Cross Support Weldment	Table VI	2
2	Angle Support	36673	4
3	Double-Bar Wing Plate	36697-R	2
4	Double-Bar Wing Plate	36697-L	2
5	Double-Bar Support Weldment	36695-R	2
6	Double-Bar Support Weldment	36695-L	2
7	Bar Lock	36672-R	2
8	Bar Lock	36672-L	2
9	Slider Bar	33962	4
10	Inner Bar Support	31213	4
11	Inner Bail Weldment	36703	4
12	Inner Bail Tube Spacer .88 LG	36701-S	4
13	1/2 Narrow ZP Flat Washer	31010	4
14	1/2 Compression Washer	11750	30
15	1/2-13 NC ZP Hex Nut	11771	30
16	1/2-13 NCx3 ZP Screw	19136	4
17	Inner Bolt Weldment	36699	4
18	3/8 Wide ZP Flat Washer	18007	12
19	3/8-16 NCx4-1/4 ZP Screw	34082	4
20	1/2-13 NCx1-1/2 ZP Carriage Bolt	33225	26
21	Idler Bracket	36694-R	2
22	Idler Bracket	36694-L	2
23	Tie Tab	29852-01	2
24	Idler Roll Assembly	Table VI	2
25	3/8 Compression Washer	11747	8
26	3/8-16 NCx1-1/4 ZP	12215	8
27	3/8-16 NC ZP Hex Nut	11770	8
28	1/4-20 NCx1/2 ZP Screw HHC	11945	4
29	Stabilizer Strap	36759	2
NS	Mounting Hardware Kit	34498	1
NS	Label Kit	34769	1
NS	Operator's Manual	M3596	1

Figure 10b. Martin® Slider Cradle Assembly (Double-Bar), P/N 36700-XXX Parts List

NS = Not Shown

Table VI. Double-Bar Part Numbers and Weights

Part No.	Item 1 P/N	Item 24 P/N	Assembly Weight
36700-48S	36716-48S	32249-07	254
36700-48W	36716-48W	32249-07	261
36700-54S	36716-54S	32249-02	276
36700-54W	36716-54W	32249-02	283
36700-60S	36716-60S	32249-02	298
36700-60W	36716-60W	32249-02	306
36700-72S	36716-72S	32249-03	329
36700-72W	36716-72W	32249-03	340

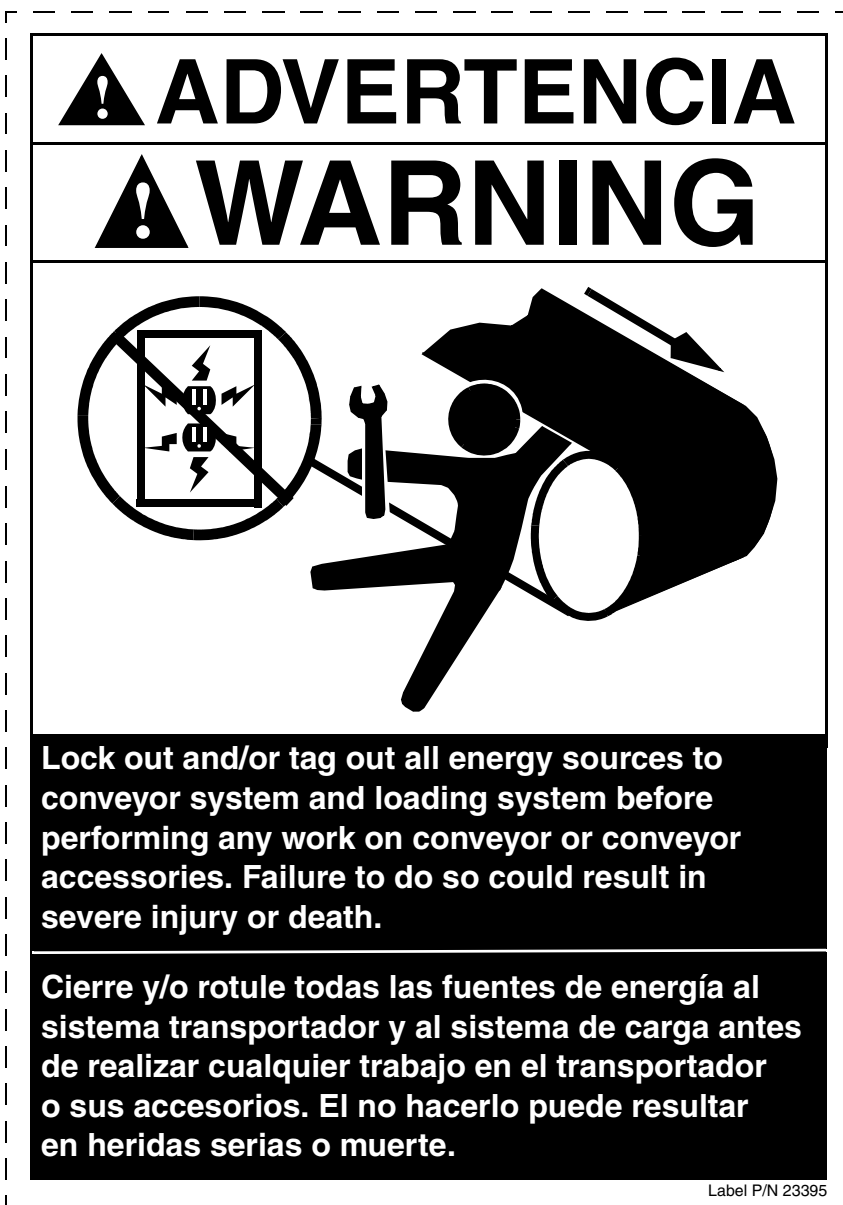
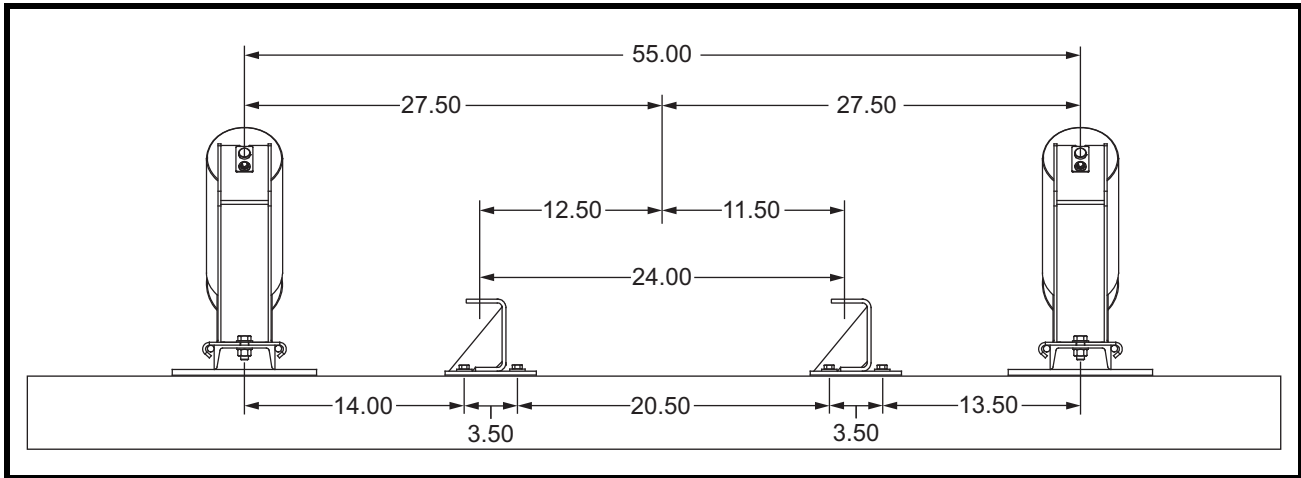
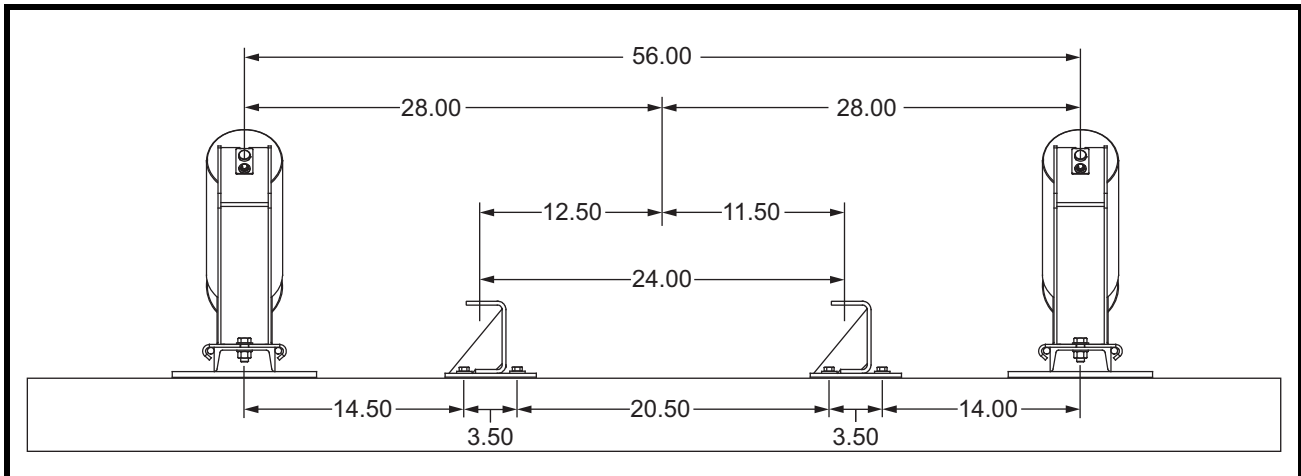

Figure 11. Conveyor Products Warning Label, P/N 23395

Appendix



Martin® Slider Cradle with 5 inch Idlers Mounting Dimensions*



Martin® Slider Cradle with 6 inch Idlers Mounting Dimensions*

*Note: Dimensions do not apply to Martin® Slider Cradles P/N 36700-18X

Any product, process, or technology described here may be the subject of intellectual property rights reserved by Martin Engineering Company. Trademarks or service marks designated with the ® symbol are registered with the U.S. Patent and Trademark Office and may be proprietary in one or more countries or regions. Other trademarks and service marks belonging to Martin Engineering Company in the United States and/or other countries or regions may be designated with the “TM” and “SM” symbols. Brands, trademarks, and names of other parties, who may or may not be affiliated with, connected to, or endorsed by Martin Engineering Company, are identified wherever possible. Additional information regarding Martin Engineering Company’s intellectual property can be obtained at www.martin-eng.com/trademarks.

Problem Solved™ GUARANTEED!

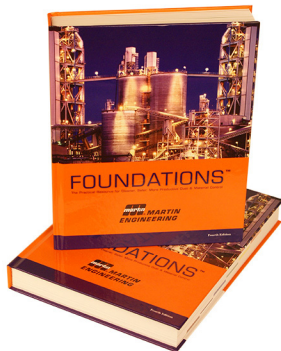

For nearly 20 years, Martin Engineering's Foundations™ Books have taught industry personnel to operate and maintain clean and safe belt conveyors. The Foundations™ Book, fourth edition, focuses on improving belt conveyors by controlling fugitive material. "The Practical Resource for Total Dust and Material Control," is a 576-page hard cover volume that provides information of value to industries where the efficient handling of bulk materials is a key to productivity and profitability.

Expanding upon the book, our Foundations™ Training Program addresses the design and development of more productive belt conveyors, and is offered in three customizable seminars. Attendees gain a better understanding of conveyor safety and performance, helping to justify upgrade investments and increase profitability.



Martin Engineering Australia Pty Ltd.
102 Christensen Road South
Stapylton QLD 4207 - Australia
+61 1300 627 364
salesau@martin-eng.com | www.martin-eng.com.au

