

martin®

Martin® ***Impact Cradles***
LD and MD



Operator's Manual
M3493

Important

MARTIN ENGINEERING HEREBY DISCLAIMS ANY LIABILITY FOR: DAMAGE DUE TO CONTAMINATION OF THE MATERIAL; USER'S FAILURE TO INSPECT, MAINTAIN AND TAKE REASONABLE CARE OF THE EQUIPMENT; INJURIES OR DAMAGE RESULTING FROM USE OR APPLICATION OF THIS PRODUCT CONTRARY TO INSTRUCTIONS AND SPECIFICATIONS CONTAINED HEREIN. MARTIN ENGINEERING'S LIABILITY SHALL BE LIMITED TO REPAIR OR REPLACEMENT OF EQUIPMENT SHOWN TO BE DEFECTIVE.

Observe all safety rules given herein along with owner and Government standards and regulations. Know and understand lockout/tagout procedures as defined by American National Standards Institute (ANSI) z244.1-1982, *American National Standard for Personnel Protection - Lockout/Tagout of Energy Sources - Minimum Safety Requirements* and Occupational Safety and Health Administration (OSHA) Federal Register, Part IV, 29 CFR Part 1910, *Control of Hazardous Energy Source (Lockout/Tagout); Final Rule*.

The following symbols may be used in this manual:



Danger: Immediate hazards that will result in severe personal injury or death.



Warning: Hazards or unsafe practices that could result in personal injury.



Caution: Hazards or unsafe practices that could result in product or property damages.



Important: Instructions that must be followed to ensure proper installation/operation of equipment.



Note: General statements to assist the reader.

Table of Contents

Section	Page
List of Figures	ii
List of Tables	ii
Introduction	1
General	1
References	1
Impact Cradle Materials	1
Safety	1
Materials Required	1
Before Installing Impact Cradles	2
Installing Impact Cradles	3
Measuring Location	3
Installing Impact Bars	4
After Installing Impact Cradle	9
Maintenance	10
Troubleshooting/Installation Checklist	11
Part Numbers	13

List of Figures

Figure	Title	Page
1	Measuring for Martin [®] Impact Cradles	3
2	Installing Martin [®] Impact Cradles	5
3	Martin [®] Impact Cradle LD Assembly, P/N 36010-XXX	14
4	Martin [®] Impact Cradle MD Assembly, P/N 36318-XXX	17
5	Martin [®] Impact Cradle MD Assembly with 5 ft. bars, P/N 36516-XXX.....	20
6	Conveyor Products Warning Label, P/N 23395	23

List of Tables

Table	Title	Page
I	Martin [®] Impact Cradle Materials and Specifications	1
II	Part Numbers and Quantities, Martin [®] Impact Cradle LD.....	16
III	Part Numbers and Quantities, Martin [®] Impact Cradle MD	19
IV	Part Numbers and Quantities, Martin [®] Impact Cradle MD with 5 ft. bars.....	22

Introduction

General

The Martin[®] Impact Cradles LD and MD are layered, shock-absorbing conveyor belt transfer point products engineered for use in bulk solids handling industries.

References

The following documents are referenced in this manual:

- American National Standards Institute (ANSI) z244.1-1982, *American National Standard for Personnel Protection - Lockout/Tagout of Energy Sources - Minimum Safety Requirements*, American National Standards Institute, Inc., 1430 Broadway, New York, NY 10018.
- Federal Register, Volume 54, Number 169, Part IV, 29 CFR Part 1910, *Control of Hazardous Energy Source (Lockout/Tagout); Final Rule*, Department of Labor, Occupational Safety and Health Administration (OSHA), 32nd Floor, Room 3244, 230 South Dearborn Street, Chicago, IL 60604.

Impact Cradle Materials

Materials and specifications for the Martin[®] Impact Cradles are shown in Table I.

Table I. Martin[®] Impact Cradles Materials and Specifications

Characteristics		Bar With UHMW Top
MSHA-Accepted for Underground Use		NA
Coefficient of Friction		0.5
Service Temperature		-20 to 140°F (-29 to 60°C)
Bar Construction	Bearing Layer	UHMW Polyethylene
	Absorption Layer	83A-Durometer Urethane
	T-Slot	Aluminum
	Fasteners	0.5-in. dia. Bolts

Safety

All safety rules defined in the above documents and all owner/employer safety rules must be strictly followed when working on this equipment.

Materials Required

Only standard hand tools are required to install and service this equipment.

Before Installing Impact Cradles

1. Inspect shipping container for damage. Report damage to delivery service immediately and fill out delivery service's claim form. Keep any damaged goods subject to examination.
2. Remove Martin[®] Impact Cradle from shipping container. Equipment in container should include the following:
 - Martin[®] Impact Cradle LD or MD Assembly
 - Two Conveyor Products Warning Labels, P/N 23395
3. If anything is missing or damaged, contact Martin Engineering or a representative.
4. Make sure belt is centered on conveyor.



⚠ WARNING

Before installing equipment, turn off and lock out/tag out energy source to conveyor and conveyor accessories.

5. Turn off and lock out/tag out energy source according to ANSI standards (see "References").

⚠ WARNING

If equipment will be installed in an enclosed area, gas level or dust content must be tested before using a cutting torch or welding. Using a cutting torch or welding in an area with gas or dust may cause an explosion.

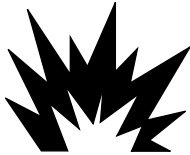

6. If using a cutting torch or welding, test atmosphere for gas level or dust content. Cover conveyor belt with fire retardant cover.
7. If not already present, install an impact idler 1 in. (25 mm) ahead of and 1 in. (25 mm) behind Martin[®] Impact Cradle location.
8. Remove any unnecessary idlers. (The Martin[®] Impact Cradle can replace up to four impact idlers.)

Installing Impact Cradles

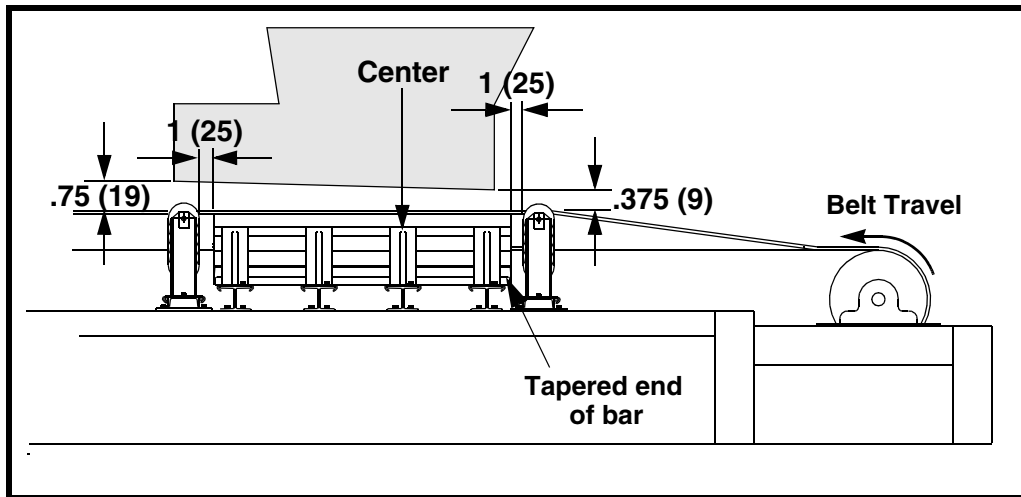

Figure 1. Measuring for Martin[®] Impact Cradles



Measuring Location

1. See Figure 1. Make sure chute walls and/or wear liners are correct distance above belt as shown. If necessary, modify chute walls and/or wear liners.
2. Mark center of loading point on stringer; both sides of belt.
3. Install an idler 1 in. (25 mm) before and 1 in. (25 mm) after Martin[®] Impact Cradle.
4. Measure and align either first cross-support beam or second cross-support beam from tail pulley with center of loading point.

Installing Impact Bars



1. Slide cross-supports under belt in pre-determined location and align with marks.
2. Make sure base weldment cross-supports are perpendicular to belt, or bars will wear unevenly and maintenance will be difficult. Make sure center bars are centered below belt and are parallel to belt travel.
3. Make sure distance from top of center bar to bottom surface of belt measures 1/4 in. (6mm) (see Figure 2). If distance is greater than this, add shims under base weldment to raise impact cradle to height of adjacent idlers. (Shim Kit, P/N 34163 is available from Martin Engineering.) If distance is less than this, contact Martin Engineering or a representative.

NOTE

Martin Engineering recommends bolting rather than welding base weldment to stringers for easier accessibility and maintenance.

4. Bolt or weld base weldment to stringers as follows:
 - a. If bolting, drill or cut 9/16-in. holes in stringers through mounting holes in feet of base weldment cross-supports. Install hex head cap screw, flat washer, compression washer, and hex nut (Figure 2) in each hole to secure base weldment to stringers.
 - b. If welding, clean stringer of rust and dirt. Then stitch weld I-beams to stringers.
5. If removed for installation, install impact bars and/or wing section(s).

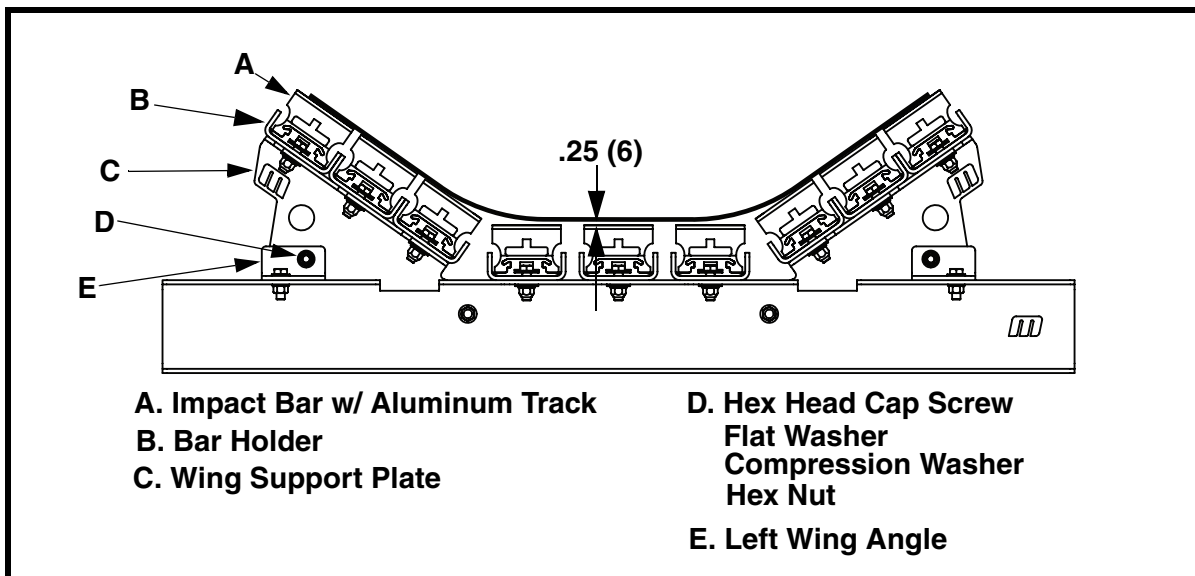

Figure 2. Installing Martin® Impact Cradles



6. Measure the distance from the idler to the first cross member bolt. Verify the dimensions and tighten the bolt into place. (Refer to Figure 3 for Martin® Impact Cradle LD dimensions and Figure 4 for Martin® Impact Cradle MD dimensions.)

Installation



7. Measure between cross support channels. Make sure the cross-support is square.
8. Tighten bolts.
9. Repeat for remaining cross support channels.

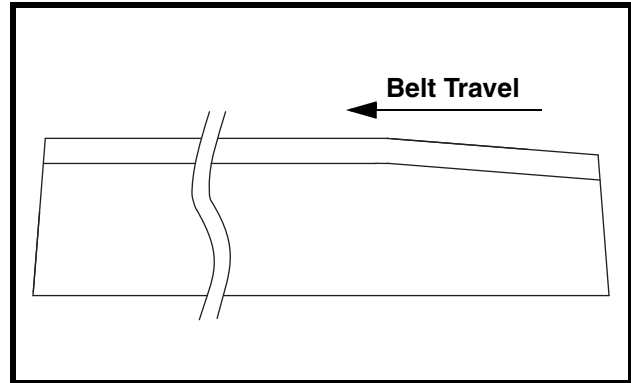

10. Install impact bars. Tapered ends of bars must be located as shown.

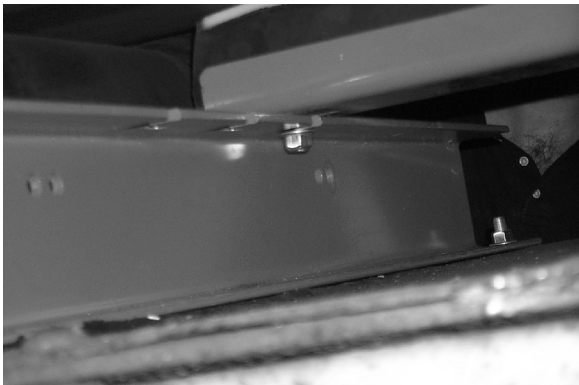

11. Line bolts up with slots and repeat for remaining cross sections. Tighten bolts.
12. Repeat for additional center bars.



13. Bolt wings in the correct holes but do not tighten.

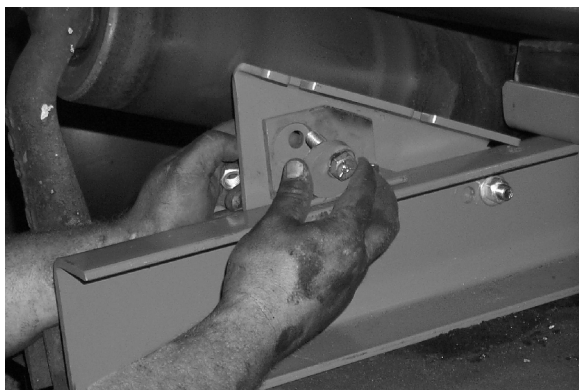

14. Bolt on the fine tune adjustment angle but do not tighten.

15. Bolt on the eccentric angle adjuster but do not tighten.

NOTE

Proper hole selection is important in obtaining the desired troughing angle (e.g., 20°, 35°, 45°).



16. Install impact bars on wings.

Installation



17. Rotate fine adjustment cam until wing bars are touching belt.
18. Tighten bolts.
19. Repeat steps 9–19 for opposite side.

After Installing Impact Cradle

IMPORTANT

Read entire section before beginning work.

1. Thoroughly wipe outside chute walls clean above Martin® Impact Cradle on both sides of chute. Place a Conveyor Products Warning Label (P/N 23395) on each chute wall visible to belt operator.

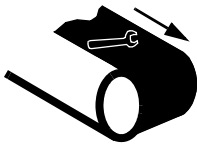

WARNING

Failure to remove tools from installation area and conveyor belt before turning on energy source can cause serious injury to personnel and damage to belt.

2. Remove all tools and fire retardant cover from installation area and conveyor belt.



DANGER

Do not touch or go near conveyor belt or conveyor accessories when conveyor belt is running. Body or clothing can get caught and pull body into conveyor belt, causing severe injury or death.

3. Turn on conveyor belt.



WARNING

Before adjusting impact cradle, turn off and lock out/tag out energy source to conveyor belt and conveyor accessories.

4. After 1 hour of operation, turn off and lock out/tag out energy source according to ANSI standards (see “References”).
5. Make sure all fasteners are tight. Tighten if necessary.
6. Inspect impact bars for wear. (A small amount of “break-in” wear may be found. This will stop once the bars wear to conveyor belt contour.)
7. If excessive wear, uneven wear, or some other problem exists, see “Troubleshooting/ Installation Checklist.”

Maintenance

IMPORTANT

Read entire section before beginning work.



WARNING

Before servicing impact cradle, turn off and lock out/tag out energy source to conveyor belt and conveyor accessories.

1. Turn off and lock out/tag out energy source according to ANSI standards (see “References”).
2. Make sure all fasteners are tight. Tighten if necessary.
3. Check bars for wear. If light-colored top covering on bars is worn through to orange urethane, replace bars as follows:
 - a. If center bars are worn:
 - (1) Remove wing assemblies with bars by removing bolts and set aside for reinstallation.
 - (2) Loosen bolts on impact bars up to and including the worn bars.
 - (3) Remove impact bar and bar holder.
 - (4) Replace worn bars on bar holders and reinstall in reverse order.
 - b. If wing bars are worn:
 - (1) Loosen wing assemblies with bars by removing bolts and slide towards the side of the belt.
 - (2) Loosen bolts on worn impact bars.
 - (3) Remove impact bar and bar holder.
 - (4) Replace worn bars on bar holders and reinstall in reverse order.
4. Remove fines between impact bars with broom or high-pressure air or water.
5. Inspect impact cradle for cracks or fatigue. Weld or strengthen structure as necessary.
6. Wipe warning labels clean. If labels are not readable, contact Martin Engineering or a representative for replacements.

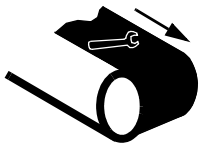

WARNING

Failure to remove tools from maintenance area and conveyor belt before turning on energy source can cause serious injury to personnel and damage to belt.

7. Remove all tools from maintenance area.

DANGER

Do not touch or go near conveyor belt or conveyor accessories when conveyor belt is running. Body or clothing can get caught and pull body into conveyor belt, causing severe injury or death.



8. Start conveyor belt.

Troubleshooting/Installation Checklist

Troubleshooting

If you are experiencing problems with Martin® Impact Cradle, see below:

Symptom	Corrective Action
High impact bar wear rate.	Impact cradle is installed too close to belt. Make sure impact cradle center bars are 1/4 in. (6 mm) below belt.
Impact bars worn unevenly.	Belt is unevenly loaded, wear liners are improperly installed, and/or impact bars are not parallel to belt travel. Inspect loading area and wear liners, and modify transfer point if necessary.

Installation checklist

If after taking corrective actions suggested under “Troubleshooting” you are still experiencing problems, check for the following:

Installation Checklist
Chute walls and/or wear liners are 3/8 in. above belt at tail and 3/4 in. above belt at head.
Second or first I-beam of impact cradle aligns with center of loading point.
An idler is installed under belt 1 in. (25 mm) before and after impact cradle.
Center impact bars are centered below belt and are parallel to belt travel.
Wing sections are aligned with idlers.
Distance from top of center impact bars to bottom of belt surface is 1/4 in. (6 mm).

Part Numbers

This section provides product names and corresponding part numbers for Martin® Impact Cradles LD and MD. Please reference part numbers when ordering parts.

Martin® Impact Cradles

Martin® Impact Cradle LD Assembly, P/N 36010-XXX

Martin® Impact Cradle MD Assembly, P/N 36318-XXX

Martin® Impact Cradle MD Assembly with 5 ft. bars, P/N 36516-XXX

Martin® Wear Liner

P/N WL-XXXXXXXXXXXX. First four Xs indicate the height of wear liner in inches; next four Xs indicate length of wear liner in inches; next three Xs indicate thickness of wear liner in inches; last X indicates wear liner material.

Martin® Slider Cradles

Martin® Slider Cradle: P/N 36700-XXX, for all size belts (18- to 72-in). First XX indicates belt width in inches; last X indicates standard cradle (S) or wide base cradle (W).

Miscellaneous

Shim Kit: P/N 34163.

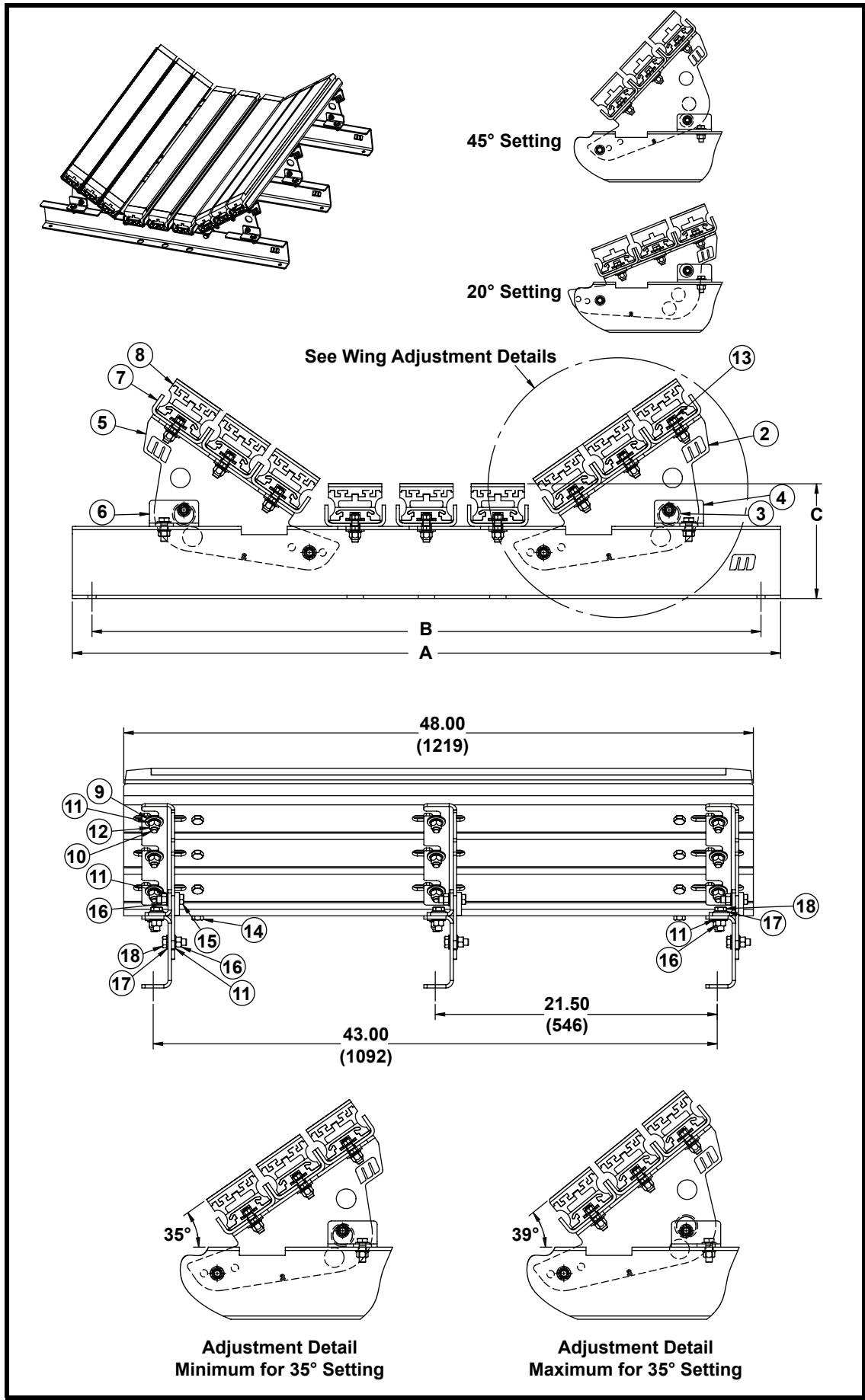

Figure 3. Martin® Impact Cradle LD Assembly, P/N 36010-XXX (Sheet 1 of 2)

Item	Description	Part No.	Qty
1	Cross Support Channel	35990-XXX*	3
2	Wing Support Plate	Table II	3
3	Eccentric Adjustment	35994	6
4	Wing Adjustment Angle Right	35992-R	3
5	Wing Support Plate	Table II	3
6	Wing Adjustment Angle Left	35992-L	3
7	Bar Holder	35991	Table II
8	Impact Bar	39102-4	Table II
9	Washer Flat 1/2 Wide ZP	17328	Table II
10	Screw HHC 1/2-13NC x 1-3/4 ZP	23478	Table II
11	Washer Compression 1/2	11750	Table II
12	Nut Hex Top Lock 1/2-13NC ZP	36215	Table II
13	Nut Hex Flange 1/2-13NC ZP	18843	Table II
14	Screw HHC 1/2-13NC x 1 ZP	13842	Table II
15	Screw HHC 1/2-13NC x 1-3/4 ZP	36228	6
16	Nut Hex 1/2-13NC ZP	11771	18
17	Washer Flat 1/2 Narrow ZP	31010	12
18	Screw HHC 1/2 - 13NC x 1-1/2 ZP	11763	12
19 (NS)	Mounting Hardware	36229	1
20 (NS)	Label Kit	34042	1
21 (NS)	Operator's Manual	M3493	1

* First XX indicates Belt Width. Last X indicates Standard (S) or Wide (W) Base.

NS = Not Shown

Figure 3. Martin® Impact Cradle LD Assembly, P/N 36010-XXX (Sheet 2 of 2)

Table II. Part Numbers and Quantities, Martin® Impact Cradle LD

Part No.	Dim A	Dim B	Dim C	Part No. Item 2	Part No. Item 5	Qty Items 7 & 8	Qty Items 9 & 10	Qty Item 11	Qty Items 12 & 13	Qty Item 14	Wt. (Lbs)
36010-24S	36.00 (914)	33.00 (838)	8.25 (210)	35993-2R	35993-2L	6	12	36	18	36	384
36010-24W	42.00 (1067)	39.00 (991)	8.25 (210)	35993-2R	35993-2L	6	12	36	18	36	395
36010-30S	42.00 (1067)	39.00 (991)	8.25 (210)	35993-2R-1	35993-2L-1	7	14	42	21	39	441
36010-30W	48.00 (1219)	45.00 (1143)	8.25 (210)	35993-2R-1	35993-2L-1	7	14	42	21	39	452
36010-36S	48.00 (1219)	45.00 (1143)	8.25 (210)	35993-2R	35993-2L	7	14	42	21	39	452
36010-36W	54.00 (1372)	51.00 (1295)	8.25 (210)	35993-2R	35993-2L	7	14	42	21	39	463
36010-42S	54.00 (1372)	51.00 (1295)	8.75 (222)	35993-3R	35993-3L	9	18	54	27	45	569
36010-42W	60.00 (1524)	57.00 (1448)	8.75 (222)	35993-3R	35993-3L	9	18	54	27	45	580
36010-48S	60.00 (1524)	57.00 (1448)	8.75 (222)	35993-3R	35993-3L	10	20	60	30	48	626
36010-48W	66.00 (1676)	63.00 (1600)	8.75 (222)	35993-3R	35993-3L	10	20	60	30	48	637

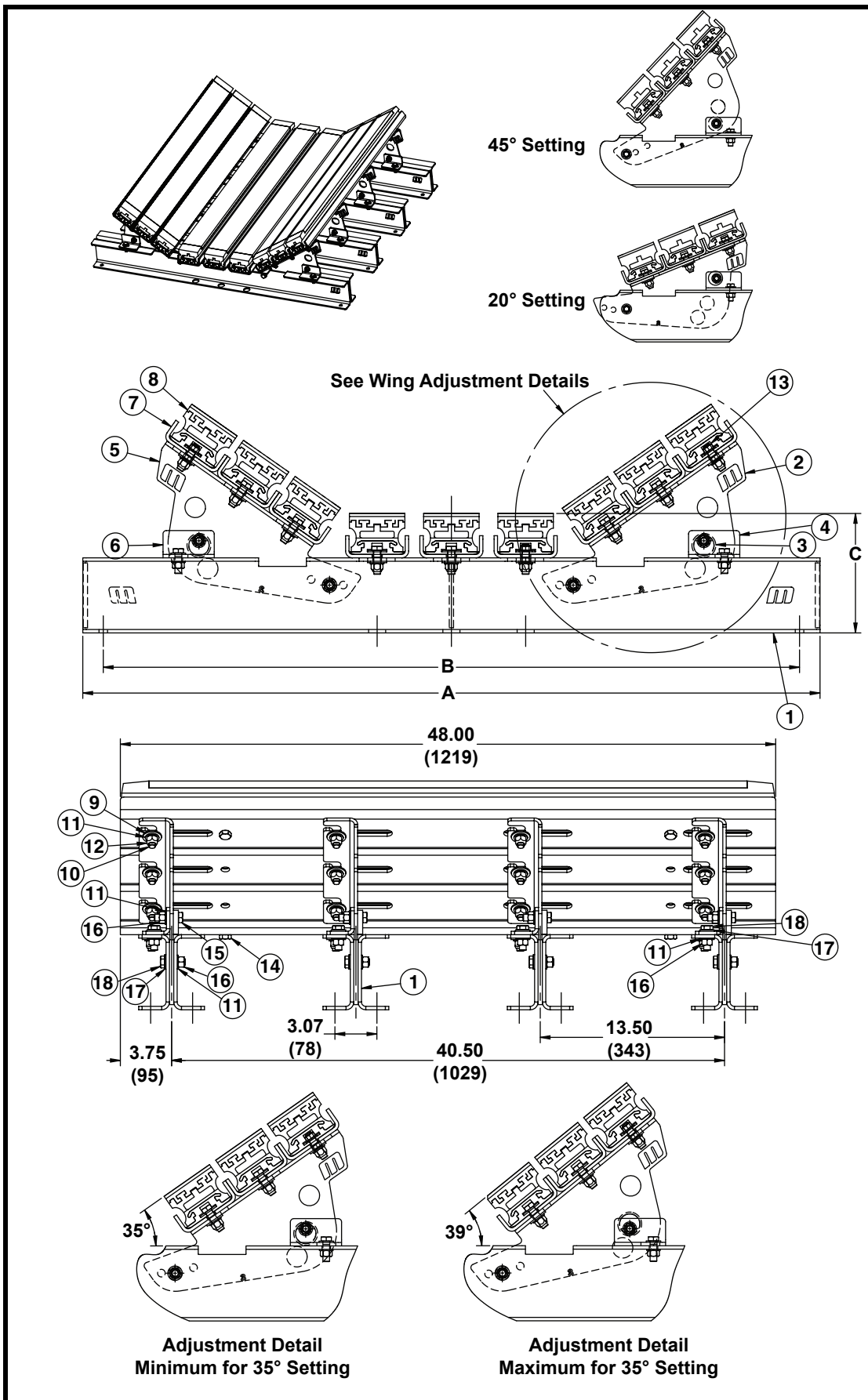

Figure 4. Martin® Impact Cradle MD Assembly, P/N 36318-XXX (Sheet 1 of 2)

Item	Description	Part No.	Qty
1	Cross Support Weldment	36317-XXX*	4
2	Wing Support Plate	Table III	4
3	Eccentric Adjustment	35994	8
4	Wing Angle Right	35992-R	4
5	Wing Support Plate	Table III	4
6	Wing Angle Left	35992-L	4
7	Bar Holder	36324	Table III
8	Urethane Impact Bar	39102-4	Table III
9	Washer Flat 1/2 Wide ZP	17328	Table III
10	Screw HHC 1/2-13NC x 1-3/4 ZP	23478	Table III
11	Washer Compression 1/2	11750	Table III
12	Nut Hex Top Lock 1/2-13NC ZP	36215	Table III
13	Nut Hex Flange 1/2-13NC ZP	18843	Table III
14	Screw HHC 1/2-13NC x 1 ZP	13842	Table III
15	Screw HHC 1/2-13NC x 1-3/4 ZP	36228	8
16	Nut Hex 1/2-13NC ZP	11771	24
17	Washer Flat 1/2 Narrow ZP	31010	16
18	Screw HHC 1/2 - 13NC x 1-1/2 ZP	11763	16
19 (NS)	Mounting Hardware	31033	1
20 (NS)	Label Kit	34042	1
21 (NS)	Operator's Manual	M3493	1

* First XX indicates Belt Width. Last X indicates Standard (S) or Wide (W) Base.

NS = Not Shown

Figure 4. Martin[®] Impact Cradle MD Assembly, P/N 36318-XXX (Sheet 2 of 2)

Table III. Part Numbers and Quantities, Martin® Impact Cradle MD

Part No.	Dim A	Dim B	Dim C	Part No. Item 2	Part No. Item 5	Qty Items 7 & 8	Qty Item 9	Qty Items 10 & 12	Qty Item 11	Qty Items 13 & 14	Wt. (Lbs)
36318-24S	36.00 (914)	33.00 (838)	8.25 (210)	35993-2R	35993-2L	6	48	24	48	12	501
36318-24W	42.00 (1067)	39.00 (991)	8.25 (210)	35993-2R	35993-2L	6	48	24	48	12	530
36318-30S	42.00 (1067)	39.00 (991)	8.25 (210)	35993-2R-1	35993-2L-1	7	56	28	52	14	574
36318-30W	48.00 (1219)	45.00 (1143)	8.25 (210)	35993-2R-1	35993-2L-1	7	56	28	52	14	604
36318-36S	48.00 (1219)	45.00 (1143)	8.25 (210)	35993-2R	35993-2L	7	56	28	52	14	604
36318-36W	54.00 (1372)	51.00 (1295)	8.25 (210)	35993-2R	35993-2L	7	56	28	52	14	633
36318-42S	54.00 (1372)	51.00 (1295)	8.75 (222)	35993-3R	35993-3L	9	72	36	60	18	750
36318-42W	60.00 (1524)	57.00 (1448)	8.75 (222)	35993-3R	35993-3L	9	72	36	60	18	781
36318-48S	60.00 (1524)	57.00 (1448)	8.75 (222)	35993-3R	35993-3L	10	80	40	64	20	825
36318-48W	66.00 (1676)	63.00 (1600)	8.75 (222)	35993-3R	35993-3L	10	80	40	64	20	856
36318-54S	66.00 (1676)	63.00 (1600)	9.00 (229)	35993-4R	35993-4L	12	96	48	72	24	971
36318-54W	72.00 (1829)	69.00 (1753)	9.00 (229)	35993-4R	35993-4L	12	96	48	72	24	1003
36318-60S	72.00 (1829)	69.00 (1753)	9.00 (229)	35993-4R	35993-4L	13	104	52	76	26	1047
36318-60W	78.00 (1981)	75.00 (1905)	9.00 (229)	35993-4R	35993-4L	13	104	52	76	26	1079
36318-66S	78.00 (1981)	75.00 (1905)	9.25 (235)	35993-5R	35993-5L	15	120	60	84	30	1210
36318-66W	84.00 (2134)	81.00 (2057)	9.25 (235)	35993-5R	35993-5L	15	120	60	84	30	1243
36318-72S	84.00 (2134)	81.00 (2057)	9.25 (235)	35993-5R	35993-5L	16	128	64	88	32	1287
36318-72W	90.00 (2286)	87.00 (2210)	9.25 (235)	35993-5R	35993-5L	16	128	64	88	32	1320

Part Numbers

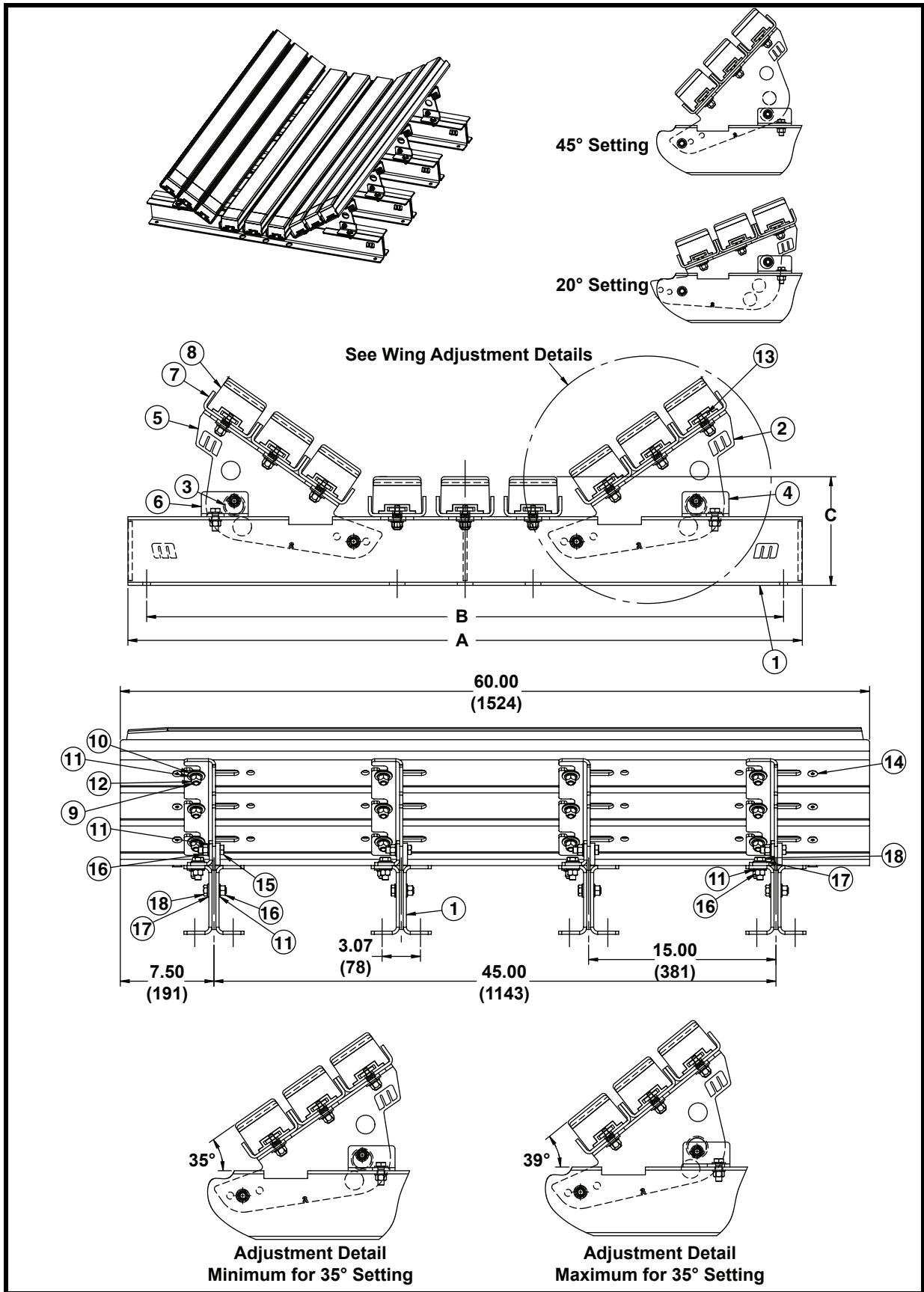

Figure 5. Martin® Impact Cradle MD Assembly with 5 ft. bars, P/N 36516-XXX (Sheet 1 of 2)

Item	Description	Part No.	Qty
1	Cross Support Weldment	36317-XXX*	4
2	Wing Support Plate	Table IV	4
3	Eccentric Adjustment	Table IV	8
4	Wing Adjustment Angle - Right	35992-R	4
5	Wing Support Plate	Table IV	4
6	Wing Adjustment Angle - Left	35992-L	4
7	Bar Holder (5 ft.)	36519	Table IV
8	Impact Bar w/ Aluminum Track (5 ft.)	33816	Table IV
9	T-Bolt 1/2 - 13NC x 1-1/2	31775	Table IV
10	Washer Flat 1/2 Wide ZP	17328	Table IV
11	Washer Compression 1/2	11750	Table IV
12	Nut Hex Top Lock 1/2 - 13NC ZP	36215	Table IV
13	Plate Nut 3/8-16NC	37387	Table IV
14	Screw HSFCHC 3/8-16NC x 1	32900	Table IV
15	Screw HHC 1/2-13NC x 1-3/4 ZP	36228	8
16	Nut Hex 1/2-13NC ZP	11771	24
17	Washer Flat 1/2 Narrow ZP	31010	16
18	Screw HHC 1/2-13NC x 1-1/2 ZP	11763	16
19 (NS)	Mounting Hardware	31033	1
20 (NS)	Label Kit	34042	1
21 (NS)	Operator's Manual	M3493	1

* First XX indicates Belt Width. Last X indicates Standard (S) or Wide (W) Base.

NS = Not Shown

Figure 5. Martin[®] Impact Cradle MD Assembly with 5 ft. bars, P/N 36516-XXX (Sheet 2 of 2)

Table IV. Part Numbers and Quantities, Martin® Impact Cradle MD with 5 ft. bars

Part No.	Dim A	Dim B	Dim C	Part No. Item 2	Part No. Item 5	Qty Items 7 & 8	Qty Items 9, 10, 12	Qty Item 11	Qty Items 13 & 14	Wt. (Lbs)
36516-24S	36.00 (914)	33.00 (838)	8.20 (208)	35993-2R	35993-2L	6	24	48	12	562
36516-24W	42.00 (1067)	39.00 (991)	8.20 (208)	35993-2R	35993-2L	6	24	48	12	592
36516-30S	42.00 (1067)	39.00 (991)	8.20 (208)	35993-2R-1	35993-2L-1	7	28	52	14	647
36516-30W	48.00 (1219)	45.00 (1143)	8.20 (208)	35993-2R-1	35993-2L-1	7	28	52	14	676
36516-36S	48.00 (1219)	45.00 (1143)	8.20 (208)	35993-2R	35993-2L	7	28	52	14	676
36516-36W	54.00 (1372)	51.00 (1295)	8.20 (208)	35993-2R	35993-2L	7	28	52	14	705
36516-42S	54.00 (1372)	51.00 (1295)	8.70 (221)	35993-3R	35993-3L	9	36	60	18	844
36516-42W	60.00 (1524)	57.00 (1448)	8.70 (221)	35993-3R	35993-3L	9	36	60	18	875
36516-48S	60.00 (1524)	57.00 (1448)	8.70 (221)	35993-3R	35993-3L	10	40	64	20	930
36516-48W	66.00 (1676)	63.00 (1600)	8.70 (221)	35993-3R	35993-3L	10	40	64	20	961
36516-54S	66.00 (1676)	63.00 (1600)	8.95 (227)	35993-4R	35993-4L	12	48	72	24	1096
36516-54W	72.00 (1829)	69.00 (1753)	8.95 (227)	35993-4R	35993-4L	12	48	72	24	1128
36516-60S	72.00 (1829)	69.00 (1753)	8.95 (227)	35993-4R	35993-4L	13	52	76	26	1183
36516-60W	78.00 (1981)	75.00 (1905)	8.95 (227)	35993-4R	35993-4L	13	52	76	26	1215
36516-72S	84.00 (2134)	81.00 (2057)	9.20 (234)	35993-5R	35993-5L	16	64	88	32	1455
36516-72W	90.00 (2286)	87.00 (2210)	9.20 (234)	35993-5R	35993-5L	16	64	88	32	1488

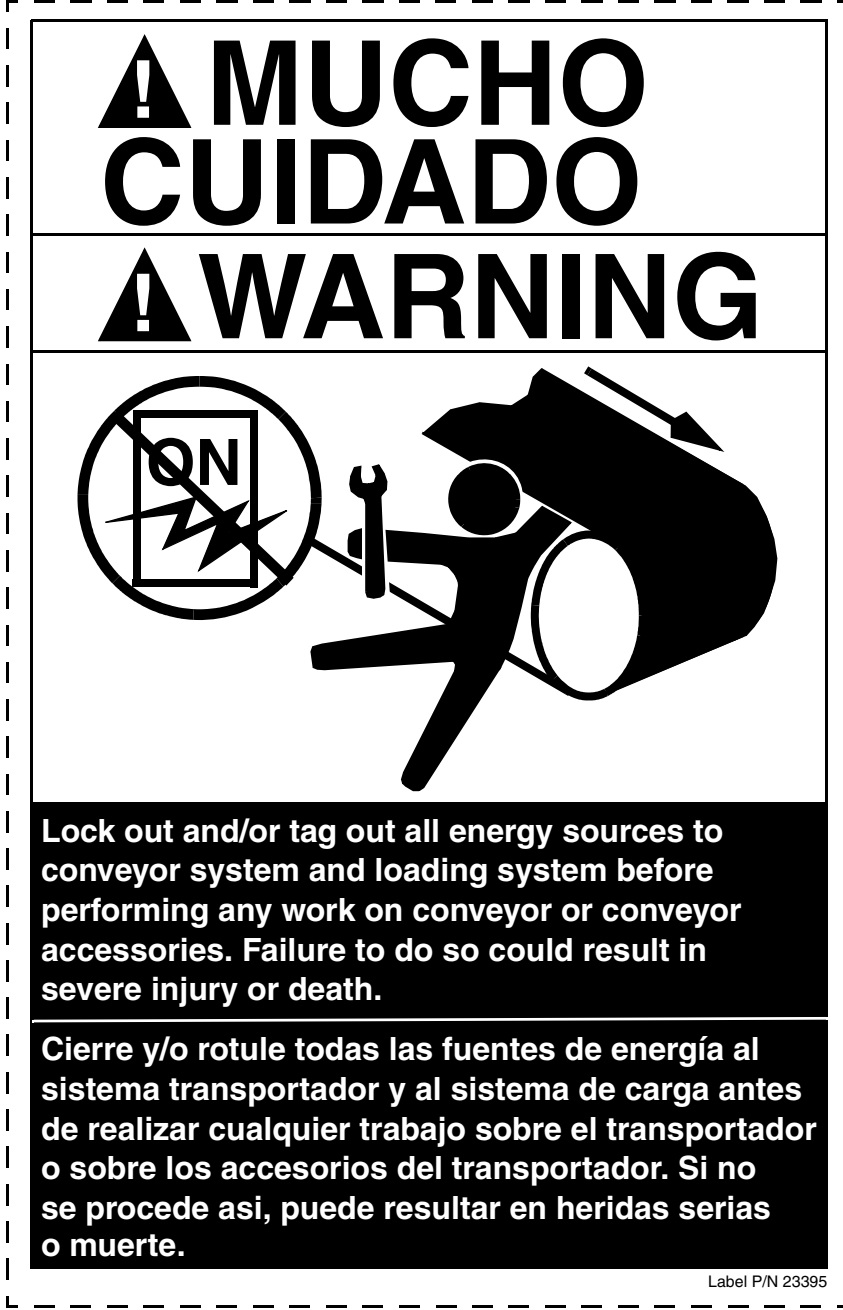
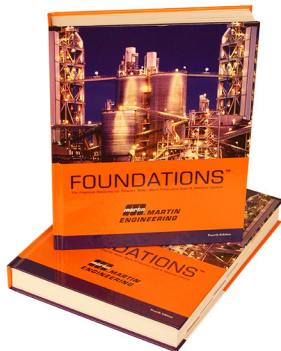

Figure 6. Conveyor Products Warning Label, P/N 23395

Any product, process, or technology described here may be the subject of intellectual property rights reserved by Martin Engineering Company. Trademarks or service marks designated with the ® symbol are registered with the U.S. Patent and Trademark Office and may be proprietary in one or more countries or regions. Other trademarks and service marks belonging to Martin Engineering Company in the United States and/or other countries or regions may be designated with the “TM” and “SM” symbols. Brands, trademarks, and names of other parties, who may or may not be affiliated with, connected to, or endorsed by Martin Engineering Company, are identified wherever possible. Additional information regarding Martin Engineering Company’s intellectual property can be obtained at www.martin-eng.com/trademarks.

Problem Solved™ GUARANTEED!



For nearly 20 years, Martin Engineering's Foundations™ Books have taught industry personnel to operate and maintain clean and safe belt conveyors. The Foundations™ Book, fourth edition, focuses on improving belt conveyors by controlling fugitive material. "The Practical Resource for Total Dust and Material Control," is a 576-page hard cover volume that provides information of value to industries where the efficient handling of bulk materials is a key to productivity and profitability.

Expanding upon the book, our Foundations™ Training Program addresses the design and development of more productive belt conveyors, and is offered in three customizable seminars. Attendees gain a better understanding of conveyor safety and performance, helping to justify upgrade investments and increase profitability.



Martin Engineering Australia Pty Ltd.
102 Christensen Road South
Stapylton QLD 4207 - Australia
+61 1300 627 364
salesau@martin-eng.com | www.martin-eng.com.au

