

***martin***®

***Martin® Hurricane  
Air Cannon***



***Operator's Manual  
M3737***

# Important

MARTIN ENGINEERING HEREBY DISCLAIMS ANY LIABILITY FOR: DAMAGE DUE TO CONTAMINATION OF THE MATERIAL; USER'S FAILURE TO INSPECT, MAINTAIN AND TAKE REASONABLE CARE OF THE EQUIPMENT; INJURIES OR DAMAGE RESULTING FROM USE OR APPLICATION OF THIS PRODUCT CONTRARY TO INSTRUCTIONS AND SPECIFICATIONS CONTAINED HEREIN. MARTIN ENGINEERING'S LIABILITY SHALL BE LIMITED TO REPAIR OR REPLACEMENT OF EQUIPMENT SHOWN TO BE DEFECTIVE.

Observe all safety rules given herein along with owner and Government standards and regulations. Know and understand lockout/tagout procedures as defined by American National Standards Institute (ANSI) z244.1-1982, *American National Standard for Personnel Protection - Lockout/Tagout of Energy Sources - Minimum Safety Requirements* and Occupational Safety and Health Administration (OSHA) Federal Register, Part IV, 29 CFR Part 1910, *Control of Hazardous Energy Source (Lockout/Tagout); Final Rule*.

The following symbols may be used in this manual:



**Danger:** Immediate hazards that will result in severe personal injury or death.



**Warning:** Hazards or unsafe practices that could result in personal injury.



**Caution:** Hazards or unsafe practices that could result in product or property damages.



**Important:** Instructions that must be followed to ensure proper installation/operation of equipment.



**Note:** General statements to assist the reader.

# Table of Contents

---

<b>Section</b>	<b>Page</b>
List of Figures . . . . .	ii
Introduction . . . . .	1
General . . . . .	1
Operation . . . . .	1
Tank data . . . . .	2
Model and serial numbers . . . . .	2
Required accessories . . . . .	2
Specifications . . . . .	3
References . . . . .	3
Safety . . . . .	3
Materials required . . . . .	3
Before Installing Air Cannon. . . . .	4
Installing Air Cannon . . . . .	6
Installing mounting plate . . . . .	6
Connecting air cannon to mounting plate . . . . .	11
Installing restraining cable . . . . .	11
Connecting air supply to air cannon. . . . .	12
After Installing Air Cannon. . . . .	18
Maintenance. . . . .	20
Monthly inspection. . . . .	20
Periodic maintenance . . . . .	21
Air Cannon Valve Assembly Replacement . . . . .	21
Troubleshooting. . . . .	25
Part Numbers . . . . .	26
Air Cannons . . . . .	26
Air Cannon Repair Parts . . . . .	26
Appendix A. Martin <sup>®</sup> Hurricane Air Cannon Specifications and Performance Data . . . . .	A-1

## List of Figures

---

<b>Figure</b>	<b>Title</b>	<b>Page</b>
1	Restricted Material .....	1
2	Air Cannon Charging and Discharging .....	1
3	Serial and Model Number Plate .....	2
4	Air Cannon Accessories .....	2
5	Air Cannon Mounting Orientation .....	5
6	Installing 30-Degree Mounting Plate .....	7
7	Installing a Drop-Through 30-Degree Mounting Plate for Vessels with Liner	7
8	Mounting Nozzles/Pipes for High-Temperature Applications .....	8
9	Installing Martin <sup>®</sup> SMART <sup>™</sup> Series Jet Nozzle for High-Temperature Applications .....	9
10	Riser Duct with Fan Nozzles for High-Temperature Applications .....	9
11	Installing Stainless Steel Blow Pipe and Carbon Steel Blow Pipe for High-Temperature Applications .....	10
12	Cyclone with High-Temperature Blow Pipes .....	10
13	Flange Installation .....	11
14	Installing Restraining Cable .....	12
15	Plumbing Detail for Normally-Opened Solenoid Valve .....	15
16	Plumbing Detail for Normally-Closed Solenoid Valve .....	16
17	Plumbing Detail for Ten Bank Solenoid Cabinet .....	17
18	Martin <sup>®</sup> Hurricane Air Cannon Assembly Parts List .....	27
19	Martin <sup>®</sup> Hurricane Air Cannon Valve Rebuild Kit, P/N 38137-4 .....	28
20	Martin <sup>®</sup> Hurricane Air Cannon Exhaust Valve Cap Replacement Kit, P/N 38137-4 .....	29
21	Martin <sup>®</sup> Hurricane Air Cannon Main Piston Rebuild Kit, P/N 38426 .....	30
22	Air Cannon Air Fill Kit, P/N 37890-XX .....	31
23	Air Cannon Warning Label, P/N 33439 .....	32
24	Martin <sup>®</sup> Serial/Model Number Label, P/N 21313 .....	32
25	Air Blast Warning Label, P/N 31913 .....	33
26	Loud Noise Warning Tag, P/N 34070 .....	34

# Introduction

## General

The Martin<sup>®</sup> Hurricane Air Cannon is a pneumatic bulk material-moving system that quickly releases compressed air into storage vessels, transfer chutes, gas ducts, and feed pipes to maintain and/or restore material or gas flow to material that is clinging (A), bridging (B), rat-holing (C), or arching (D) (see Figure 1).

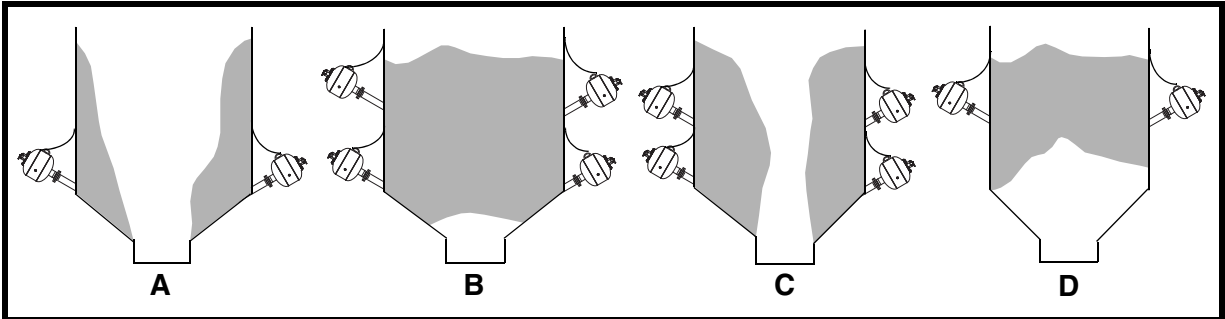
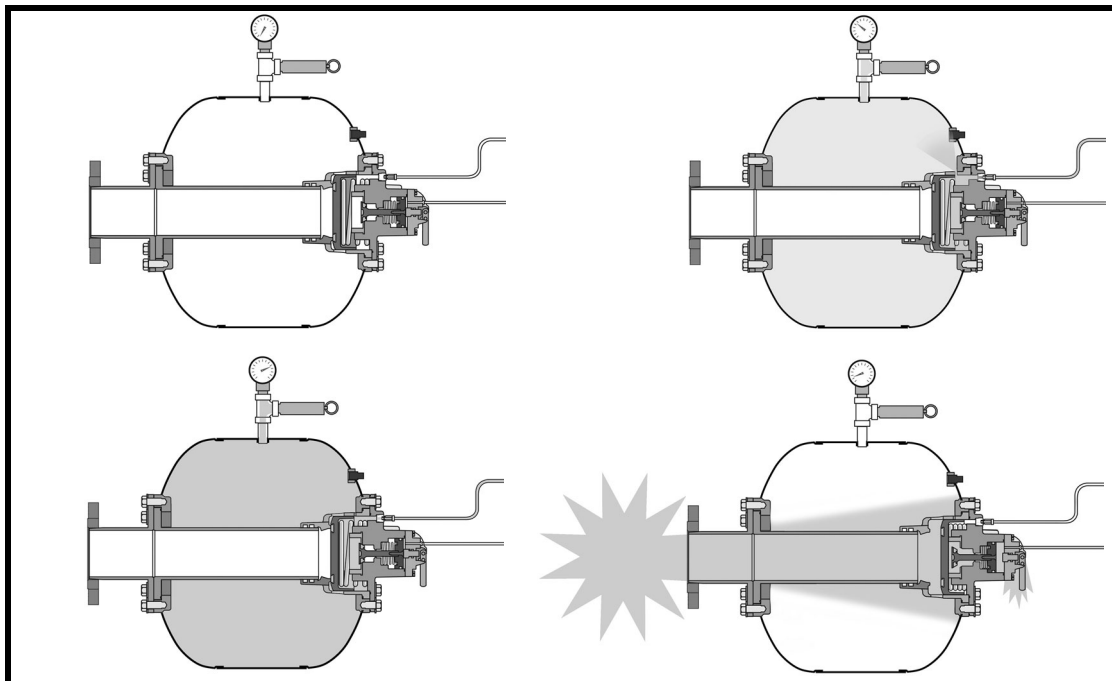

**Figure 1. Restricted Material**

This manual provides instructions for installing air cannons on steel structures only. For installations on other structures, call Martin Engineering or a representative.

## Operation

The Martin<sup>®</sup> Hurricane Air Cannon System consists of one or more air cannons mounted on a storage or process vessel. The air cannon charges when the tank is filled with compressed air or nitrogen between 10 psi and 125 psi operating pressure (up to 150 psi available upon request). When the tank pressure equals the line pressure, airflow is static and the air cannon is ready to be discharged. By activating the solenoid valve, a positive pressure signal is sent to the Martin<sup>®</sup> Hurricane Air Cannon Exhaust Valve causing it to actuate and release the pressure holding the piston. The piston is instantly forced back by the air pressure stored in the tank. The blast of air is then directed through the discharge pipe or nozzle and into the storage or process vessel.



**Figure 2. Air Cannon Charging and Discharging**

**IMPORTANT**

**Tank data**

**Never weld tank. Welding will melt paint and violate ASME coding.**

The air cannon tank is manufactured to American Society of Mechanical Engineers (ASME) Code Rules, Section VIII, Division 1. It is National Board registered and is pressure vessel quality (PVQ). After the tank is welded, paint is applied inside the tank to prevent rust and corrosion. **Never weld tank.** Welding will melt paint and violate ASME coding.

**Model and serial numbers**

Each air cannon's serial and model number is shown on a plate attached to the tank (see Figure 3). Serial and model numbers must be referenced when ordering parts from Martin Engineering or representative, and on all correspondence.



**Figure 3. Serial and Model Number Plate Example**

**Required accessories**

An air cannon system requires additional accessories in order to be fully operational. These accessories, which consist of solenoid valves, filters, regulators, air pressure gauges, ball valves, air hoses, mounting plates, nozzles, etc., can be purchased from Martin Engineering. These accessories are packaged in kits for convenience and are ordered separately from the Air Cannon Assembly. Contact Martin Engineering or a representative to determine which kits are required for your specific application.

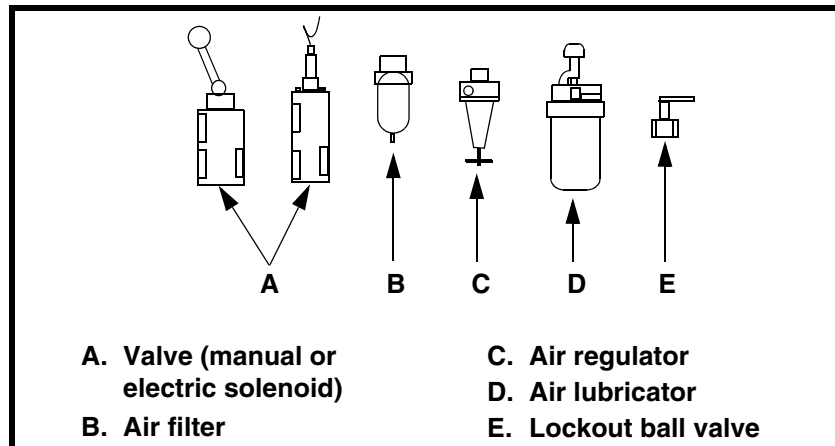

**Figure 4. Air Cannon Accessories**

## ***Specifications***

See Appendix A for technical data specific to individual models.

## ***References***

The following documents are referenced in this manual:

- American National Standards Institute (ANSI) z244.1-1982, *American National Standard for Personnel Protection - Lockout/Tagout of Energy Sources - Minimum Safety Requirements*, American National Standards Institute, Inc., 1430 Broadway, New York, NY 10018.
- Federal Register, Volume 54, Number 169, Part IV, 29 CFR Part 1910, *Control of Hazardous Energy Source (Lockout/Tagout); Final Rule*, Department of Labor, Occupational Safety and Health Administration (OSHA), 32nd Floor, Room 3244, 230 South Dearborn Street, Chicago, IL 60604.
- *The National Electrical Code (NEC) Handbook*, National Fire Protection Association, 1 Batterymarch Park, P.O. Box 9101, Quincy MA 02269-9101.
- ICS 1-1988, *General Standards for Industrial Control and Systems*, and 250-1985, *Enclosures for Electrical Equipment (1000 Volts Maximum)*, National Electrical Manufacturers Association (NEMA), 2101 L Street N.W., Washington, D.C. 20037.
- *Section VIII, Rules for Construction of Pressure Vessels, Division 1*, American Society of Mechanical Engineers, United Engineering Center, 345 East 47th Street, New York, NY 10017.

## ***Safety***

All safety rules defined in the above documents, and all owner/employer safety rules, must be strictly followed when installing and servicing this equipment.

## ***Materials required***

Materials other than standard hand tools that are required to complete tasks are listed where applicable.

## Before Installing Air Cannon

---

### **IMPORTANT**

**The delivery service is responsible for damage occurring in transit. Martin Engineering CANNOT enter claims for damages. Contact your transportation agent for more information.**

1. Inspect shipping container for damage. Report damage to delivery service immediately and fill out delivery service's claim form. Keep any damaged goods subject to examination.
2. Remove air cannon assembly from shipping container. A pressure relief valve, safety restraining cable, and warning labels will be included in this container.
3. If you purchased accessories from Martin Engineering, they will be packaged separately. Remove this equipment from its shipping container.
4. Take inventory of the equipment received. If anything is missing, contact Martin Engineering or representative.

### **⚠ WARNING**

**Before installing air cannon, lock out/tag out any equipment that is loading or unloading material from the storage vessel.**

5. Turn off and lock out/tag out energy source to accessory equipment according to ANSI standards (see "References").

### **⚠ WARNING**

**If equipment will be installed in an enclosed area, test gas level or dust content before using a cutting torch or welding. Using a cutting torch or welding in an area with gas or dust may cause an explosion.**

6. If using a cutting torch or welding, test atmosphere for gas level or dust content.

### **⚠ CAUTION**

**When blasting into closed storage vessel, exhaust vents must be considered to prevent internal vessel air pressure from increasing to point where it may damage vessel.**

7. When blasting into a closed storage vessel, exhaust vents must be considered to prevent internal vessel air pressure from increasing to the point where it may damage the vessel. See Appendix A to determine the volume of air that will be introduced into the vessel with each air cannon blast. Observe local and state codes, which may specify internal pressure limits for your vessel.



**IMPORTANT**

Air cannon force output can vary depending on inlet pressure, discharge opening size, structure size, material in structure, and other factors. To determine maximum force output values for your application, call Martin Engineering.

- 8. If you need to know air cannon maximum force output for your application, call Martin Engineering.

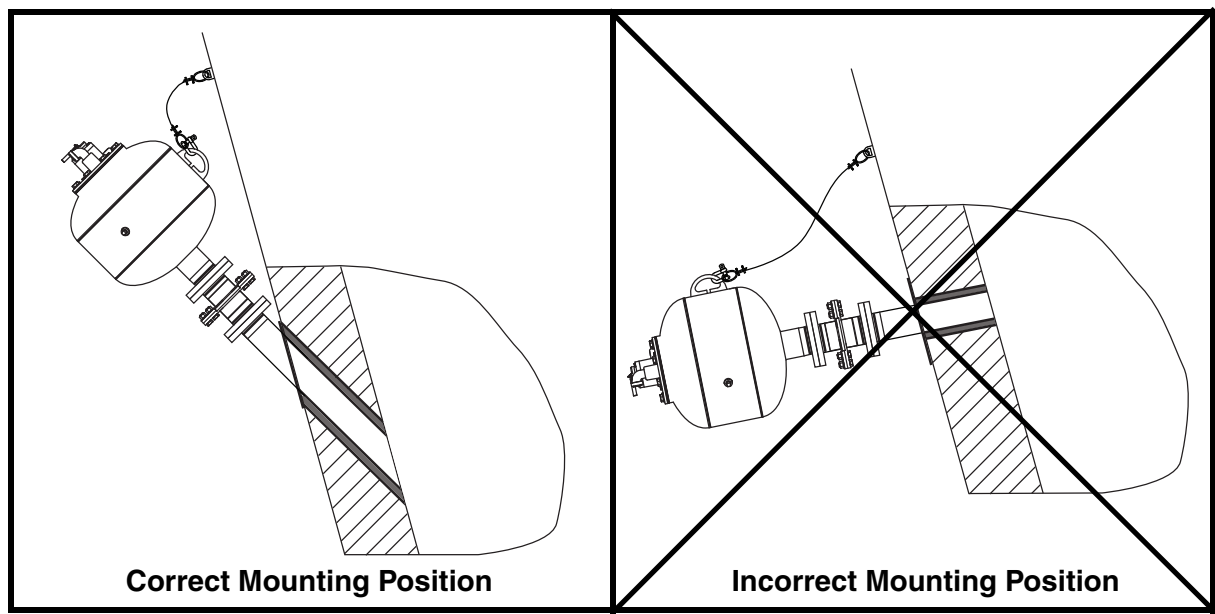

Figure 5. Air Cannon Mounting Orientation

**IMPORTANT**

Do not mount air cannon at a negative angle, see Figure 5. Dirt and dust can collect in air cannon causing rapid wear of air cannon's internal components.

**IMPORTANT**

Air cannons operated in extremely dirty and dusty environments must be lubricated to prevent premature wear of air cannon's internal components. Lubricate air cannon with Martin® Air Motor Oil, p/n 14766.

# Installing Air Cannon

## IMPORTANT

Read entire section before beginning work.

To install air cannon, follow the procedures in this section corresponding to the following steps:

1. Install mounting plate.
2. Connect air cannon to mounting plate.
3. Install restraining cable.
4. Connect air supply to air cannon. See “electrical solenoid valves” as applicable.

A variety of mount plate and nozzle designs are available from Martin Engineering. This section will describe the installation of the most commonly used mount plates and nozzles. The correct mount plate or nozzle must be used for the given application. If you are not sure which mount plate or nozzle to use for your application, contact Martin Engineering or representative.

## NOTE

**NOTICE OF LIMITED LIABILITY:** Due to possible presence of latent structural defects in the apparatus of the purchaser, Martin Engineering shall not be responsible for consequential damage to the purchaser’s equipment and/or apparatus resulting from the application of a Martin® Product. Martin Engineering shall not be liable for improper installation by the purchaser or other circumstances beyond the control of Martin Engineering. Liability is disclaimed for the structural soundness of apparatus or equipment not supplied by Martin Engineering. Liability shall be strictly limited to the replacement of the purchased product or refund of the purchase price. To secure the integrity of the installation, specify supervision by qualified personnel from Martin Engineering.

### *Installing mounting plate*

Materials required: Mounting plate or seal plate and support structure.

Material and field welds: If mild steel to mild steel use a 7018 or equivalent rod. If stainless steel to stainless steel, use 308 or equivalent welding rod. If stainless steel to mild steel, use 309 or equivalent welding rod.

## NOTE

**If you are unsure where to locate air cannon(s) on your storage vessel, contact Martin Engineering or your representative.**

1. Mark location for each air cannon on storage vessel.

2. A standard carbon steel mount plate or nozzle can be used for internal vessel temperatures of less than 500°F.
  - a. If using 30-degree mounting plate (Figure 6), cut hole in storage vessel for each mounting plate using templates on last page of this manual. If templates are missing, contact Martin Engineering or representative. Place mounting plate over hole and field weld to vessel skin.

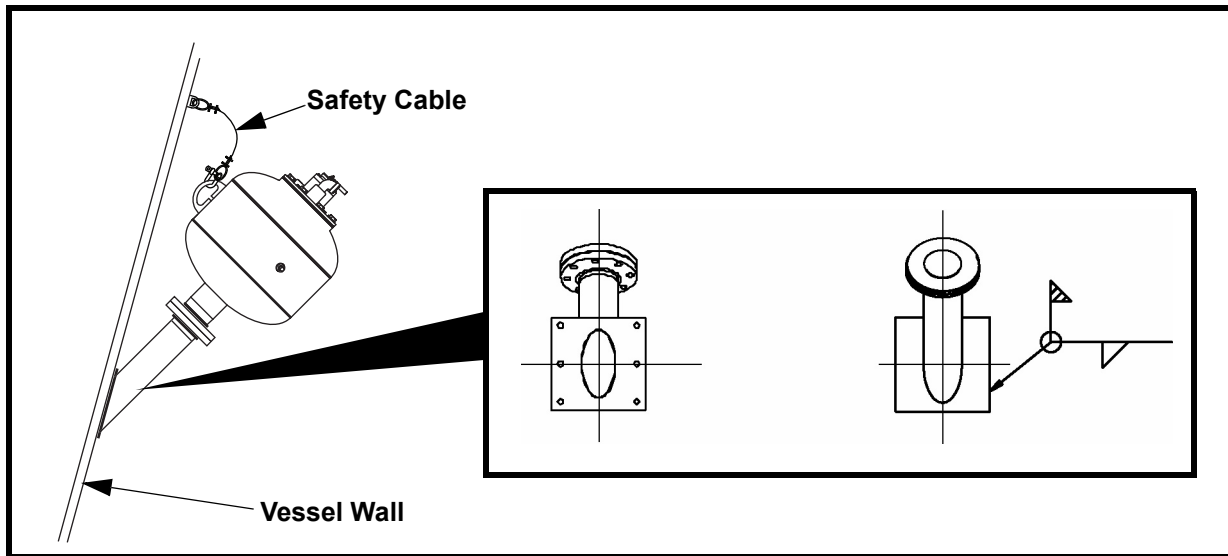

**Figure 6. Installing 30-Degree Mounting Plate**

- b. If mount plate is to be welded to vessel, bolt holes must be cut away or plug-welded in order to prevent air leakage upon discharge. If mount plate is to be bolted to vessel, gasket must be used to prevent air leakage upon discharge.
- c. If vessel has a liner (Figure 7), drop-through blow-pipe must be used. The blow pipe must be extended past liner so that liner is not damaged from air cannon blast.

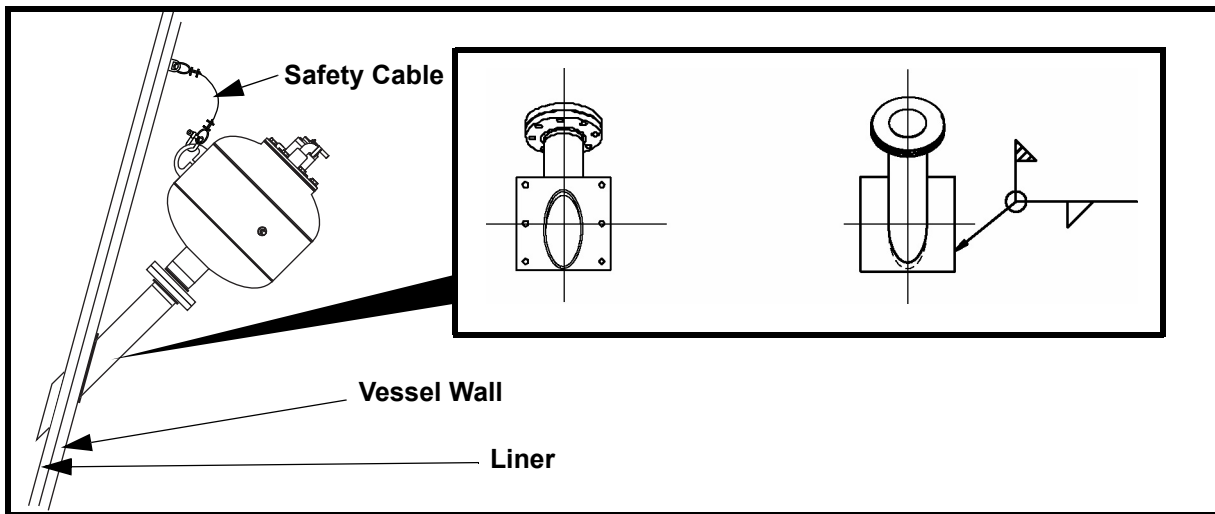

**Figure 7. Installing a Drop-Through 30-Degree Mounting Plate for Vessels with Liner**

d. Martin® SMART™ Series Nozzles and blow pipes (Fig. 8) should be used in applications where the internal vessel temperature exceeds 500°F.

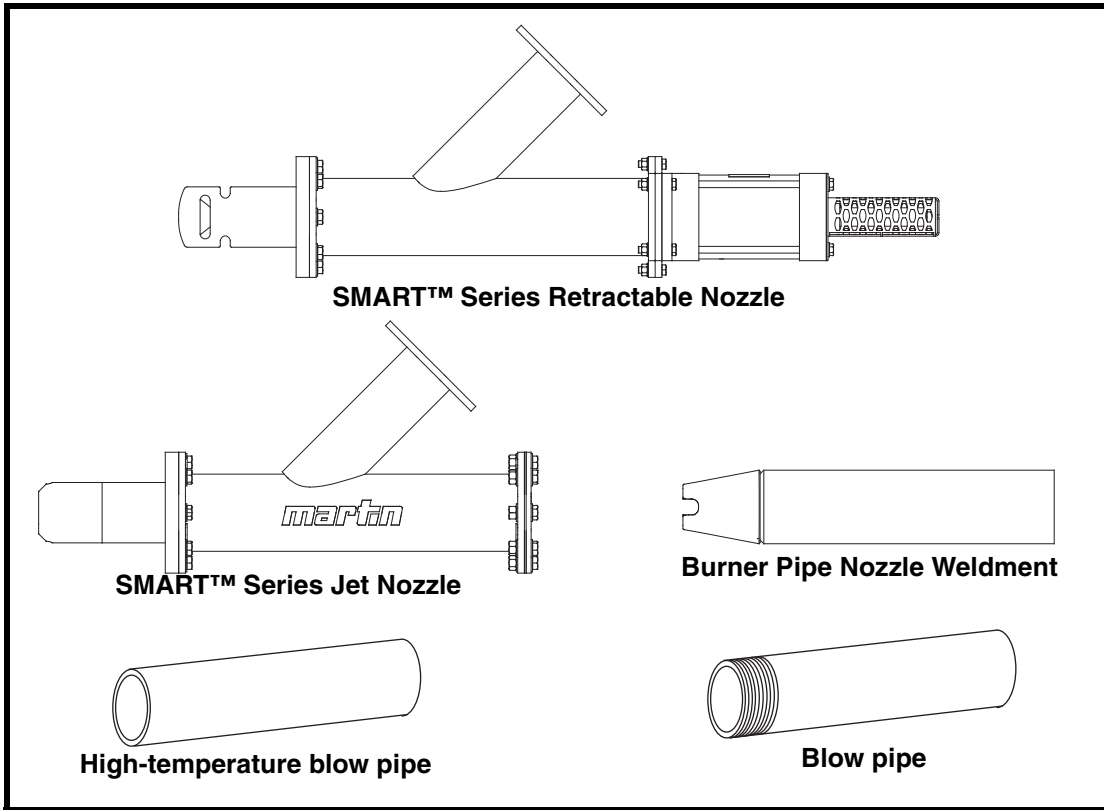
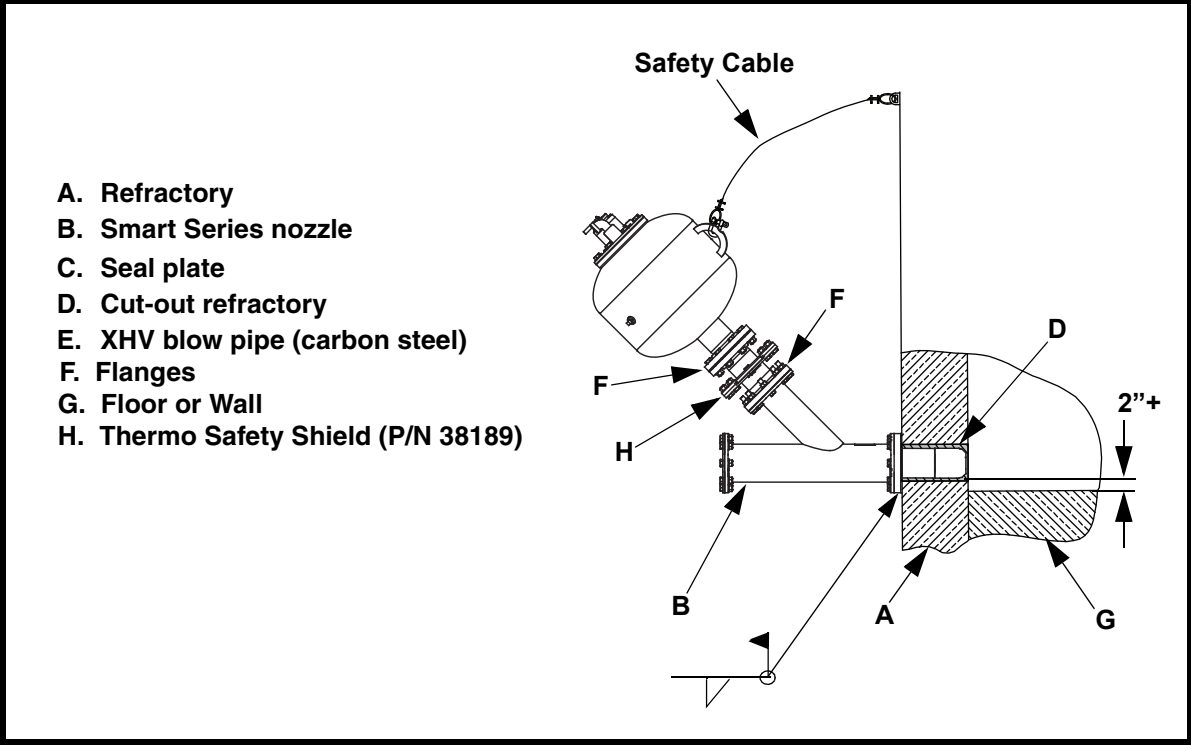
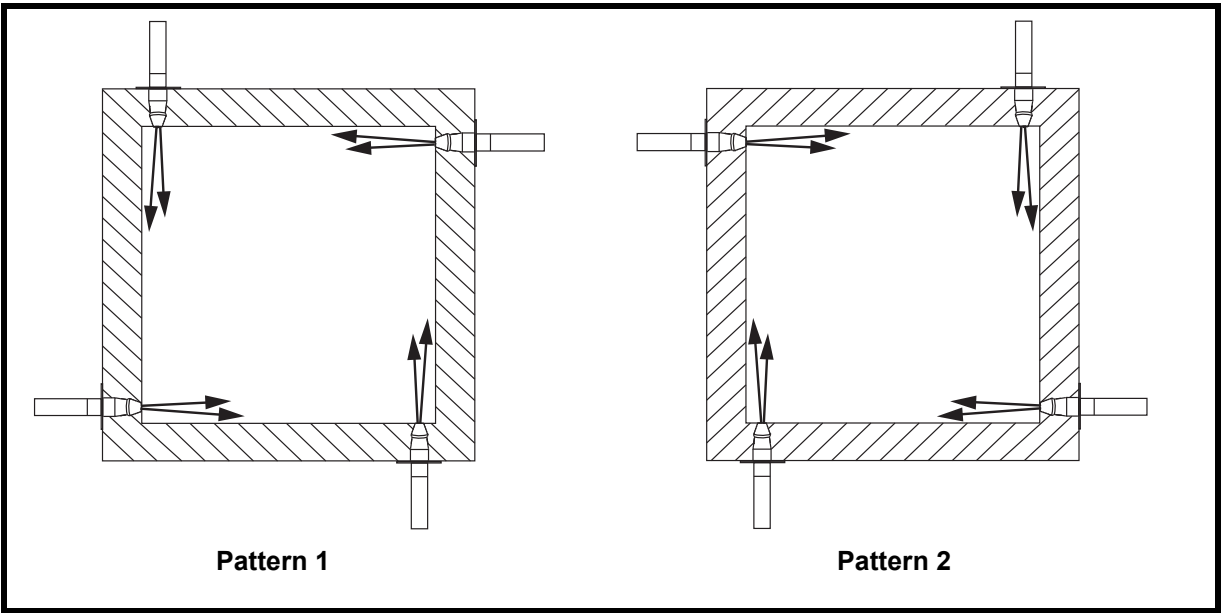

Figure 8. Mounting Nozzles/Pipes for High-Temperature Applications

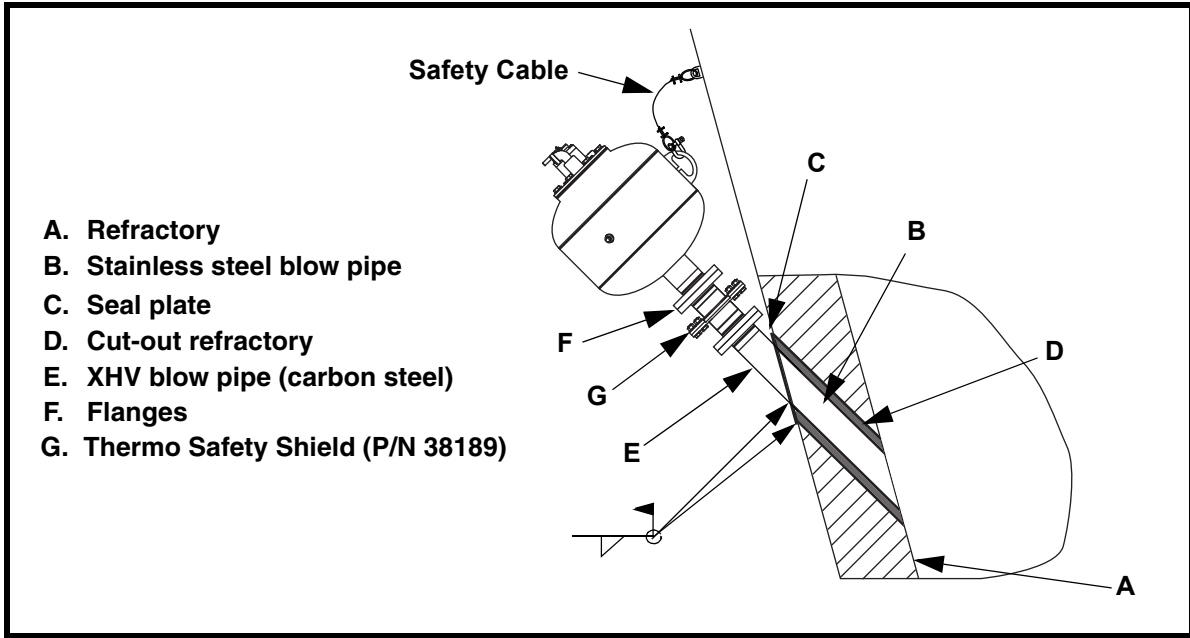

**Figure 9. Installing Martin<sup>®</sup> SMART<sup>™</sup> Series Jet Nozzle for High-Temperature Applications**

3. Plan view of nozzle placement for riser duct application. Alternate levels between Pattern 1 and Pattern 2 for maximum area coverage.



**Figure 10. Riser Duct with Fan Nozzles for High-Temperature Applications**



**Figure 11. Installing Stainless Steel Blow Pipe and Carbon Steel Blow Pipe for High-Temperature Applications**

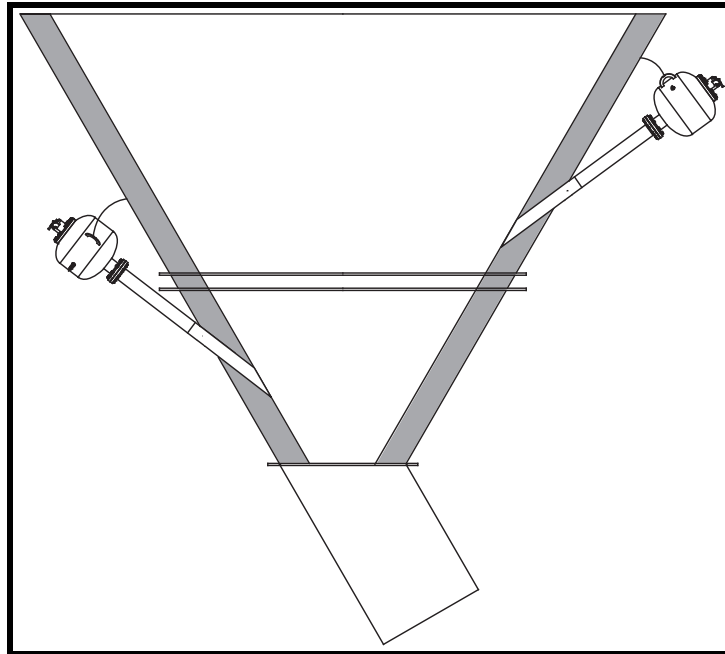

**Figure 12. Cyclone with High-Temperature Blow Pipes**

***Connecting air cannon to mounting plate***

1. One flange will be connected to blow pipe and other will be connected to air cannon's discharge flange weldment.
  - a. For threaded end pipe, screw pipe flange onto pipe completely. If necessary, tack weld connection to prevent from becoming loose. DO NOT weld threaded connection completely.
  - b. For plain end pipe, place slip-on flange over end of pipe and fillet weld completely.

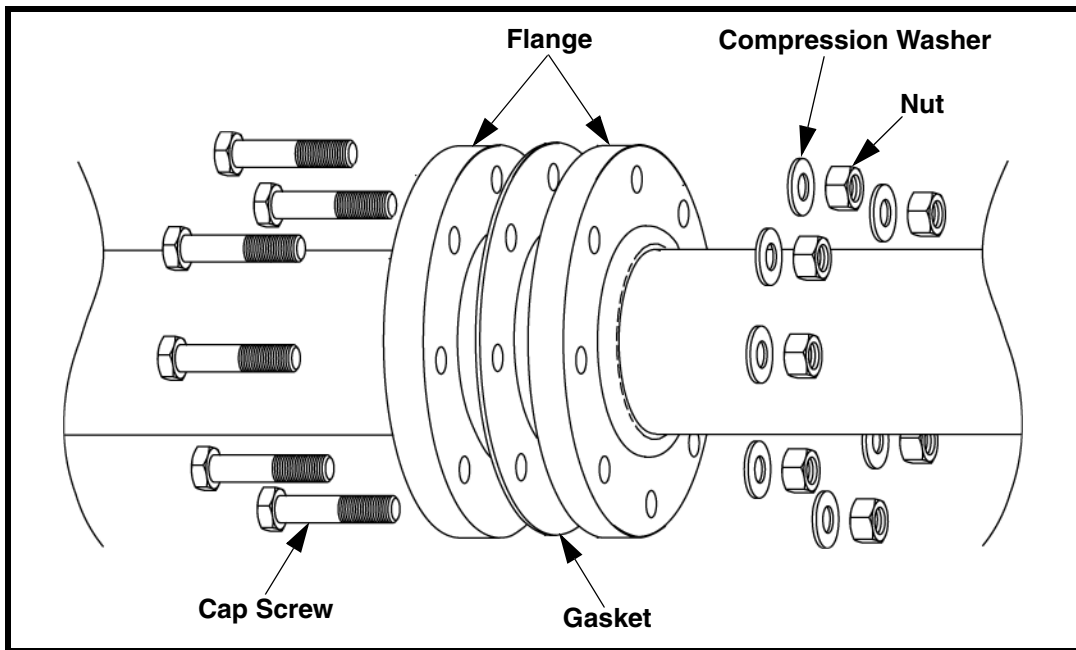

**Figure 13. Flange Installation**

2. Place a gasket between the flanges and assemble using cap screws, nuts and compression washers.

***Installing restraining cable***

**⚠ WARNING**

Always install restraining cable to secure air cannon to storage vessel. Without restraining cable, air cannon could fall and cause injury.

Do not use restraining cable to mount air cannon to storage vessel wall. Purpose of restraining cable is to keep air cannon from falling should it come loose from vessel wall, not as primary means of securing air cannon to wall.

**⚠ CAUTION**

Do not use angle iron or support ring to secure air cannon rigidly to storage vessel. If restrained too rigidly, tank cannot flex and air cannon can fail.

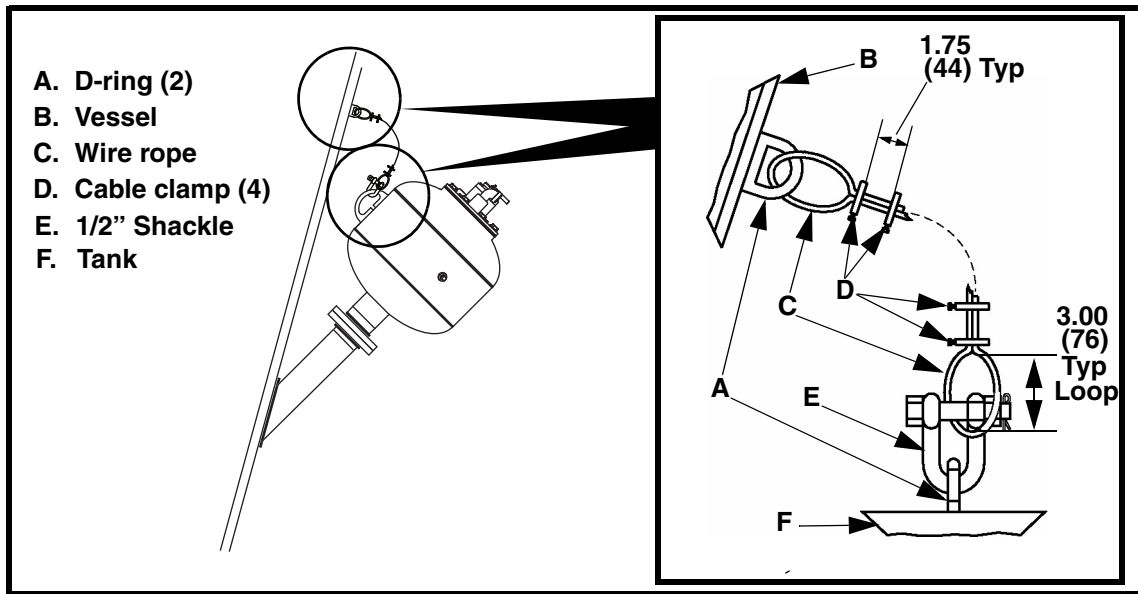

**Figure 14. Installing Restraining Cable**

1. Weld D-ring (A, Figure 14) onto storage vessel (B) with 1/4-in. (6-mm) field weld.
2. Insert wire rope (C) through D-ring on storage vessel, making a 3-in. (76-mm) loop. If wire rope supplied with air cannon is not long enough, loop and clamp it to an additional cable and attach additional cable to air cannon.
3. Clamp wire rope with one cable clamp (D) as close to loop as possible. Place another cable clamp 1-3/4 in. (44 mm) from first clamp.
4. Leave at least 1 in. (25 mm) of wire rope on dead end.
5. Gradually tighten nuts alternately and evenly to 15 ft-lbs. Leave 2 to 3 in. (51 to 76 mm) slack in wire rope.
6. Use the U-bolt to connect the restraining cable to one of the D-rings on tank. Tighten U-bolt's pin with a wrench and insert cotter pin through the hole. Separate ends of cotter pin to ensure U-bolt's pin cannot back out.

### *Connecting air supply to air cannon*

## **IMPORTANT**

Read entire section before beginning work.

## **CAUTION**

When pressure in storage vessel is 4 psi (0.28 bar) or more, apply equal or greater pressure to the air cannon inlet. Absence of inlet pressure will allow material in storage vessel to enter the air cannon and contaminate the valve body and tank.



**IMPORTANT**

To prevent leaking, apply pipe sealant to all fittings. Air cannon will not pressurize if leaks are present.

1. Apply pipe sealant to all fittings.

**⚠ WARNING**

MSHA/OSHA requires the use of an ASME-approved relief valve and an air pressure gauge (see “References”).

2. Remove temporary ½” NPT dust cap from tank inspection port(s) and install pressure relief valve and air pressure gauge. For convenience, the pressure relief valve and air pressure gauge can be installed in the same port using the ½” tee provided with the plumbing kit or air pressure gauge kit. Make sure all ports are tightly plugged.
3. Remove recessed hex-head screw from the valve’s fill port. See Figure 15, 16 or 17.

**⚠ WARNING**

Make sure exhaust ports on valve elbows are pointed downward so that dirt cannot enter and exhaust is not directed at personnel. Do not plug or reduce the diameter of the exhaust ports.

**IMPORTANT**

Electric solenoid valves distributed by Martin Engineering are recommended. Substitute valves may not work as effectively.

**NOTE**

Additional control valves such as: manually-actuated valves, explosion-proof valves, and box-enclosed manifolds are also available from Martin Engineering. Contact your local representative for detailed information if you are installing one of these options. Solenoid ports are (1) inlet, (2) outlet, and (3) exhaust.

4. Connect the 3-way electric solenoid valve.
  - a. If using a normally-opened solenoid valve, connect the 3-way electric solenoid valve outlet port (2) to exhaust valve fill port. See Figure 15.
  - b. If using a normally-closed solenoid valve, connect the 3-way electric solenoid valve outlet port (2) to exhaust valve control port. See Figure 16.
5. Connect air filter/regulator to the 3-way electrical solenoid valve inlet port with desired length of ½” pipe. Look at arrow on side of filter/regulator to make sure flow is correct.

**IMPORTANT**

OSHA/MSHA requires installation of a lockout ball valve (see “References”).

6. Connect lockout ball valve to air filter/regulator with desired length of ½” pipe. Look at arrow on side of ball valve to make sure flow is correct.
7. Connect lockout ball valve to compressed air source with desired length of ½” pipe. Additional lockout ball valves can be placed in fill and control lines as desired.

**IMPORTANT**

For electrical solenoid valve installations, design and wire electrical solenoid controls according to NEC Handbook. Electrical push buttons, timers, and programmable controllers are available through Martin Engineering.

8. For electrical solenoid valve installations, if using electrical solenoid controller, install according to instructions provided with controller.

**⚠ WARNING**

Do not exceed 125 psi (8.62 bar) maximum working pressure or the pressure relief valve will open. Minimum recommended pressure for most applications is 80 psi (5.52 bar), but lower pressures can be used. Make sure air supply is filtered and regulated.

The pressure relief valve may relieve at any point between 90% and 100% of set pressure. Exceeding the MAWP of the tank can cause it to rupture.

**NOTE**

Pressure relief valves of up to 150 psi are available from Martin Engineering. Consult the Maximum Allowable Working Pressure (MAWP) on the tank's name plate before substituting a different pressure relief valve. Never use a pressure relief valve with a set pressure that is higher than the MAWP of the tank.

9. Anchor all pipes and wires to prohibit movement.

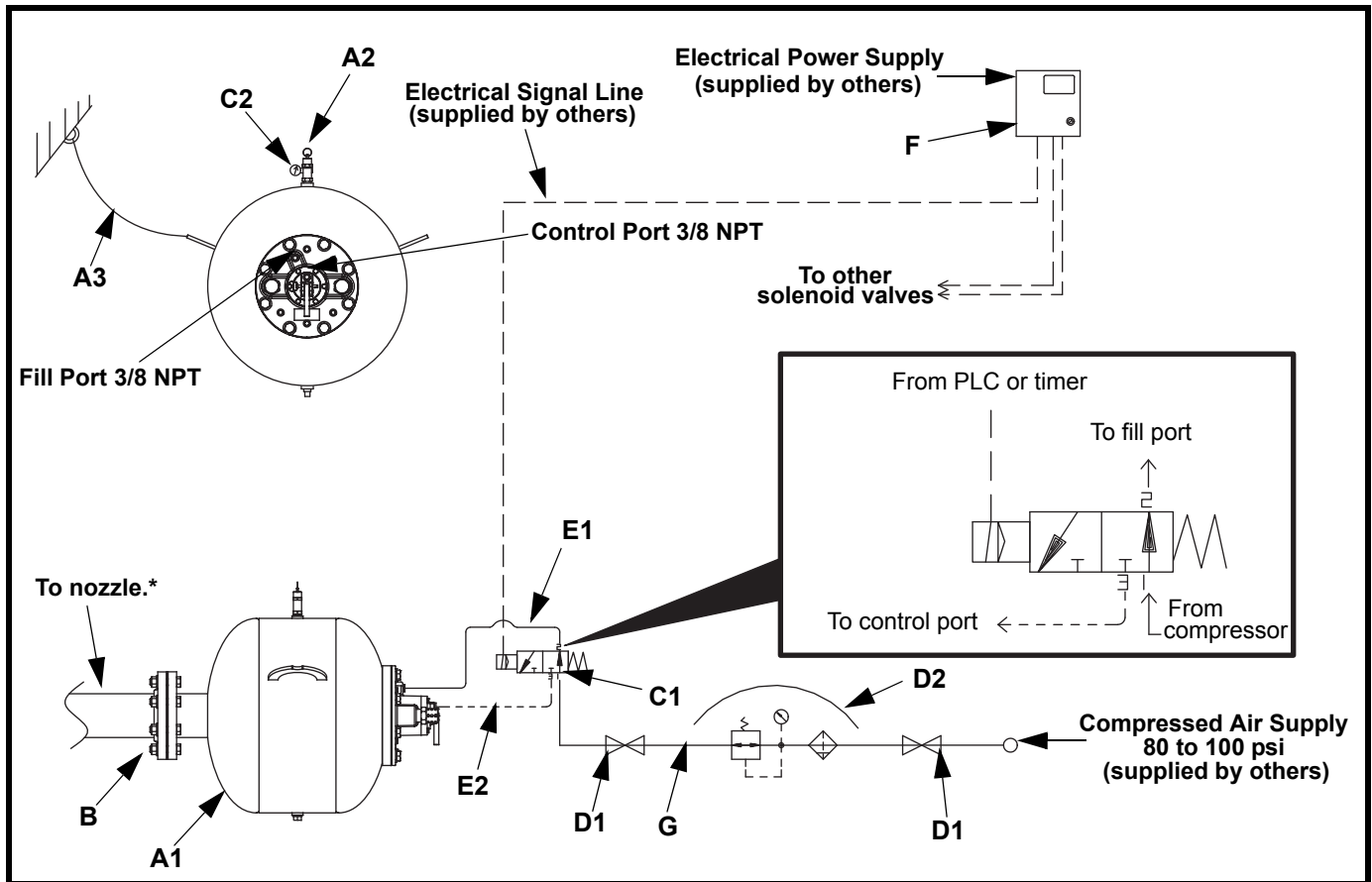

**Figure 15. Plumbing Detail for Normally-Opened Solenoid Valve**

Item	Description	Assembly and Kit Part Numbers**
A1	Air Cannon	38005-35, 38005-70, or 38005-150
A2	Safety Relief Valve	
A3	Safety Cable	
B	NPT Flange Assembly	25698-1
C1	3-Way 2-Position Solenoid Valve (normally opened)	37885-110
C2	Air Pressure Gauge	
D1	Lockout Valve	See Figure 22
D2	Filter Regulator Unit	
E1	Air Fill Hose	37892
E2	Air Control Hose	
F	Controller/PLC	*
G	Air Supply Pipe	supplied by others

\* Contact MARTIN ENGINEERING for recommendation.

\*\* Contact MARTIN ENGINEERING for breakdown of parts contained in assemblies and kits.

# Installation

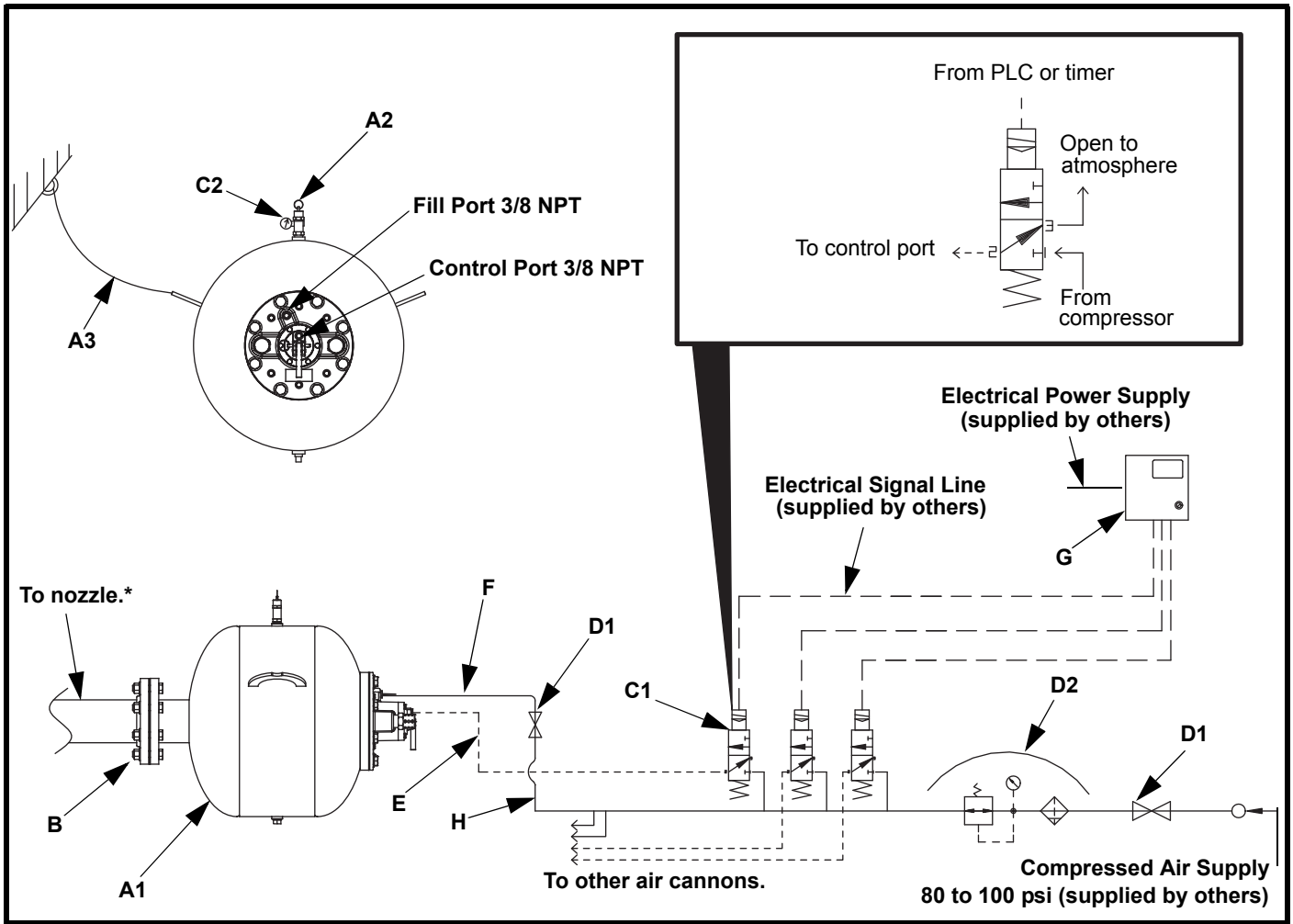
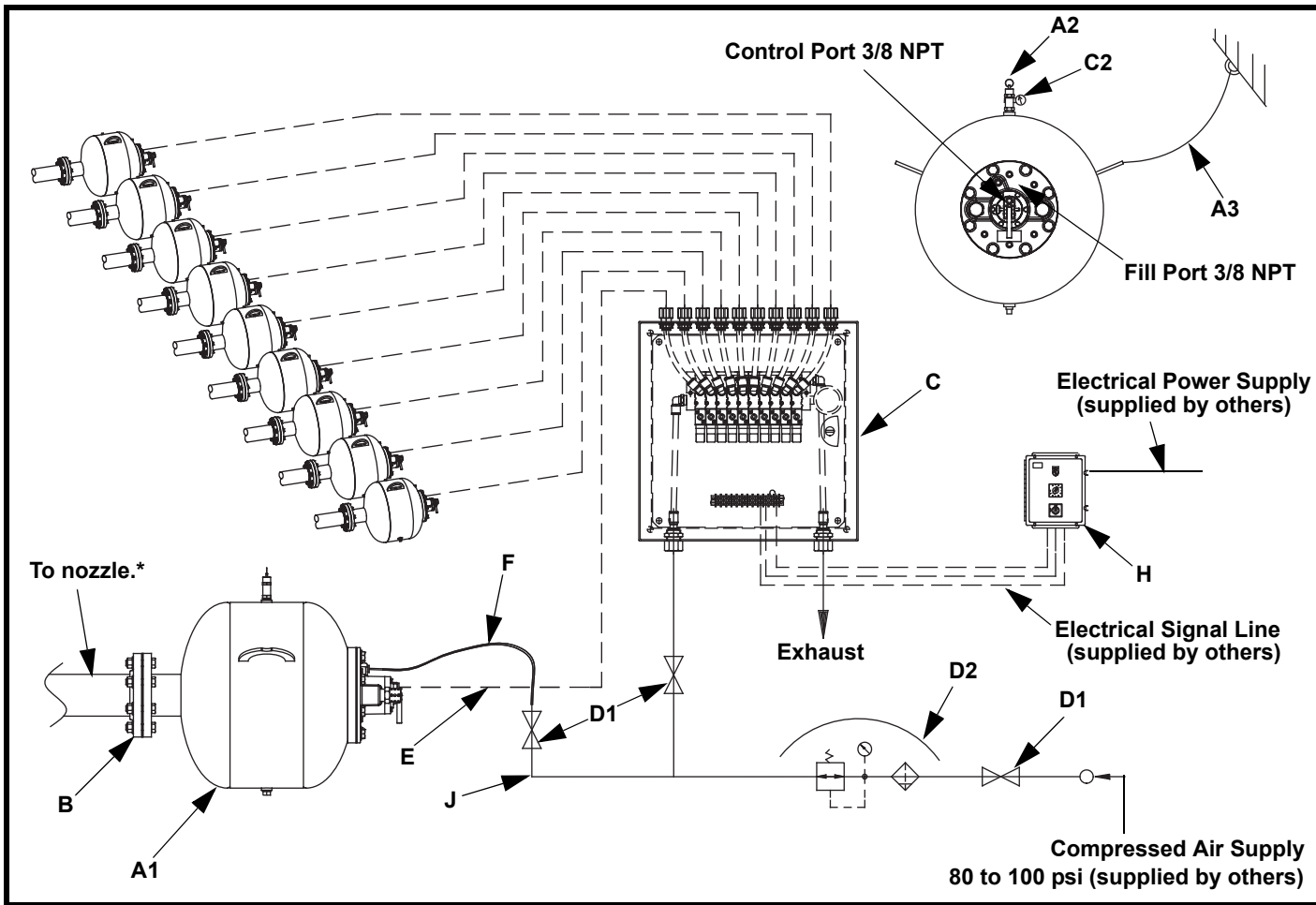

**Figure 16. Plumbing Detail for Normally-Closed Solenoid Valve**

Item	Description	Assembly & Kit Part Numbers**
A1	Air Cannon	38005-35, 38005-70, or 38005-150
A2	Safety Relief Valve	
A3	Safety Cable	
B	NPT Flange Assembly	25698-1
C1	3-Way 2-Position Solenoid Valve (normally closed)	37886-110
C2	Air Pressure Gauge	
D1	Lockout Valve	See Figure 22
D2	Filter Regulator Unit	
E	Air Control Hose	33739
F	Air Fill Hose	37452
G	Controller/PLC	*
H	Air Supply Pipe	supplied by others

\* Contact MARTIN ENGINEERING for Recommendation.

\*\* Contact MARTIN ENGINEERING for breakdown of parts contained in assemblies and kits.



**Figure 17. Plumbing Detail for Ten Bank Solenoid Cabinet**

Item	Description	Assembly & Kit Part Numbers**
A1	Air Cannon	38005-35, 38005-70, or 38005-150
A2	Safety Relief Valve	
A3	Safety Cable	
B	NPT Flange Assembly	25698-1
C	Solenoid Enclosure 10 Bank	37994-10
D1	Lockout Valve	See Figure 22
D2	Filter Regulator Unit	
E	Air Control Hose	33739
F	Air Fill Hose	37452
G	Kit Air Gauge	34843
H	Air Cannon Controller	38901
J	Air Supply Pipe	supplied by others

\* Contact MARTIN ENGINEERING for Recommendation.

\*\* Contact MARTIN ENGINEERING for breakdown of parts contained in assemblies and kits.

## After Installing Air Cannon

---

### IMPORTANT

Read entire section before beginning work.

1. Thoroughly wipe storage vessel wall clean next to vessel door/port. Place Air Blast Warning Label, P/N 31913, on vessel wall visible to anyone opening door/port. If more than one door or port exists on storage vessel, request additional labels from Martin Engineering or representative. Attach Lockout Valve Warning Tag, P/N 35146, to lockout valve with cable tie (supplied).
2. Purge air lines.

### IMPORTANT

Charge each air cannon individually during initial start-up to avoid significant pressure loss.

Relief valve is preset to open at 125 psi (8.62 bar).

### ⚠ WARNING

Do not exceed 125 psi (8.62 bar) maximum working pressure or pressure relief valve will open. Minimum recommended pressure for most applications is 80 psi (5.52 bar) but lower pressures can be used. Make sure air supply is filtered and regulated.

### NOTE

Pressure relief valves of up to 150 psi are available from Martin Engineering. Consult the Maximum Allowable Working Pressure (MAWP) on tank's name plate before substituting a different pressure relief valve. Never use a pressure relief valve with a set pressure that is higher than the MAWP of the tank.

### ⚠ WARNING

Pressure relief valve may relieve at any point between 90% and 100% of set pressure. Exceeding MAWP can cause tank to rupture.

3. Supply 80 to 125 psi (5.52 to 8.62 bar) filtered and regulated air to system.
4. If air cannon does not charge, see “Troubleshooting.”
5. Check system for air leaks. If leaking, see “Troubleshooting.”

**NOTE**

When air cannon blasts, a small amount of air will release from solenoid valve and quick exhaust valve.

**⚠ DANGER**

Do not open door/port or enter storage vessel when cannons are charged and operational. Flying debris from cannons' blast can kill you.

If air cannons are installed on open pit or on structure with no top, make sure area is clear before firing cannons. Flying debris from cannons' blast can kill you.

**⚠ WARNING**

Air cannons are loud when firing. Use ear protection to avoid impairment or loss of hearing.

6. Blast air cannon as follows: for air cannons with electrical solenoid valves and external electrical controls, activate electrical solenoid valve by external control (electrical push button, timer, etc.) or by pushing button on electrical solenoid valve. (If wired correctly, this should send signal to solenoid valve closing inlet to outlet and opening outlet to exhaust.)
7. Blast air cannon five times to ensure proper operation. Allow tank to fill after each blast.
8. If air cannon blasts properly, continue to operate air cannon as needed. If problems occur, see "Troubleshooting."
9. Keep air cannon charged with air at all times so unit is always ready for use and so material cannot flow into air cannon.

# Maintenance

---

**IMPORTANT**

Read entire section before beginning work.

**▲ WARNING**

**Turn off and lock out/tag out air supply and energy source before blasting air cannon to prevent air cannon from refilling.**

**▲ WARNING**

**Do not open door/port or enter storage vessel before turning off compressed air source, locking out controls, purging line pressure, and venting air completely from tank.**

Turn off and lock out/tag out energy source according to ANSI standards (see “References”).

## *Monthly inspection*

1. Inspect all connections from air supply to tank for leaks and deterioration. If connections are leaking, seal all fittings with pipe sealant and tighten. Replace any deteriorating connections. Make sure hoses do not flex more than 1/4 inch (6 mm).
2. Make sure all pipes and wires are anchored to prohibit movement. Secure as needed.
3. Inspect valve assembly, electrical solenoid valve, lockout ball valve, and air filter/regulator for proper operation. If not operating correctly, replace.
4. Inspect air gauge for correct operation; make sure lens is clean and visible.
5. Inspect safety relief valve: pull ring to bleed off a small amount of compressed air and make sure diaphragm closes back to an air-tight seal.
6. Inspect safety cable (restraining cable); make sure clamp connections are secure and there is no excessive corrosion or frayed cable.
7. Wipe all warning labels clean. If labels are not readable, contact Martin Engineering or representative for replacements.



## ***Periodic maintenance***

1. Blast air cannon to remove air from tank, then pull ring on relief valve to make sure air stored in cannon has been released.
2. Perform monthly maintenance. See “Monthly inspection.”
3. After all air is released, remove drain plug. Allow all moisture to drain from tank.
4. After all moisture is removed, apply pipe sealant to drain plug. Install drain plug on tank.

### **⚠ CAUTION**

**Do not weld tank. Paint in tank will melt and welding will violate ASME code. If tank is damaged or leaking, do not use air cannon until tank is replaced or repaired by Martin Engineering.**

5. Inspect air cannon mounting area for rust and loose screws, welds, and bolts. Replace, tighten, or weld as necessary.
6. Inspect tank, valve body, piston, and discharge nozzle for damage. Replace or return to Martin Engineering for repair as necessary.
7. Inspect restraining cable for wear. Replace if worn.
8. On units with electrical controls, inspect wires and connections. Repair or replace wires to NEC Handbook standards as necessary.

### **⚠ WARNING**

**Turn off and lock out/tag out air supply and energy source before blasting air cannon to prevent air cannon from refilling. Failure to do so could result in injury to personnel and damage to equipment.**

**Do not open door/port or enter storage vessel before turning off compressed air source, locking out controls, purging line pressure, and venting air from tank.**

### **⚠ DANGER**

**Shutting off lockout ball valve will purge all cannons connected to that valve and cause the air cannons to fire immediately. Do not shut off the valve until you make sure no one is in the structure or near its discharge. Flying debris from the cannons’ blast can kill you.**

## ***Air Cannon Valve Assembly Replacement***



1. De-energize the air cannon; completely drain all compressed air energy from tank.
2. Close safety slide gate if equipped with one. If your air cannon has an open discharge port, make sure you are safely isolated from free-flowing material or hazards inside the discharge area.

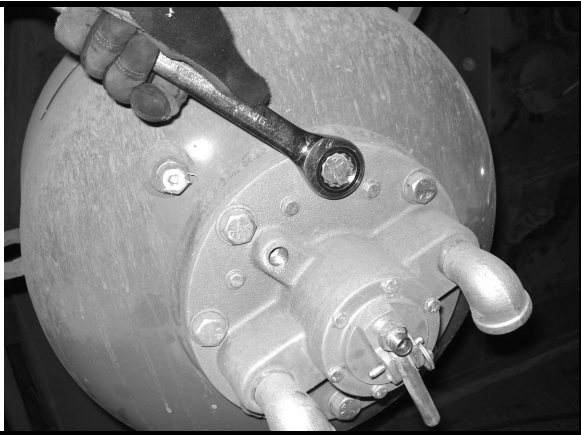
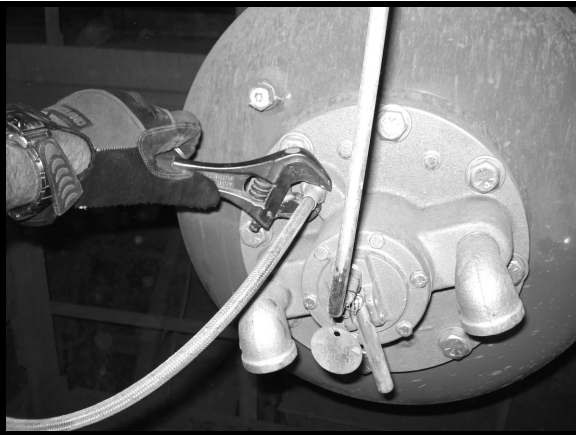

3. Disconnect air lines.
4. Remove the 8 bolts on the valve assembly.

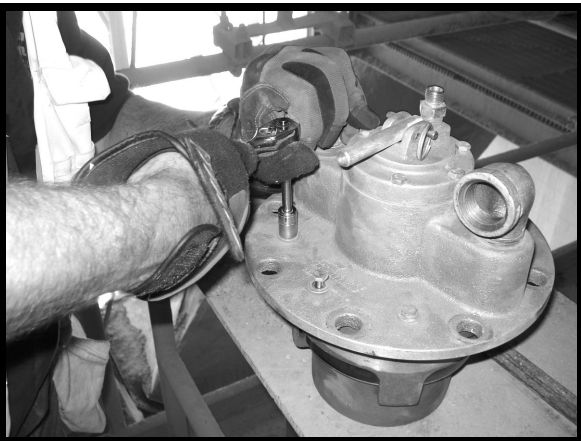
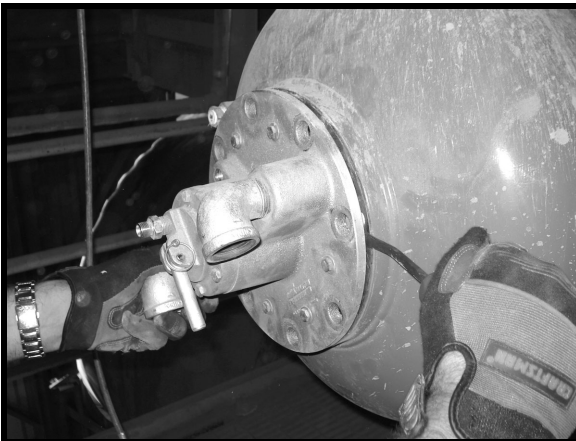

5. Remove valve from tank. A small pry bar can help if O-rings are dry.
6. With the valve assembly removed, the rebuild can be done in the maintenance shop (see list of rebuild kits on page 26).

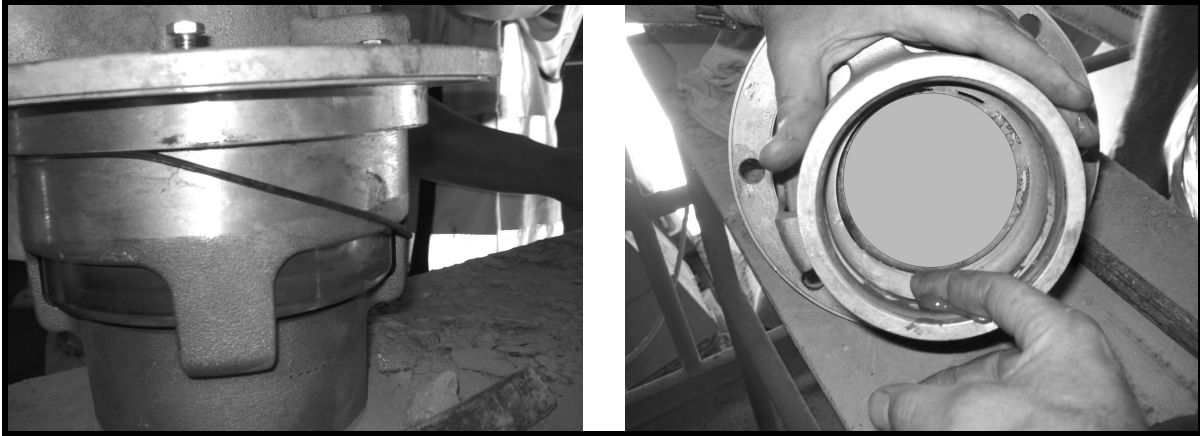

7. When replacing the valve assembly on the tank, a small amount of grease will secure the O-ring. Make sure O-ring stays secure during the reassembly.
8. Place a small amount of grease on the discharge tube O-rings.



9. Inspect interior of air cannon. Make sure discharge tube has a clean and smooth surface for air-tight O-ring seal.
10. Mate the valve assembly back onto discharge tube, making sure not to pinch O-ring.

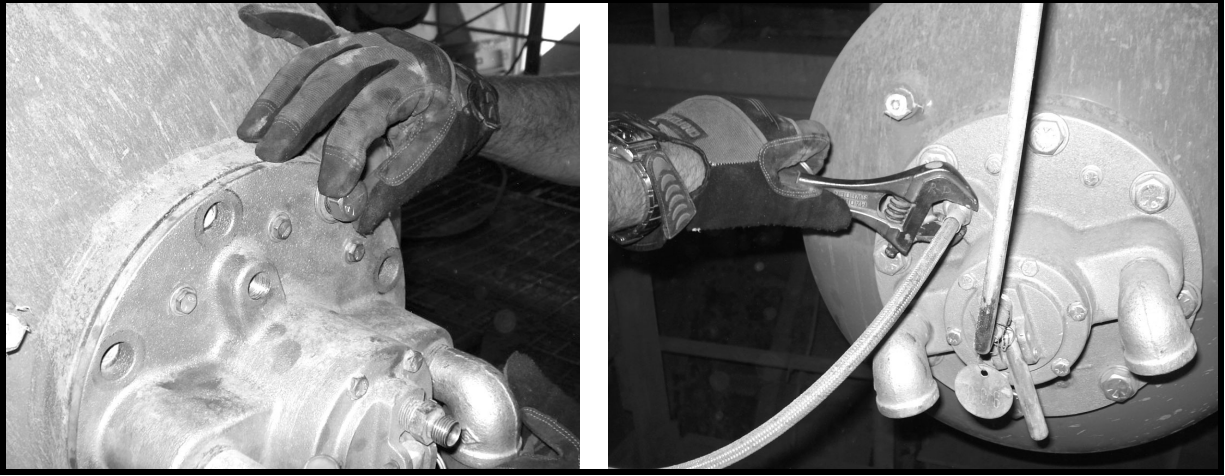

11. Install the 8 cap screws and compression washers.
12. After the valve assembly is bolted to tank, re-connect air lines. Ensure there are no leaks or loose connections.

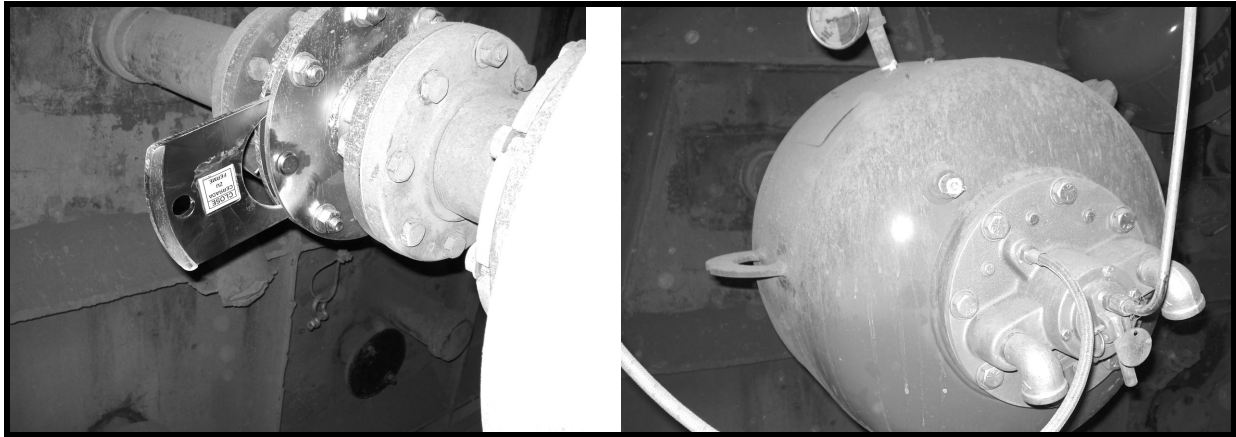

13. If present, pin the Martin<sup>®</sup> Thermo Safety Shield back to open position.
14. Slowly pressurize air cannon. Check for leaks from any pinched O-rings.
15. When air cannon is pressurized and ready for operation, test fire the cannon.
16. The air cannon is now ready for operation.

**NOTE**

Watch air gauge when air cannon is fired. Needle should drop to “zero” instantly. Exhaust ports should be pointing down so that no dirt can fall into exhaust valve.

# Troubleshooting

If air cannon will not charge or discharge, find possible cause(s) in appropriate chart below and follow steps in “Solution” column. If after doing so you are still experiencing problems, contact Martin Engineering or representative.

<b>Problem: Air Cannon Will Not Charge</b>	
<b>Cause</b>	<b>Solution</b>
Compressor source.	Make sure compressor is on and air line has pressure.
Ball valves open.	Check that ball valves are fully open to each cannon.
Filter/Regulator.	Factory-set at zero. Rotate clockwise to increase. Check plumbing air flow direction (indicated with an arrow).
Solenoid plumbing.	Check connections. Port 1 = inlet; Port 2 = outlet; Port 3 = exhaust.
Tank plugs missing.	Check to see whether any NPT ports on tank have been left open.
Fill port connection on air cannon.	Check that air supply is connected to “fill port.”

<b>Problem: Air Cannon Will Not Discharge</b>	
<b>Cause</b>	<b>Solution</b>
Solenoid plumbing.	Make sure plumbing is correct. Check for leaks. Check plumbing direction.
Solenoid electrical.	Make sure wiring is connected. Check that voltage is correct. Check for signal.
Tank pressure.	Check air gauge.
Control line is not correct.	Check that control line is connected correctly to air cannon and solenoid.
Air cannon exhaust ports.	Check street elbows. The [two] 1-inch street elbows CAN NOT be plugged or reduced down.
Blocked discharge—cannon makes “sputtering” sound when discharging; air gauge drops slowly or does not go all the way to zero.	Remove blockage.
Control line has a leak or blockage.	Check that air line is not too long (over 200 ft.).
Operating pressure is low.	Check that operating pressure is at 80–100 psi.
Control signal too short.	Make sure that solenoid stays on long enough for correct operation (1 second).
Air gauge not working correctly.	Be sure that air gauge drops to “0” psi in less than ½ second.

## **Part Numbers**

---

This section provides product names and corresponding part numbers for Martin® Hurricane Air Cannons and related equipment. Please reference part numbers when ordering parts. Part numbers for accessory equipment not listed here are available from Martin Engineering or representative.

### ***Air Cannons***

#### **Martin® Hurricane Air Cannon Assembly:**

**Model 35 L:** P/N 38005-35

**Model 70 L:** P/N 38005-70

**Model 150 L:** P/N 38005-150

### ***Air Cannon Repair Parts***

**Pressure Relief Valve:** P/N 21680

**Air Pressure Gauge:** P/N 34842

**Safety Cable Kit:** P/N 32271

**Martin® Hurricane Air Cannon Valve Assembly:** P/N 38071

**Martin® Hurricane Air Cannon Valve Rebuild Kit:** P/N 38137-4

**Martin® Hurricane Air Cannon Exhaust Valve Cap Replacement Kit:**  
P/N 38136

**Martin® Hurricane Air Cannon Main Piston Rebuild Kit:** P/N 38426

**Martin® Air Motor Oil:** P/N 14766

Contact Martin Engineering for information on other repair parts.

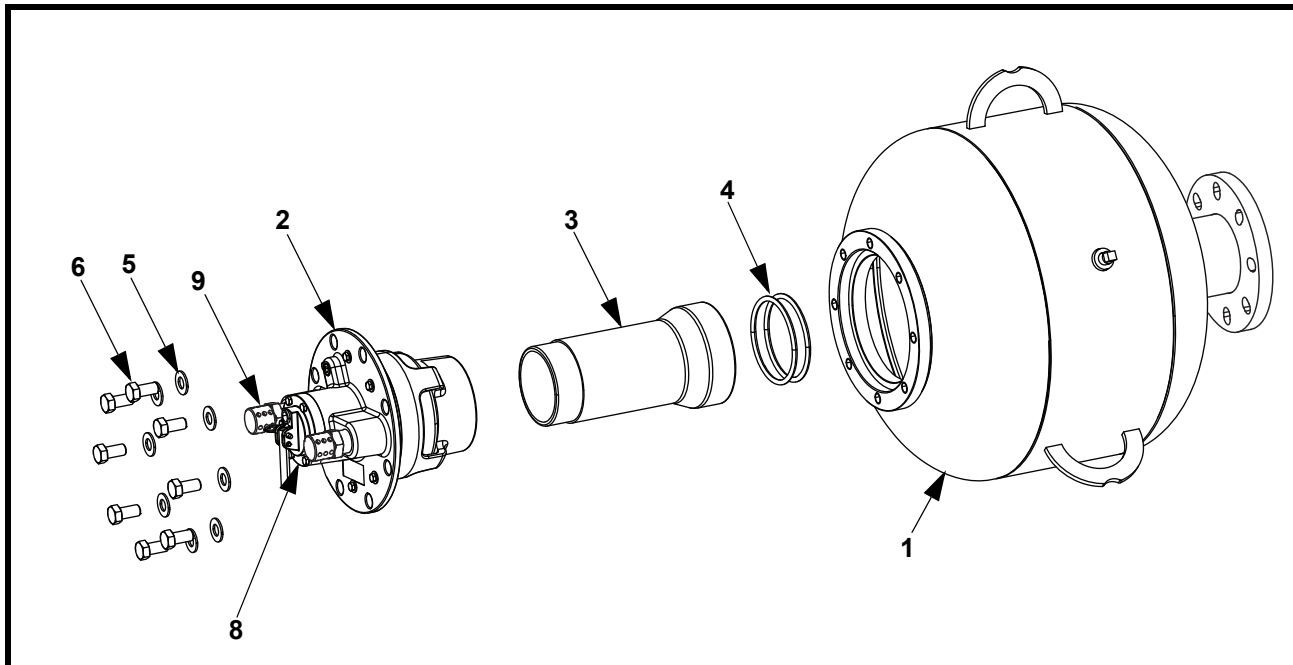

**Figure 18. Martin® Hurricane Air Cannon Assembly Parts List**

Item	Description	Part No.	Qty
1	Tank (35 Liter)	38181-35	1
	Tank (70 Liter)	38181-70	
	Tank (150 Liter)	38181-150	
2	Valve Assembly	38071	1
3	Aluminum Pipe Coupling	38602	1
4	O-ring #425, 4.50 ID x .275 CS	20771-S	2
5	Washer Compression 5/8	11752	8
6	Screw, HHC 5/8-11NC x 1-1/4 ZP	15798	8
7 (NS)	Valve Safety 1/2 NPT Brass	21680	1
8	Exhaust Valve Cap Assembly	38136	1
9	Diffuser	39468	2
10 (NS)	Safety Cable Kit	32271	1

NS = Not Shown

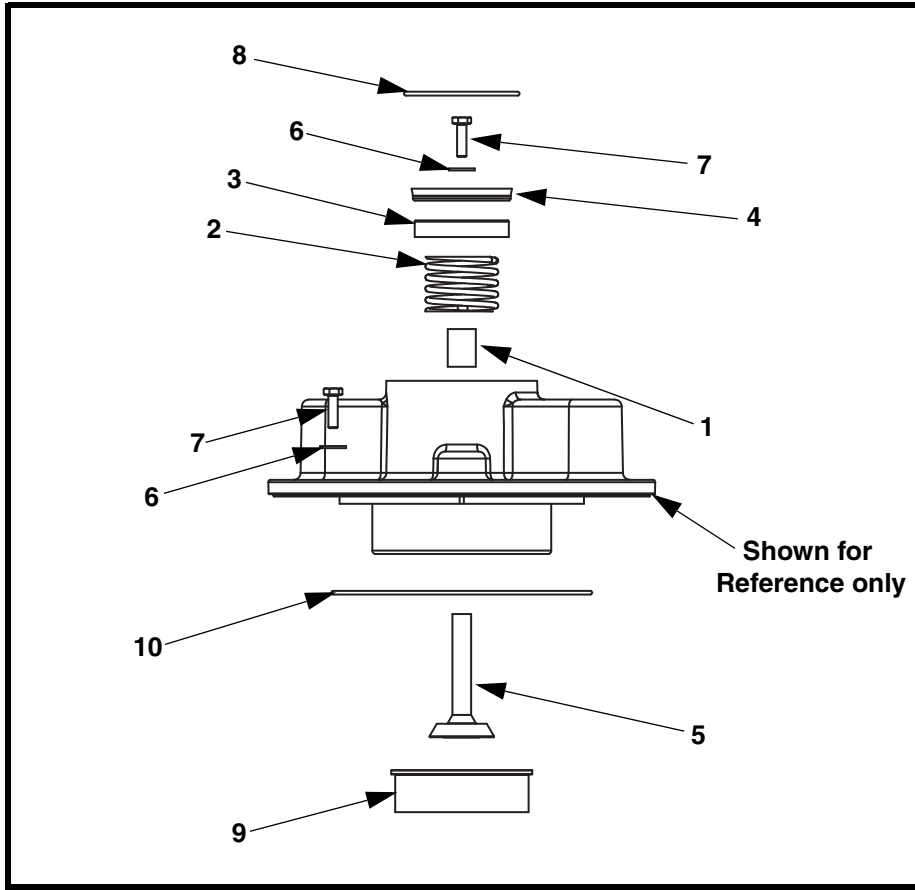
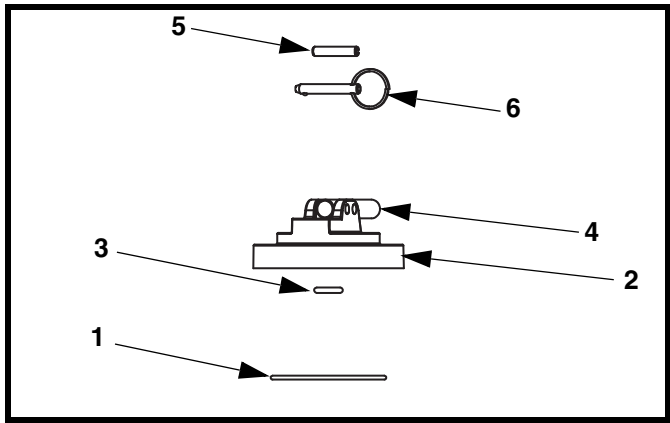

Figure 19. Martin® Hurricane Air Cannon Valve Rebuild Kit, P/N 38137-4

Item	Description	Qty
1	Bearing Sleeve	1
2	Compression Spring 1.937 OD	1
3	Piston	1
4	Lip Seal Puck	1
5	Air Inlet Valve with Brass Seat	1
6	Washer Compression 1/4	7
7	Screw HHC 1/4-20NC x 7/8 ZP	7
8	O-Ring #150 2.862 ID x 1.03 CS	1
9	Urethane Bumper	1
10	O-Ring #166 6.737 ID x .094 CS	1





**Figure 20. Martin® Hurricane Air Cannon Exhaust Valve Cap Replacement Kit, P/N 38136**

Item	Description	Qty
1	O-Ring #150 2.862 ID x 1.03 CS	1
2	Top Cap	1
3	O-Ring #206 .484 ID x .139 CS	1
4	Handle	1
5	Slotted Spring Pin 1/4 x 1-1/4 SS	1
6	Quick Release Pin 1/4 x 1.63 ZP	1

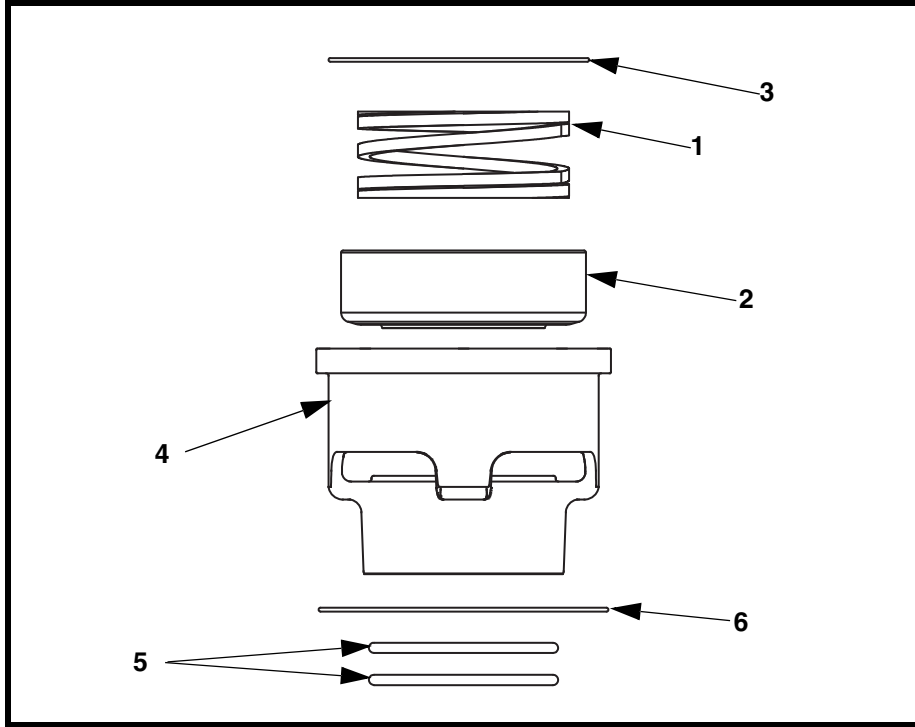
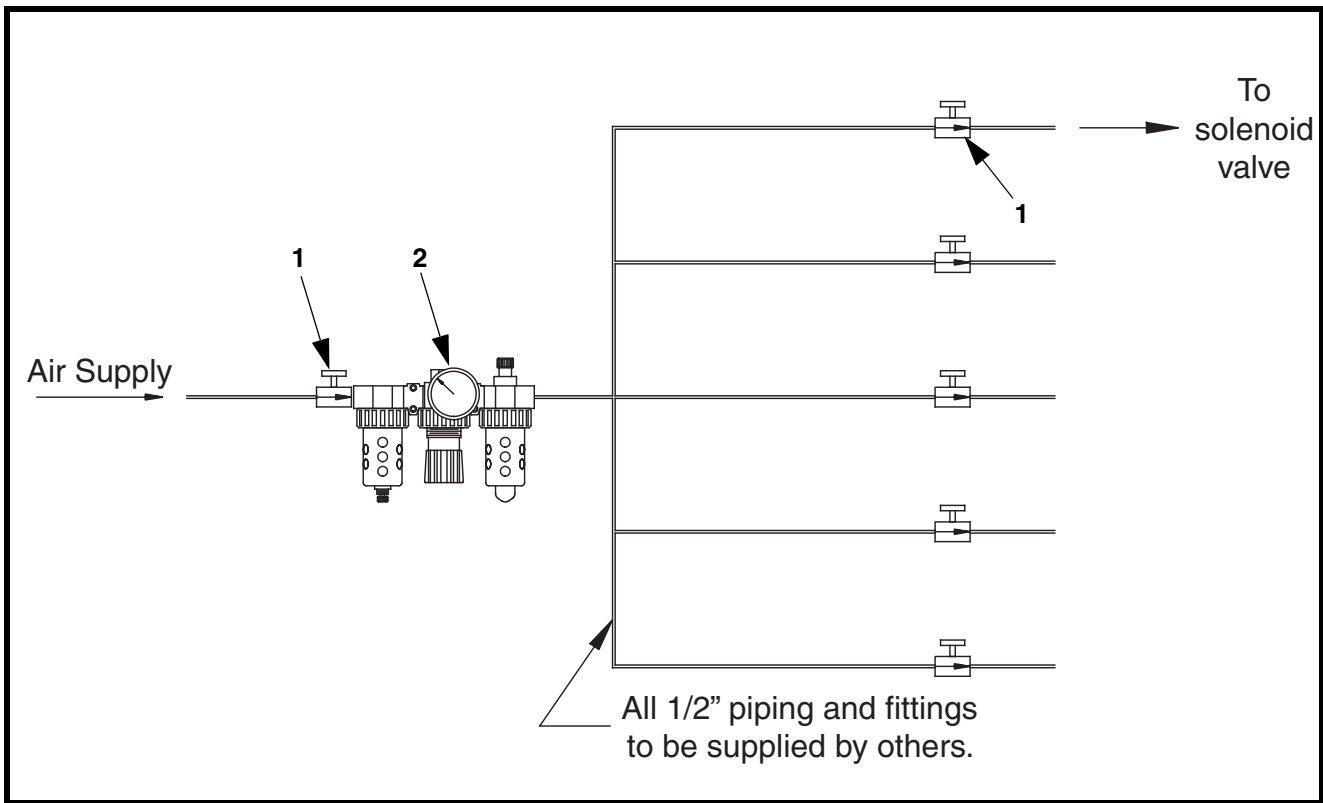

Figure 21. Martin® Hurricane Air Cannon Main Piston Rebuild Kit, P/N 38426

Item	Description	Qty
1	Compression Spring	1
2	4.00" Piston Assembly	1
3	O-Ring #166 6.737 ID x .094 CS	1
4	Basket	1
5	O-Ring #425 4.500 ID x .275 CS	2
6	O-Ring #169 7.487 ID x .103 CS	1



**Figure 22. Air Cannon Air Fill Kit, P/N 37890-XX\***

Item	Description	Part No.	Qty
1	Valve Ball Lockout/Shutoff 1/2 NPT	32284-01	Table I
2	FRL 1/2 NPT	14760	1

\*XX indicates the number of air cannons on the system

**Table I. Air Cannon Air Fill Kit Quantities**

P/N	Qty Item 1
37890-01	1
37890-02	3
37890-03	4
37890-04	5
37890-05	6
37890-06	7
37890-07	8
37890-08	9
37890-09	10
37890-10	11

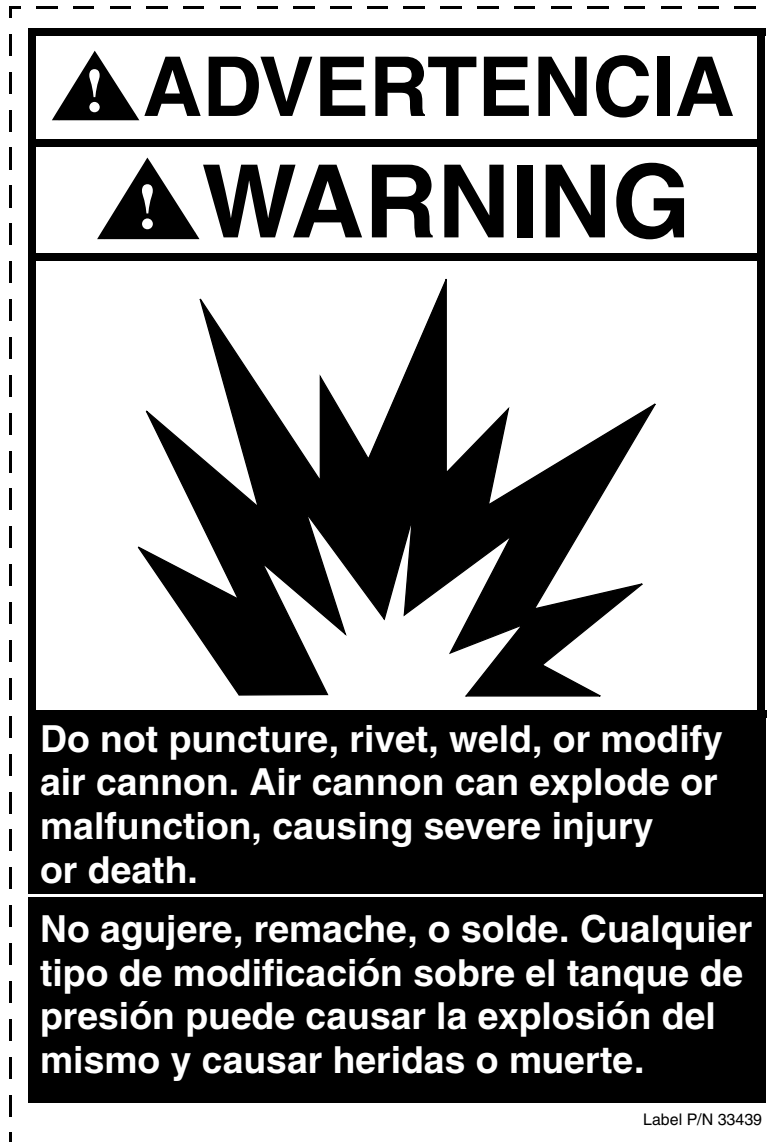

Figure 23. Air Cannon Warning Label, P/N 33439



Figure 24. Martin® Serial/Model Number Label, P/N 21313



Figure 25. Air Blast Warning Label, P/N 31913

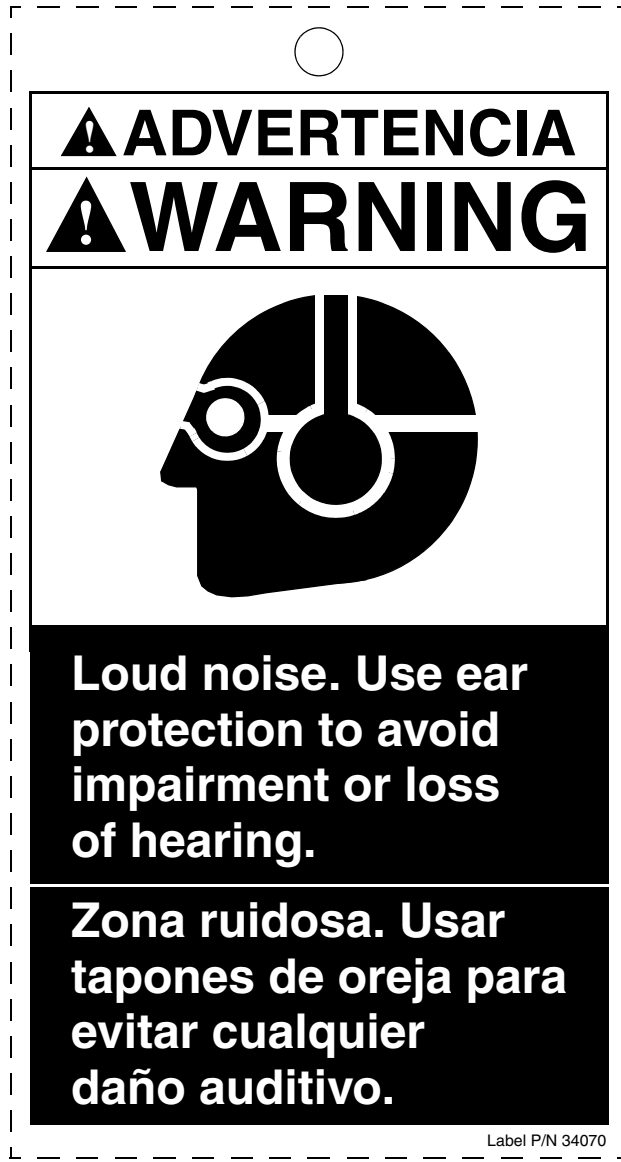
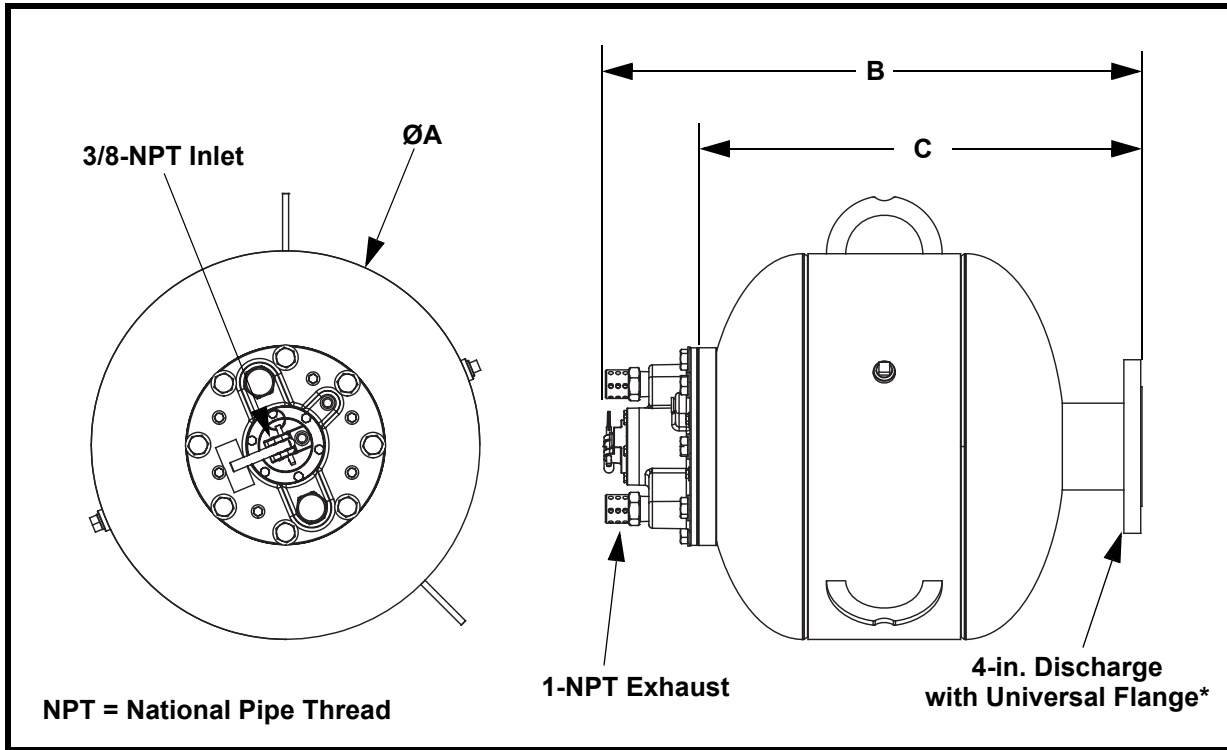

Figure 26. Loud Noise Warning Tag, P/N 34070

**Appendix A**  
**Martin® Hurricane Air Cannon**  
**Specifications and Performance Data**

## Air Cannon Dimensions



\*Fits ANSI and DIN bolt patterns.

P/N	Dim. A in. (mm)	Dim. B in. (mm)	Dim. C in. (mm)	Shipping Weight lb (kg)
38005-35	16.0 (406)	25.89 (658)	21.00 (533)	94 (43)
38005-70	20.0 (508)	27.89 (708)	23.00 (584)	109 (49)
38005-150	24.0 (610)	35.64 (905)	30.75 (781)	173 (78)

Air Volume in ft <sup>3</sup> (Liters) Free Air			
Air Pressure PSIG	38005-35 ft <sup>3</sup> (L)	38005-70 ft <sup>3</sup> (L)	38005-150 ft <sup>3</sup> (L)
0	1.2 (35)	2.4 (70)	5.3 (150)
40	4.6 (130)	9.2 (260)	19.7 (558)
50	5.4 (154)	10.8 (308)	23.3 (660)
60	6.3 (178)	12.5 (355)	26.9 (762)
70	7.1 (201)	14.2 (403)	30.5 (864)
80	8.0 (227)	15.9 (450)	34.1 (966)
90	8.8 (249)	17.6 (498)	37.8 (1020)
100	9.6 (272)	19.2 (546)	41.4 (1172)
110	10.5 (297)	20.9 (593)	45.0 (1274)
120	11.3 (320)	22.6 (641)	48.6 (1376)



# Martin® Hurricane Air Cannon Performance Data

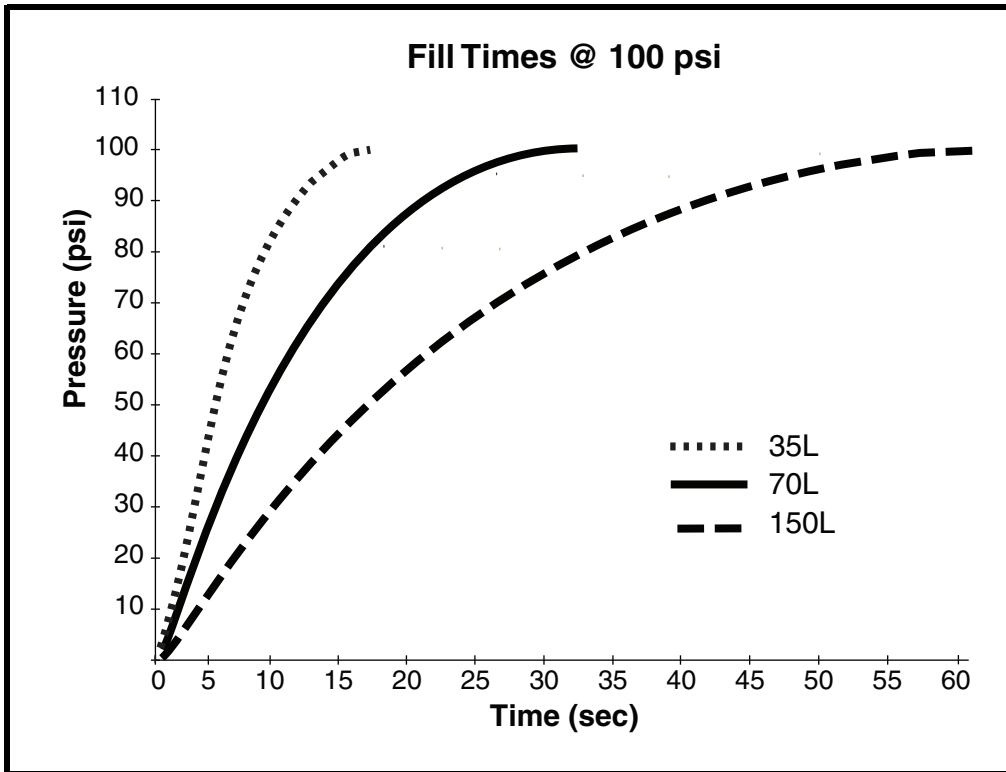
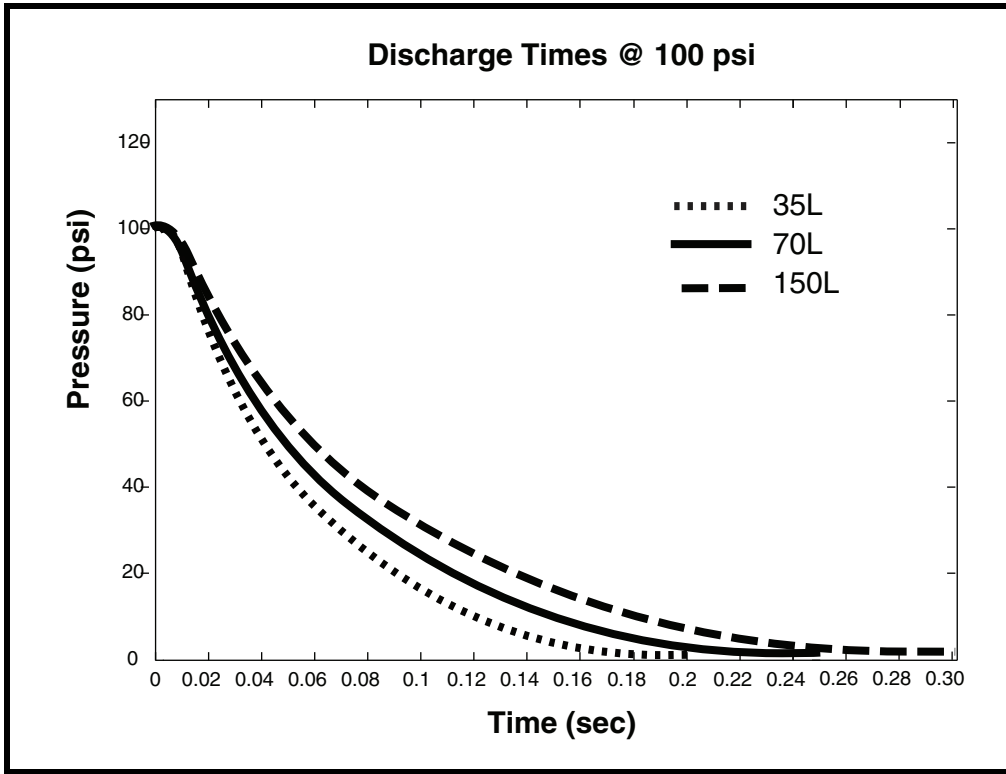



*Any product, process, or technology described here may be the subject of intellectual property rights reserved by Martin Engineering Company. Trademarks or service marks designated with the ® symbol are registered with the U.S. Patent and Trademark Office and may be proprietary in one or more countries or regions. Other trademarks and service marks belonging to Martin Engineering Company in the United States and/or other countries or regions may be designated with the “TM” and “SM” symbols. Brands, trademarks, and names of other parties, who may or may not be affiliated with, connected to, or endorsed by Martin Engineering Company, are identified wherever possible. Additional information regarding Martin Engineering Company’s intellectual property can be obtained at [www.martin-eng.com/trademarks](http://www.martin-eng.com/trademarks).*

# Problem Solved™ GUARANTEED!

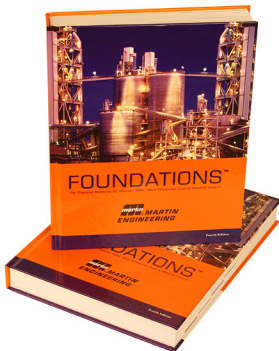

*For nearly 20 years, Martin Engineering's Foundations™ Books have taught industry personnel to operate and maintain clean and safe belt conveyors. The Foundations™ Book, fourth edition, focuses on improving belt conveyors by controlling fugitive material. "The Practical Resource for Total Dust and Material Control," is a 576-page hard cover volume that provides information of value to industries where the efficient handling of bulk materials is a key to productivity and profitability.*

*Expanding upon the book, our Foundations™ Training Program addresses the design and development of more productive belt conveyors, and is offered in three customizable seminars. Attendees gain a better understanding of conveyor safety and performance, helping to justify upgrade investments and increase profitability.*



**Martin Engineering Australia Pty Ltd.**  
102 Christensen Road South  
Stapylton QLD 4207 - Australia  
+61 1300 627 364  
salesau@martin-eng.com | www.martin-eng.com.au

