

Martin® Tracker™

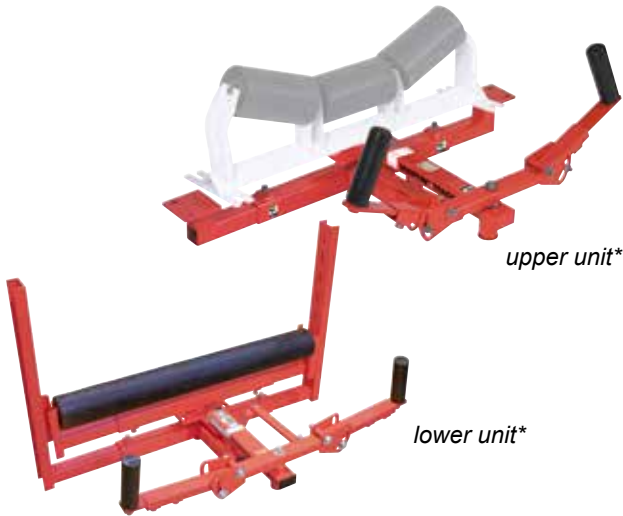

The [Martin® Tracker™](#) provides immediate, continuous precision adjustment of wandering conveyor belts. The Martin® Tracker™ Belt Tracking System works where other belt training devices fail to reduce edge damage, prevent spillage, and extend belt life.

Available in Lower Units for the conveyor's return side and Upper Units for installation on the carrying side of the conveyor, Martin® Tracker units are available in three models to match application conditions.

NOMENCLATURE

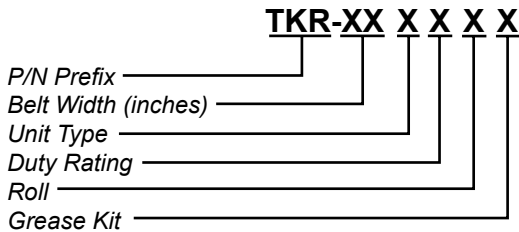

INSTALLATION GUIDELINES

To keep the belt centered in the loading zone, Martin Engineering recommends the installation of one Martin® Tracker™ Lower Unit on the conveyor's return side at a point approximately five times the belt width before the belt reaches the tail pulley. A Martin® Tracker™ Upper Unit should be installed after the load zone on belts wider than 42 inches (1000 mm). Additional units may be needed to keep the belt tracking perfectly.

UNIT TYPE

- U:** Upper
- L:** Lower

ROLL (Lower Tracker only)

- R:** With Rubber-Lagged Roll
- Ø:** Without Rubber-Lagged Roll

DUTY RATING

- S:** Standard Duty
- H:** Heavy Duty
- M:** Monster

GREASE OPTIONS

- G:** With Grease Kit
- Ø:** Without Grease Kit

NOTES

The steering roll on the Martin® Tracker™ must be supplied by the customer. Typically the steering roll is an existing customer roller that was removed from the conveyor to allow installation of the belt tracking system. The Martin® Tracker™ Units work best with a rubber or rubber-covered steering roll.

This Martin® Tracker™ is not suitable for reversing conveyors or belts with substantial rollback. For reversing applications contact Martin Engineering.

DUTY RATING

Standard-Duty

The Martin® Tracker™ is designed for applications under typical industrial material handling conditions.

Heavy-Duty

The Martin® Tracker™ HD is designed to withstand the stress associated with wider, thicker belts moving at higher speeds and carrying heavier loads.

Monster

The Martin® Tracker™ Monster is engineered to survive in the most rugged of applications.

TECHNICAL DATA SHEET

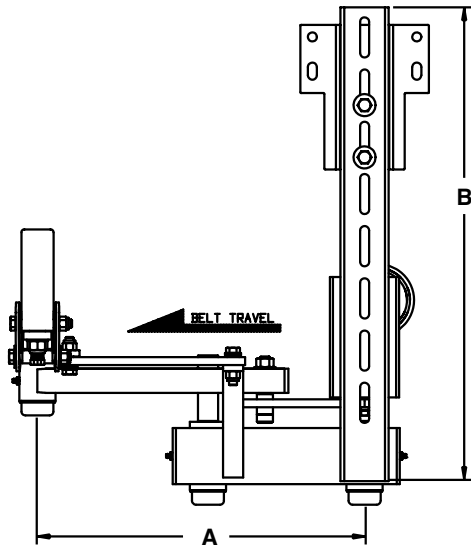

Martin® Tracker™
Lower Unit Assembly*

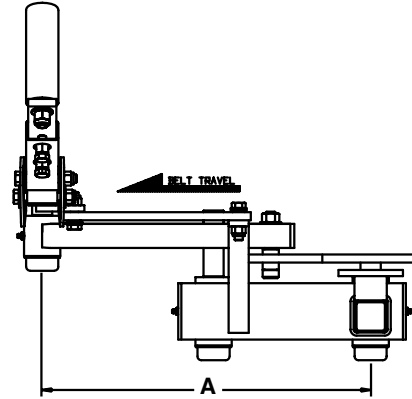

Martin® Tracker™
Upper Unit Assembly*

DIMENSIONS

Duty Rating	Lower Unit		Upper Unit	
	Dim. A in. (mm)	Dim. B in. (mm)	Dim. A in. (mm)	
Standard Duty	20.38 (518)	29.50 (749)	20.38 (518)	
Heavy Duty	25.17 (639)	33.50 (851)	25.17 (639)	

* Idler Roll is shown for reference only and is not included with order.

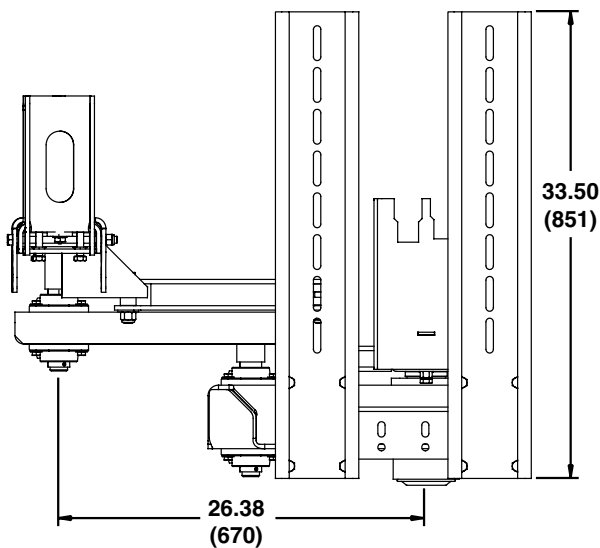

Martin® Tracker™ Monster
Lower Unit Assembly*

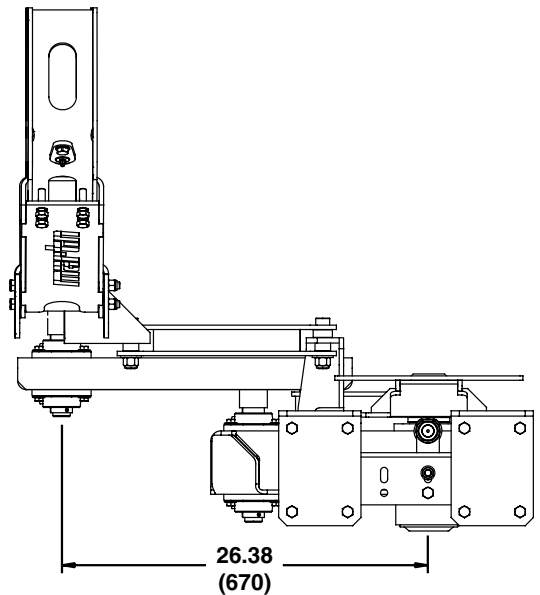

Martin® Tracker™ Monster
Upper Unit Assembly*

TECHNICAL DATA SHEET

SELECTION GUIDE

The Martin® Tracker™ is available in three models to match the requirements of each application.

Select the appropriate unit based on belt thickness and conveyor speed.

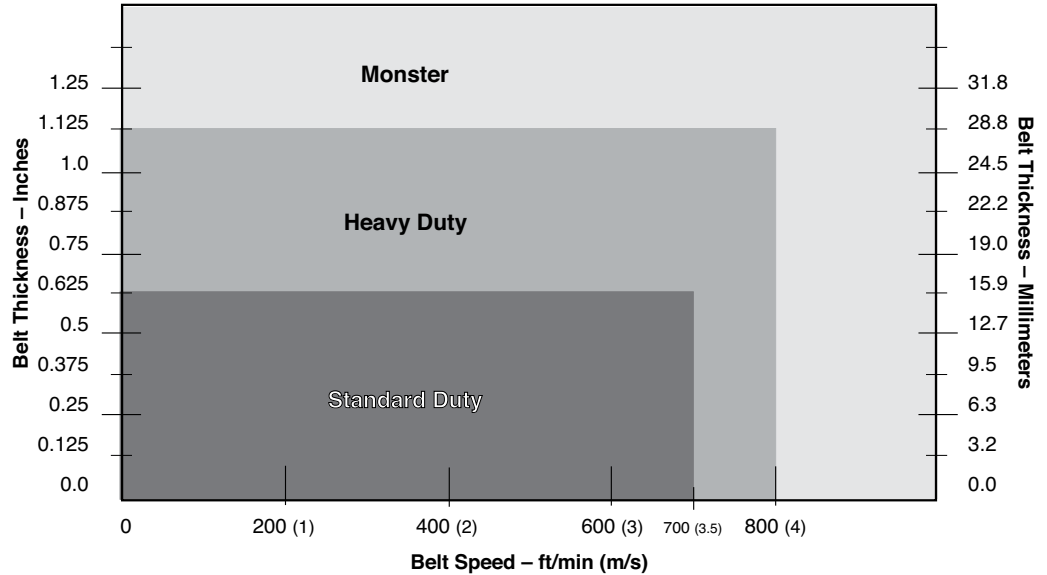

ORDER INFORMATION

	Belt Width in. (mm)	Upper Unit		Lower Unit	
		P/N	Ship Weight lb (kg)	P/N	Ship Weight lb (kg)
STANDARD DUTY	24 (500-600)	TKR-24US	86 (39)	TKR-24LS	138 (63)
	30 (650-800)	TKR-30US	86 (39)	TKR-30LS	140 (64)
	36 (800-1000)	TKR-36US	89 (40)	TKR-36LS	142 (64)
	42 (1000-1200)	TKR-42US	98 (44)	TKR-42LS	155 (70)
	48 (1200-1400)	TKR-48US	98 (44)	TKR-48LS	155 (70)
	54 (1400-1600)	TKR-54US	99 (45)	TKR-54LS	155 (70)
HEAVY DUTY	36 (800-1000)	TKR-36UH	170 (77)	TKR-36LH	253 (115)
	42 (1000-1200)	TKR-42UH	180 (82)	TKR-42LH	275 (125)
	48 (1200-1400)	TKR-48UH	190 (86)	TKR-48LH	278 (126)
	54 (1400-1600)	TKR-54UH	195 (88)	TKR-54LH	282 (128)
	60 (1600-1800)	TKR-60UH	214 (97)	TKR-60LH	321 (146)
	72 (1800-2000)	TKR-72UH	214 (97)	TKR-72LH	321 (146)
MONSTER	42 (1000-1200)	37249-42UM	250 (113)	37249-42LM	415 (188)
	48 (1200-1400)	37249-48UM	250 (113)	37249-48LM	420 (191)
	54 (1400-1600)	37249-54UM	250 (113)	37249-54LM	423 (192)
	60 (1600-1800)	TKR-60UM	660 (300)	TKR-60LM	685 (311)
	66 (1600-1800)	TKR-66UM	680 (308)	TKR-66LM	710 (322)
	72 (1800-2000)	TKR-72UM	715 (324)	TKR-72LM	730 (331)
	84 (2000-2200)	TKR-84UM	760 (345)	TKR-84LM	775 (352)
	96 (2200-2400)	TKR-96UM	815 (370)	TKR-96LM	815 (370)
	108 (2400-2700)			37249-108LM	486 (220)

NOMENCLATURE

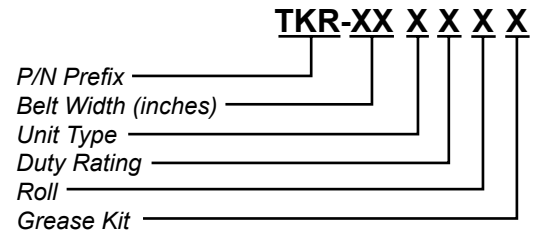

UNIT TYPE

U: Upper
L: Lower

DUTY RATING

S: Standard Duty
H: Heavy Duty
M: Monster

ROLL (Lower Tracker only)

R: With Rubber-Lagged Roll
Ø: Without Rubber-Lagged Roll

GREASE OPTIONS

G: With Grease Kit
Ø: Without Grease Kit

Optional equipment for TKR-XXUM P/Ns:

TM12EXP-XXXXXXXL Idler Sets

Available in 20°, 35°, & 45° trough angles



Martin Engineering Australia Pty Ltd.
102 Christensen Road South
Stapylton QLD 4207 - Australia
+61 1300 627 364
salesau@martin-eng.com | www.martin-eng.com.au



Problem Solved GUARANTEED!

Form No. L3298-11-11/20
© Martin Engineering Company 1997, 2020