

Martin® SQC2S™ Secondary Cleaner with Orion Blades

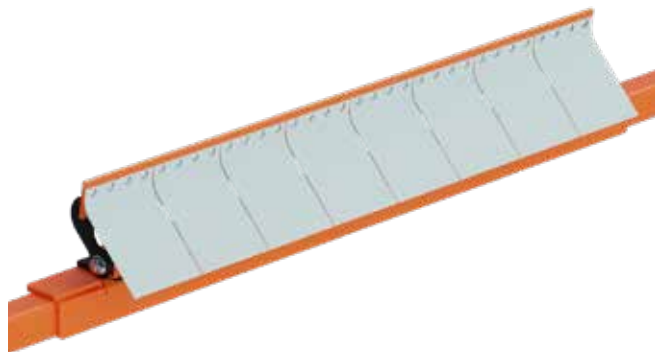

SQC2S™ Cleaner with Orion Blades utilize a unique flexing blade mount to cushion splice impact while maintaining cleaning pressure. The blade’s “paint-scraper” cleaning angle provides maximum removal of stubborn carryback while the blade holder flexes to allow the blade tip to deflect in the direction of belt travel for splice passage. Tungsten carbide blade tips featuring individually machined blade adjustment provide effective and long-lasting cleaning while the unique blade shield allows removed material to slide off without buildup.

BENEFITS

- “Paint-scraper” cleaning angle provides maximum removal of conveyor belt carryback.
- Tungsten carbide blade tips provide effective and long-lasting cleaning.
- Blade shield allows removed material to slide off without buildup.
- Blade holder flexes to allow tip to deflect in the direction of belt travel for splice passage and has individual machined blade adjustment.

ACCESSORIES

PART	P/N
Martin® SQC2™ Split-Cover Door—Steel	38014-SQCS
Martin® SQC2™ Split-Cover Door—Stainless Steel	38014-SQCSS
Martin® Hanger Mount Heavy-Duty Assembly	34233-HD
Martin® SQC2S™ Square Mainframe Tensioner HD	38664-HD

NOMENCLATURE

SQC2S-XX X XX RO X X X

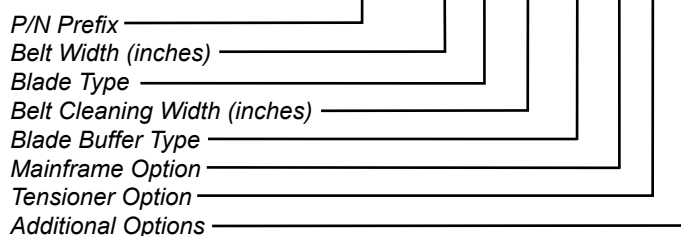

BLADE TYPE

- S:** 316 Stainless Steel Blade with Teflon Deflector
- T:** Mild Steel Blade Painted with Teflon Deflector
- W:** Mild Steel Blade Painted with Polyethylene Deflector
- N:** No Blades

BLADE CLEANING WIDTH

Full belt width or approximately 6 inches less belt width

BLADE BUFFER TYPE

RO: Rosta

MAINFRAME OPTIONS

- P:** Painted
- S:** Stainless

TENSIONER OPTIONS

- H:** HD Tensioner
- G:** 316 SS HD Tensioner
- N:** No Tensioner

ADDITIONAL OPTIONS

- N:** None
- D:** Dust-Tight Steel Cover Door
- S:** Dust-Tight Stainless Steel Cover Door

MARTIN® SQC2S™ ORION BLADES*

COLOR	GENERAL APPLICATION	Replacement Blade P/N
Orange	Stainless Steel with TC Tips and Teflon deflector	OR-52000-6S
—	TC Blade with Teflon deflector	OR-52000-6T
—	TC blade with Polyethylene deflector – General Conditions	OR-52000-6W

* Maximum belt speed for Martin® SQC2S™ blades is 1500 FPM. Stainless steel assemblies available upon request. For other applications, please contact your Martin Engineering representative. TC = Tungsten

TECHNICAL DATA SHEET

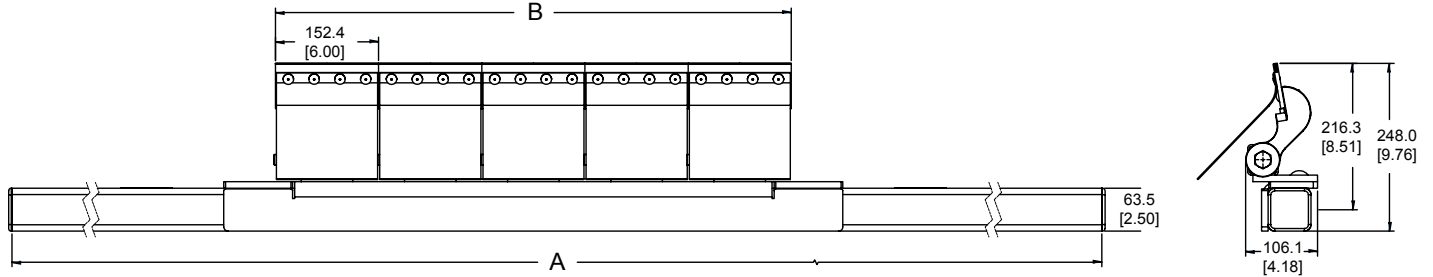

DIMENSIONS

PART NUMBER	DIM A	DIM B
SQC2S-18X12ROXXX	1676.4 (66.00)	304.8 (12.00)
SQC2S-18X18ROXXX	1676.4 (66.00)	457.2 (18.00)
SQC2S-24X18ROXXX	1828.8 (72.00)	457.2 (18.00)
SQC2S-24X24ROXXX	1828.8 (72.00)	609.6 (24.00)
SQC2S-30X24ROXXX	1981.2 (78.00)	609.6 (24.00)
SQC2S-30X30ROXXX	1981.2 (78.00)	762.0 (30.00)
SQC2S-36X30ROXXX	2133.6 (84.00)	762.0 (30.00)
SQC2S-36X36ROXXX	2133.6 (84.00)	914.4 (36.00)
SQC2S-42X36ROXXX	2286.0 (90.00)	914.4 (36.00)
SQC2S-42X42ROXXX	2286.0 (90.00)	1066.8 (42.00)
SQC2S-48X42ROXXX	2438.4 (96.00)	1066.8 (42.00)
SQC2S-48X48ROXXX	2438.4 (96.00)	1219.2 (48.00)
SQC2S-54X48ROXXX	2590.8 (102.00)	1219.2 (48.00)
SQC2S-54X54ROXXX	2590.8 (102.00)	1371.6 (54.00)
SQC2S-60X54ROXXX	2743.2 (108.00)	1371.6 (54.00)
SQC2S-60X60ROXXX	2743.2 (108.00)	1524.0 (60.00)
SQC2S-66X60ROXXX	2895.6 (114.00)	1524.0 (60.00)
SQC2S-66X66ROXXX	2895.6 (114.00)	1676.4 (66.00)
SQC2S-72X66ROXXX	3048.0 (120.00)	1676.4 (66.00)
SQC2S-72X72ROXXX	3048.0 (120.00)	1828.8 (72.00)
SQC2S-78X72ROXXX	3200.4 (126.00)	1828.8 (72.00)
SQC2S-78X78ROXXX	3200.4 (126.00)	1981.2 (78.00)
SQC2S-84X78ROXXX	3352.8 (132.00)	1981.2 (78.00)
SQC2S-84X84ROXXX	3352.8 (132.00)	2133.6 (84.00)
SQC2S-90X84ROXXX	3505.2 (138.00)	2133.6 (84.00)
SQC2S-90X90ROXXX	3505.2 (138.00)	2286.0 (90.00)
SQC2S-96X90ROXXX	3657.6 (144.00)	2286.0 (90.00)
SQC2S-96X96ROXXX	3657.6 (144.00)	2438.4 (96.00)

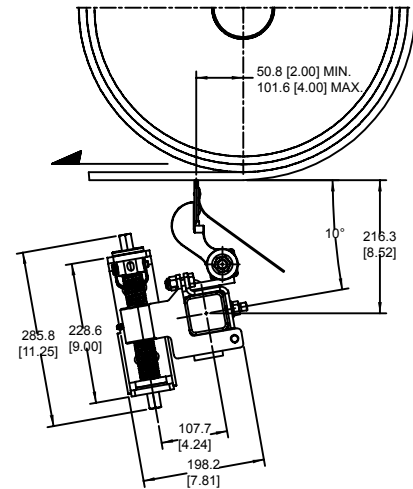

Detail With Tensioner Mounted On Left Side
Note: Cover Door Not Shown For Clarity

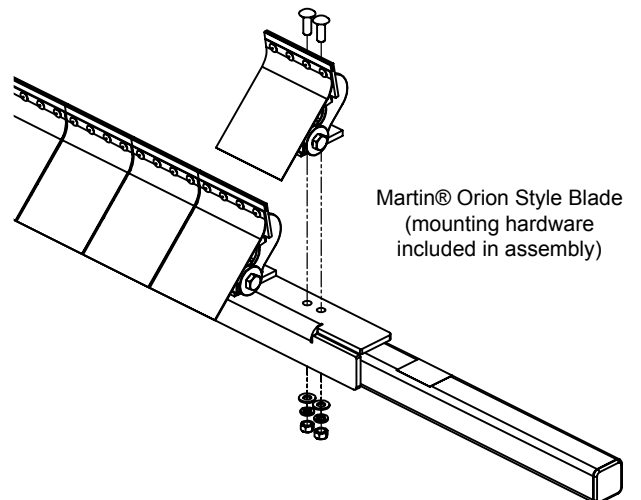

Martin® Orion Style Blade
(mounting hardware included in assembly)



Martin Engineering USA
102 Christensen Road South
Stapylton QLD 4207 - Australia
+61 1300 627 364
salesau@martin-eng.com | www.martin-eng.com.au

**COMPANY WITH
QUALITY SYSTEM
CERTIFIED BY DNV GL
= ISO 9001 =**