

Martin® Return Roller

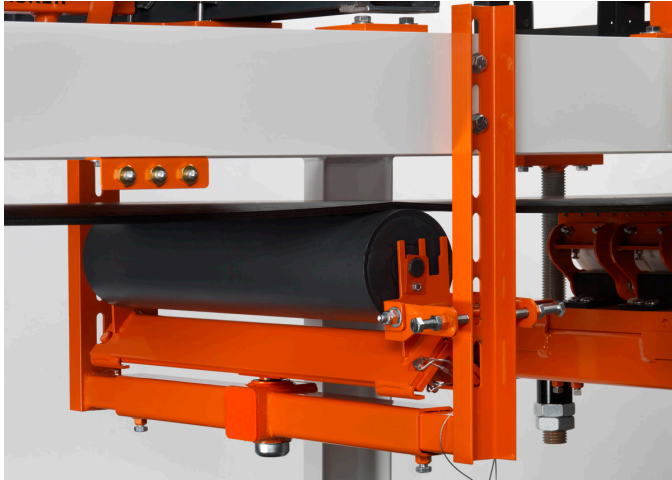

The [Martin® Return Roller](#) is a pivoting track-mounted return idler that allows for safe, quick, and simple one-sided serviceability and roll replacement.

The track-mounted design reduces the risk of injury and allows replacement of the roll in a matter of seconds.

NOMENCLATURE **UCRR-007000-XX X***

P/N Prefix _____
 Belt Width _____
 Stringer _____

STRINGER
S: Standard Stringer

*Add an (F) at the end of the part number for frame only (no roll included).

DIMENSIONS – in. (mm)

Part Number	Dim. A in. (mm)	Dim. B in. (mm)
UCRR-007000-24S	36 (914)	29 (737)
UCRR-007000-36S	48 (1219)	37 (940)
UCRR-007000-42S	54 (1372)	43 (1092)
UCRR-007000-48S	60 (1524)	47 (1194)
UCRR-007000-54S	66 (1676)	55 (1397)
UCRR-007000-60S	72 (1829)	51 (1295)
UCRR-007000-72S	84 (2134)	61 (1549)

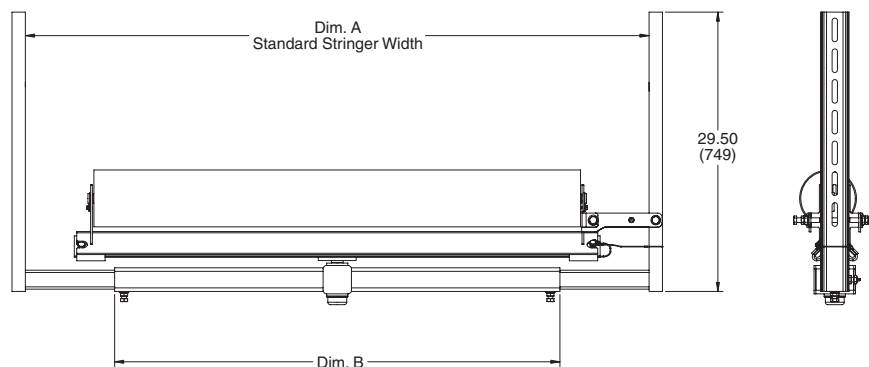

Martin Engineering Australia Pty Ltd.
 102 Christensen Road South
 Stapylton QLD 4207 - Australia
 +61 1300 627 364
 salesau@martin-eng.com | www.martin-eng.com.au

