

Martin® Multi Valve Air Cannon



The [Martin® Multi Valve Air Cannon](#) uses a single tank to blast into as many as five discharge ports from a single location.

The Martin® Multi Valve Air Cannon is ideal for installations with multiple discharge points located in close proximity. By separating the air cannon valves from the discharge points, working components are protected from dust, gases, and heat conditions, while installation and maintenance are simplified.

BENEFITS

- Effective Flow Enhancement**
 From one location, the Martin® Multi Valve Air Cannon boosts flow at up to five points in a vessel.
- Centralized Maintenance**
 Easy access for installation, inspection, and maintenance.
- Reduced Exposure to Heat and Dust**
 By removing the air cannon valve from the discharge point, vital components are placed farther away from excessive heat and dust.
- 5-in-1 System**
 Five Martin® Hurricane Air Cannon Valves share one tank, but operate like five individual air cannons.

PERFORMANCE DATA

Discharge Times @ 100 psi

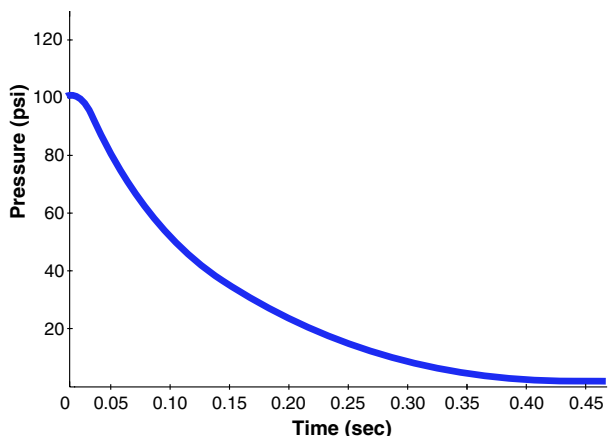

Fill Times @ 100 psi

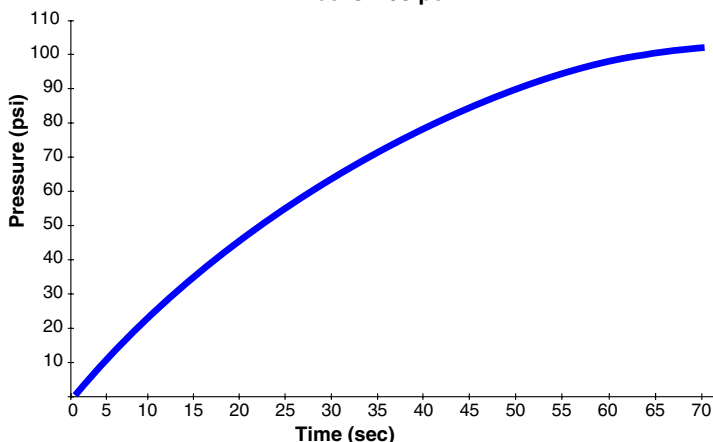

TECHNICAL DATA SHEET

DIMENSIONS — in. (mm)

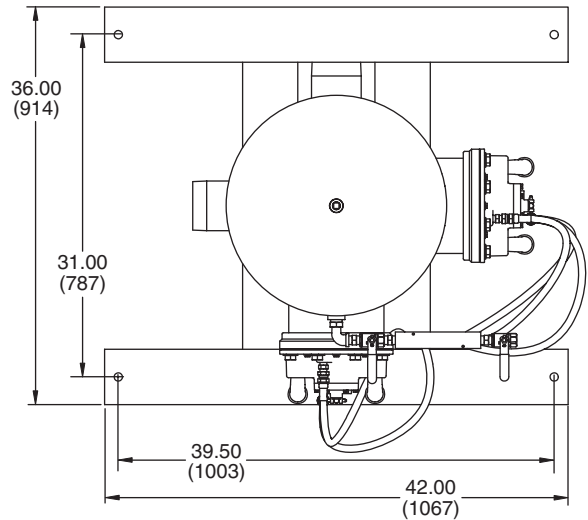
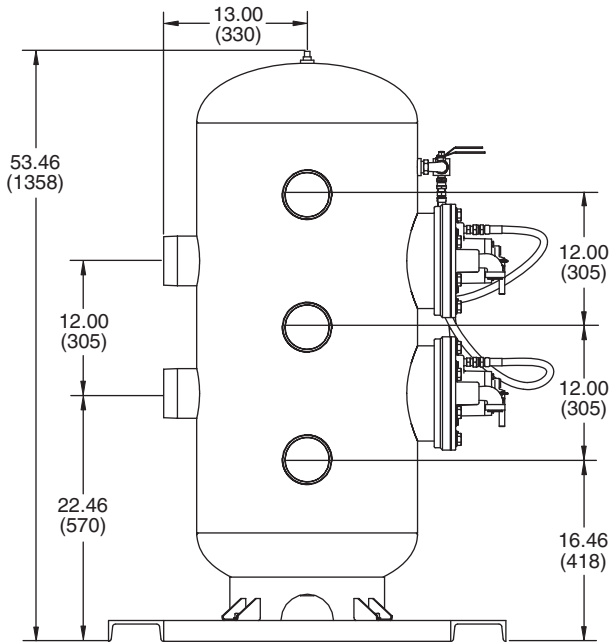

AIR VOLUME IN FT³ (LITERS) FREE AIR

Air Pressure PSI	Volume ft ³ (L)
0	7.9 [225]
40	29.6 [838]
50	35.0 [991]
60	40.4 [1144]
70	45.8 [1297]
80	51.2 [1450]
90	56.6 [1604]
100	62.0 [1757]
110	67.5 [1910]
120	72.9 [2063]

NOTES

The Martin® Multi-Valve Air Cannon weighs approximately 535 lbs (243 kg).

Tanks for Martin® Air Cannons supplied by Martin Engineering are manufactured to ASME Code Rules, Section VIII, Division 1. Tanks are National Board registered and pressure vessel quality (PVQ).

For further information, contact Martin Engineering at 1-800-544-2947 or visit our website at www.martin-eng.com.



Martin Engineering Australia Pty Ltd.
 102 Christensen Road South
 Stapyhton QLD 4207 - Australia
 +61 1300 627 364
salesau@martin-eng.com | www.martin-eng.com.au

