

Martin® Idler Conversion Kit

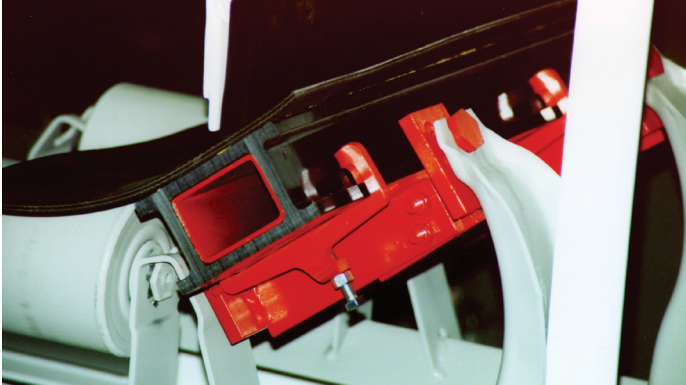

Eliminate Sag, Spillage, and Material Entrapment
 Improve Belt Support with Martin® Slider Bars.

The [Martin® Idler Conversion Kit](#) improves a conveyor's belt support system, stabilizing the line, improving sealing, and preventing spillage. This simple kit links two more troughing idler frames, replacing the wing rollers with Martin® Slider Bars.

BENEFITS

- **Stable Belt Line Improves Sealing**
 No more sag, no more spillage. Edge sealing systems work more effectively on stable belt line.
- **Prevents Entrapment Damage**
 Without sag, there's no risk of material becoming wedged in pinch point to gouge belt.
- **Economical Conveyor Upgrade**
 Reuse existing idler frames and center rollers for a cost-conscious system improvement.
- **Reduces Maintenance**
 No adjustment necessary; no lubrication required.
- **Low Friction Surface**
 Improve belt support without increasing drive power requirements.
- **Flexible Placement**
 Custom-length bars improve belt support points where conveyor needs it most, including tight spaces.
- **Simple to Install**
 Replace wing rollers easily; kit conforms to wide range of idler manufacturers.

PROBLEMS

Belt sag between idlers allows spillage, creating maintenance problems, cleanup costs, and regulatory issues.

Entrapped material gouges belt cover, shortening belt life.

SOLUTION

Stable sag-free belt line allows improved sealing for reduced spillage and reduced maintenance problems.

No bearings to seize; no lubrication required.

NOTES

Martin® Slider Cradles are designed to work with CEMA B, C and D belts with a maximum notch in the frame of 1.06 in.

Double Bar Conversion Kits are recommended for applications where conveyor capacity is more than 450 tons (408 metric tons) per hour, or where the wing rolls are longer than 13 inches (330 mm), as typically seen on belts over 36 inches (900 mm) wide.

Wing Roll must be a minimum of 14 1/2 in. to hold two bars.

To add an additional bar to belt widths less than 8" order P/N 37613. P/N 37613 contains 1 clamp assembly. Need 2-37613 per bar.

When installing more than four feet (1.2 m) of Martin® Slider Cradles, it is necessary to check for adequate power in the conveyor drive to overcome the additional friction against the belt. Contact Martin Engineering for additional information.

Martin® Slider Cradles are not recommended for conveyors operating at speed over 700 fpm (3.5 m/sec) or conveyors less than 50 ft (15 m) in length.

To improve belt support on short conveyors or high-speed belts, contact Martin Engineering.

TECHNICAL DATA SHEET

CONVERSION KIT

Select by belt width

Each kit includes idler conversion brackets and clamps for one idler set.

Note: Conversion kit does not include slider bars. Slider bars must be ordered separately.

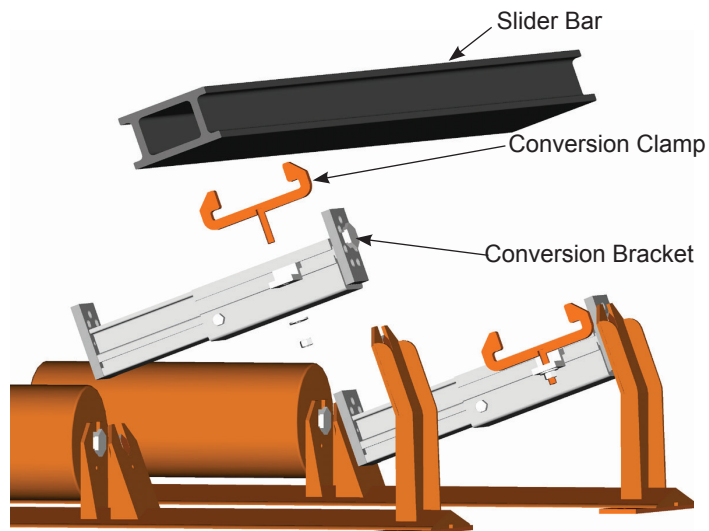

| Belt Width in. (mm) | P/N | Conversion Clamp QTY |
|------------------------|-----------|-------------------------|
| 24 (610) | 37135-K24 | 2 |
| 30 (762) | 37135-K30 | 2 |
| 36 (914) | 37135-K36 | 2 |
| 42 (1067) | 37135-K42 | 2 |
| 48 (1219) | 37135-K48 | 4 |
| 54 (1372) | 37135-K54 | 4 |
| 60 (1524) | 37135-K60 | 4 |
| 66 (1676) | 37135-K66 | 4 |
| 72 (1829) | 37135-K72 | 4 |
| 84 (2134) | 37135-K84 | 4 |
| 96 (2438) | 37135-K96 | 4 |

SLIDER BAR

Select by length of bar required

| Bar Length ft. (mm) | P/N |
|------------------------|------------|
| 3 (914) | 37135-B36 |
| 4 (1219) | 37135-B48 |
| 5 (1424) | 37135-B60 |
| 6 (1829) | 37135-B72 |
| 7 (2134) | 37135-B84 |
| 8 (2438) | 37135-B96 |
| 9 (2743) | 37135-B208 |
| 10 (3048) | 37135-B120 |
| 11 (3353) | 37135-B132 |
| 12 (3568) | 37135-B144 |

TO ORDER:

Measure distance supported and count the idlers to be converted.

| Example | | Correct Order | |
|--|--------------------|----------------------------------|-------------|
| Belt Width | 30 in. (762 mm) | Coversions Kit: P/N 37135-K30 | Quantity: 8 |
| Distance to be Converted (Ea. Side) | 32 ft. (9.75 m) | Slider Bars: P/N 37135-B96 | Quantity: 8 |
| Number of Idlers to convert: | 8 | | |

Each P/N is one bar; order enough bars for both sides of each cradle. Note if cradles need one bar or two bars per side.



Martin Engineering Australia Pty Ltd.
 102 Christensen Road South
 Stapylton QLD 4207 - Australia
 +61 1300 627 364
 salesau@martin-eng.com | www.martin-eng.com.au

