

Martin® Dust Curtain Double

Installed at the exit of the loading zone, [Martin® Dust Curtain Double](#) provides effective sealing to prevent the escape of airborne fines. Mounted in the skirtboard cover, the dust curtains help create a plenum for dust suppression and dust collection.

Recommended installation is one curtain without slits closest to loading zone, followed by one curtain with slits at exit of skirtboard. Additional curtains may be installed to reduce air movement and isolate dust suppression or dust collection systems.

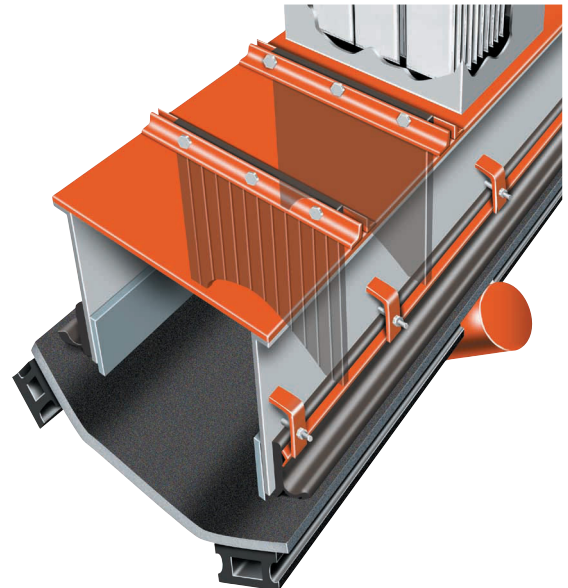

SPECIFICATIONS

Curtain Material:	SBR Rubber 60 durometer
Curtain Width:	Belt width minus 4 in. (100 mm)
Frame Width:	Belt width plus 0.5 in. (12 mm)

NOTES

Skirtboard cover is not supplied.

Curtains are to be trimmed in field to fit conveyor troughing angle and skirtboard height. Recommended trim length is 1 in. (25 mm) lower than fully loaded material profile on belt.

ORDER INFORMATION

Item	Includes	P/N	Nomenclature
Martin® Dust Curtain Double	one curtain with slits one curtain without slits two steel mounting frames	33968-XXX	First XX = Belt Width (in.) Last X = "D" for Double High
Replacement Rubber Curtain	one rubber curtain	33965-XXXX	First XX = Belt Width (in.) Third X = "S" for Slits (if required) Last X = "D" for Double High

TECHNICAL DATA SHEET

DIMENSIONS—in. (mm)

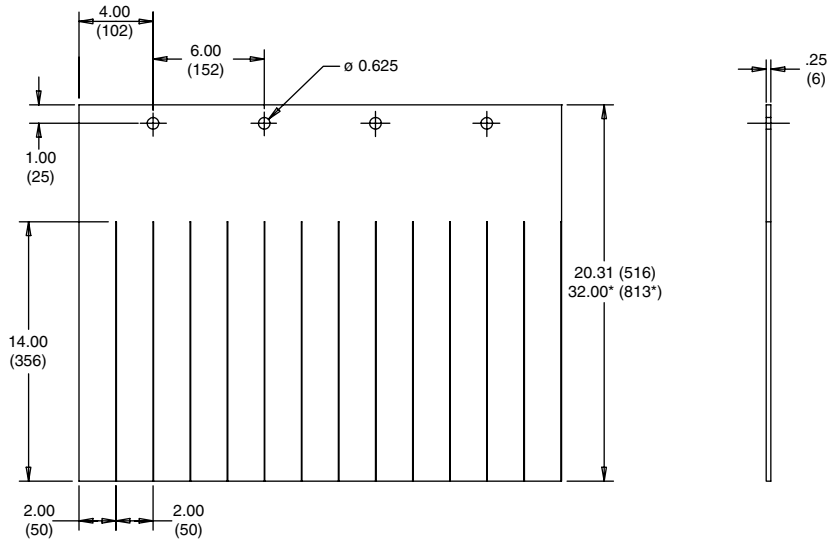

*Second dimension is for Double High.

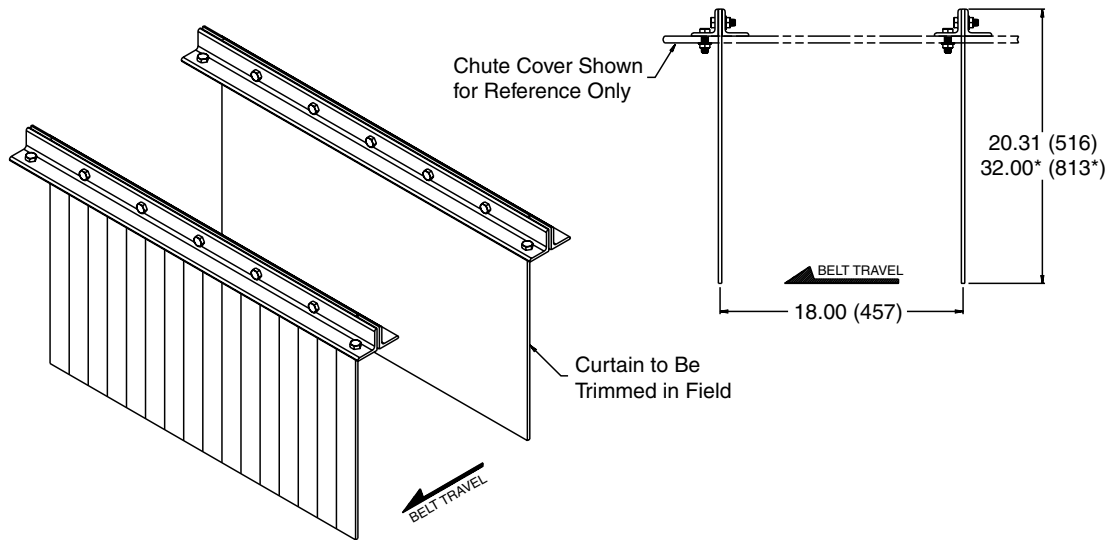

Martin Engineering Australia PTY Ltd.
102 Christensen Road South
Stapylton QLD 4207
+61 1300 627 364
salesau@martin-eng.com
www.martin-eng.com.au

**COMPANY WITH
QUALITY SYSTEM
CERTIFIED BY DNV
= ISO 9001:2008 =**

Problem Solved™ GUARANTEED!

Form No. L3298-06-08/12
© Martin Engineering Company 1997, 2012