

Martin® Air Cleaner with Envelope Filter

To overcome the maintenance problems and operating costs of centralized dust control systems, Martin Engineering recommends the use of a [Martin® Air Cleaner](#) on conveyor transfer points.

Rather than carry dust-laden air to a central collector, insertable systems filter the air inside the transfer point. There is no large fan, no ductwork, and no central bag house. Insertable filters are integrated into the transfer point enclosure, where they can easily return material to the conveying system.

BENEFITS

- **Effective Dust Capture**
High efficiency filters remove 99.9 percent of all particles larger than one micron.
- **Continuous Operation**
Automatic “reverse jet” cleaning sequence keeps filters working effectively with minimum compressed air.
- **Returns Product To The Process**
Dust stays within the transfer point. Valuable material returns to the material handling system.
- **No Dust Disposal**
No haulage costs for waste disposal. Valuable material returns to the process. No equipment needed to handle, package, or dispose of dust.
- **Economical Installation**
No ductwork to install, balance, or clean.
- **Low Energy Costs**
Small, efficient integral fan operates only when conveyor runs.
- **Minimum Maintenance**
“Clean side” access for inspection and filter changeout.
- **Flexible Design**
Stand-alone system or use to supplement existing central dust collector systems.
- **Systems To Fit Your Application**
Martin Engineering offers a full range of system sizes and filter materials to match application requirements.
- **Explosion-Proof Models Available**
Explosion-proof units are supplied with explosion-proof fan motor, spark-resistant fan, NEMA 9 control panel, anti-static filter media, and stainless steel inserts.

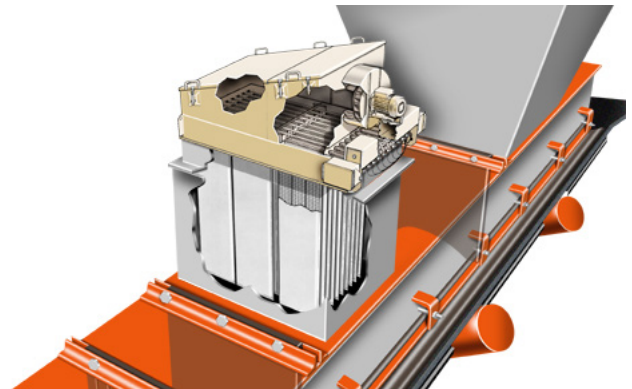

DESIGNED EFFICIENCY

Air Cleaners can effectively handle the heavy concentrations of dust and high volumes of air arising at belt conveyor transfer points.

Martin® Air Cleaners are designed to remove 99.9 percent by weight of all dry particulate particles one micron and larger in size.

(This efficiency is based on a time-weighted average and assures the collector will be installed, operated, and maintained in accordance with instructions.)

SYSTEM REQUIREMENTS

- Compressed Air: 10.2 cfm @ 90-100 psi
- Electrical: 230/460V 3-Phase 60Hz
(also available in 380V/50Hz)
- Max. Operating Temperature: 180°F (82°C)

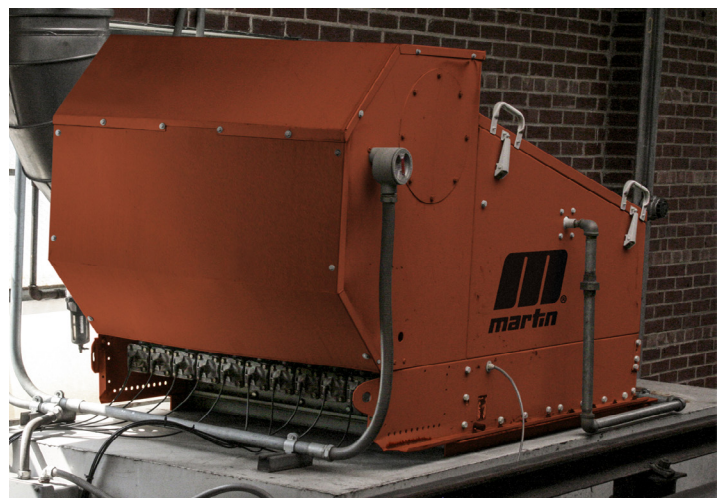

HOW IT WORKS

An integral fan pulls dust-laden air through the filter elements. The air passes through the filter, leaving the particles on the fabric.

Each filter element is regularly cleaned by a "reverse jet" of compressed air, which is injected into the filter element through the jet tube. This causes a momentary reversal of the air flow, resulting in a brief inflation of the filter element, dislodging the dust cake back into the main material body.

SYSTEMS TO FIT YOUR APPLICATION

Martin Engineering offers a full range of system sizes and filter materials to match application requirements. Filters can be installed horizontally or vertically to meet application requirements. Explosion-proof packages are available.

SIZING

Sizing requires measurements of air flow, material conveyed, temperature of material, frequency, and voltage.

The best way to measure the air velocity is to use a hand held anemometer. This small electronic device will provide a display of average velocity of the air in feet per minute. By placing the anemometer in the flow of the air as it exits the end of the transfer point chute, the air velocity for the transfer point can be determined.

Once the air velocity is determined, the cross sectional area of the transfer point chute must be measured. This should be recorded in units of feet. Once this area is determined, the area in square feet is multiplied by the air velocity in feet per minute to determine the air volume through the transfer point.

Actual size of dust collector will vary, depending on measured air flow, type of material being collected, and material drop height.

Explosion-proof units are supplied with explosion-proof fan motor, spark-resistant fan, NEMA 9 control panel, anti-static filter media, and stainless steel inserts.

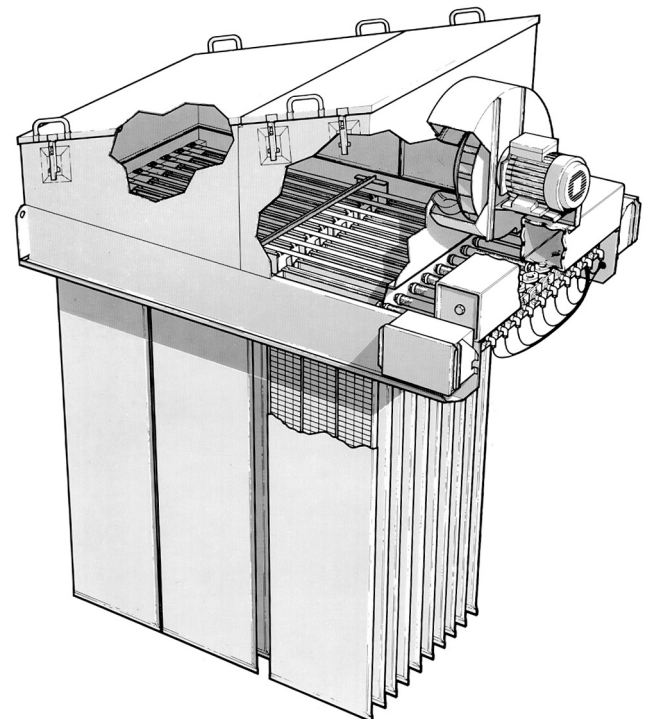
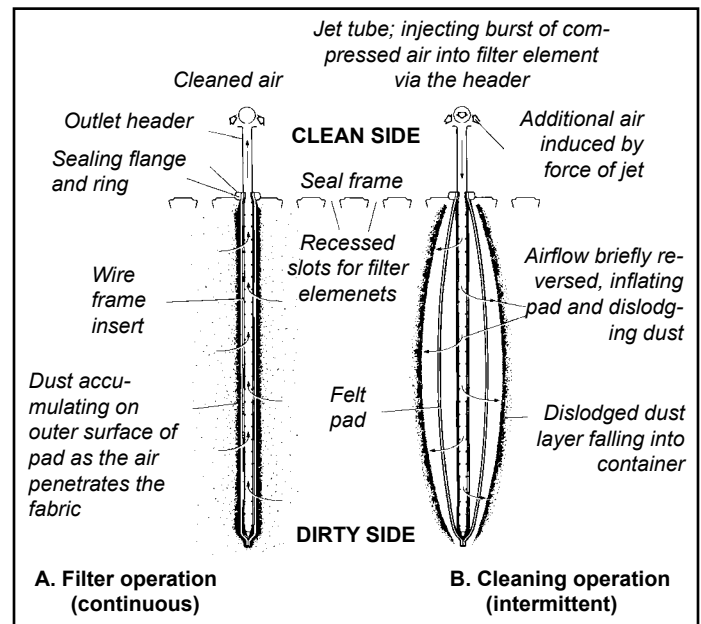

Martin Engineering Australia Pty Ltd.
102 Christensen Road South
Stapylton QLD 4207 - Australia
+61 1300 627 364
salesau@martin-eng.com | www.martin-eng.com.au

