

Martin® Air Cleaner with PowerCore® Filter



Overview

To overcome the maintenance problems and operating costs of centralized dust control systems, Martin Engineering recommends the use of the Martin® Air Cleaner with PowerCore® Filter on conveyor transfer points.

Rather than carry dust-laden air to a central collector, air cleaning systems filter the air inside the transfer point. There is no large fan, no ductwork, and no central bag house. Air cleaning filters are integrated into the transfer point enclosure, where they can easily return the filter dust as agglomerated material to the conveying system.

Air Cleaners can effectively handle the heavy concentrations of dust and volumes of air arising at belt conveyor transfer points.

High efficiency filters remove 99.99 percent of all particles larger than 0.5 micron.

Systems To Fit Your Application

Martin Engineering offers a full range of system sizes and filter materials to match application requirements.

Explosion-proof models are also available for use in explosive environments.

System Requirements

Compressed Air: 10.2 cfm @ 90-100 psi
 Electrical: 230/460V 3-Phase 60Hz
 (also available in 380V/50Hz)
 110V 5A supply for timer and solenoids
 Max. Operating Temperature: 150°F (66°C)

Replacement Filters

Standard: P/N 38432-FP
 Explosion-Proof: P/N 38432-FPE

The Martin® Air Cleaner is not designed for use with the following materials:

Gypsum	Soda Ash
Alumina	Hydrated Lime
Salts	Urea
Potash	Powder River Basin Coal

Benefits

Effective Dust Capture

The Martin® Air Cleaner with PowerCore® Filter is designed to remove 99.99 percent by weight of all dry particulate particles 0.5 micron and larger in size.

(This efficiency is based on a time-weighted average and assures the air cleaner will be installed, operated, and maintained in accordance with instructions.)

Continuous Operation

Automatic “reverse jet” cleaning sequence keeps filters working effectively with minimum compressed air.

Returns Product To The Process

Dust stays within the transfer point. Valuable material returns to the material handling system.

Low Energy Costs

Small, efficient integral fan operates only when conveyor runs.

Economical Installation

No ductwork to install, balance, or clean.

No Dust Disposal

No haulage costs for waste disposal. Valuable material returns to the process. No equipment needed to handle, package, or dispose of dust.

Compact Design

Small “footprint” reduces space requirements and installation cost.

Minimum Maintenance

“Clean side” access for inspection and filter changeout. No tools required to change filter.

Flexible Design

Stand-alone system or use to supplement existing central dust collector systems.

Easy Access

Large side or top door allows for easy access for inspection and filter changeout.

TECHNICAL DATA SHEET

Dimensions & Specifications

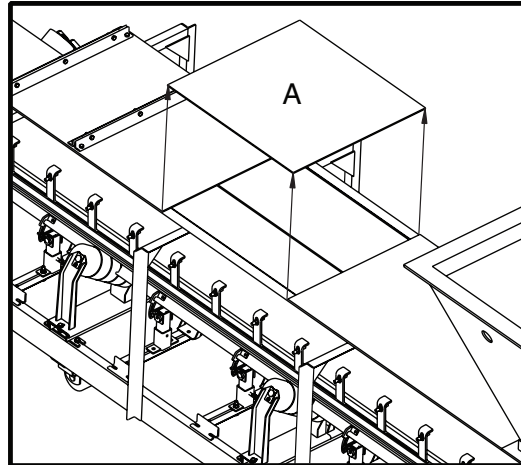

High End Air Flow* (cfm)	Air Cleaner P/N	Qty of Filters	Motor HP	Sound Level dbA @ 5 ft		Opening Size Required (A) in. (mm)
				Blower	Purge	
1000	DFAC-10XXXXXX	2	3	87	99	22.75 x 26.14 (578 x 664)
1500	DFAC-15XXXXXX	3	3	86	99	32.75 x 26.14 (832 x 664)
2000	DFAC-20XXXXXX	4	5	86	99	22.75 x 56.28 (578 x 1430)
3000	DFAC-30XXXXXX	6	5	88	99	32.75 x 56.28 (832 x 1430)

*If using with cement or PRB coal, contact Martin Engineering.

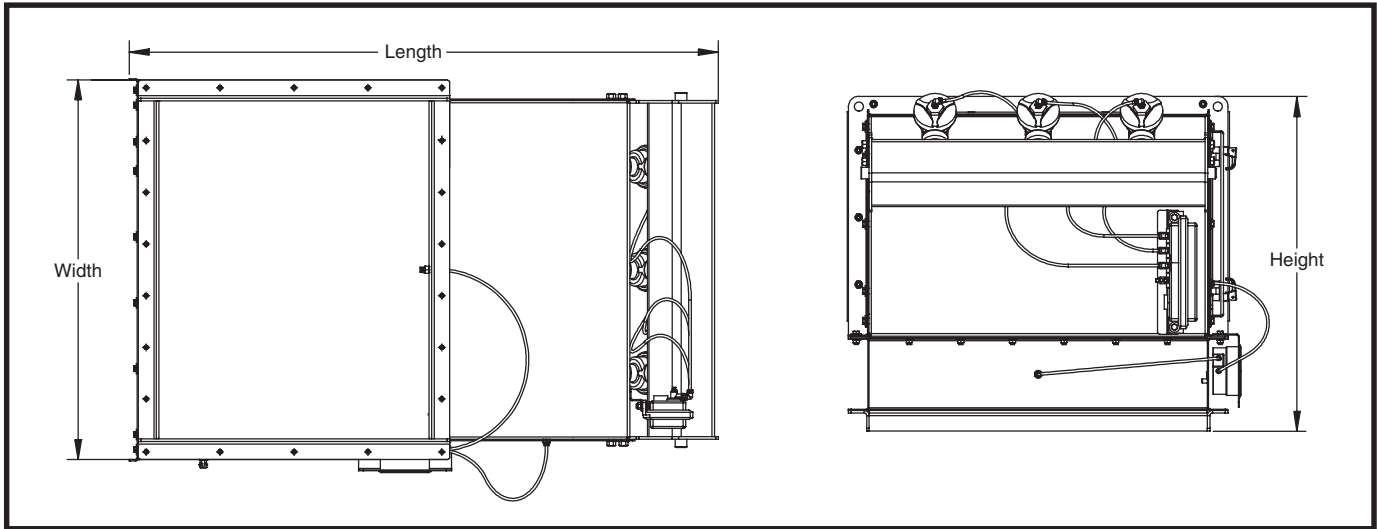

Air Cleaner P/N	Length* in. (mm)	Width* in. (mm)	Height* in. (mm)
DFAC-10XXXXXX	57 (145)	27 (69)	32 (81)
DFAC-15XXXXXX	57 (145)	37 (94)	32 (81)
DFAC-20XXXXXX	112 (285)	27 (69)	32 (81)
DFAC-30XXXXXX	112 (285)	37 (94)	32 (81)

*Without blower

Operation

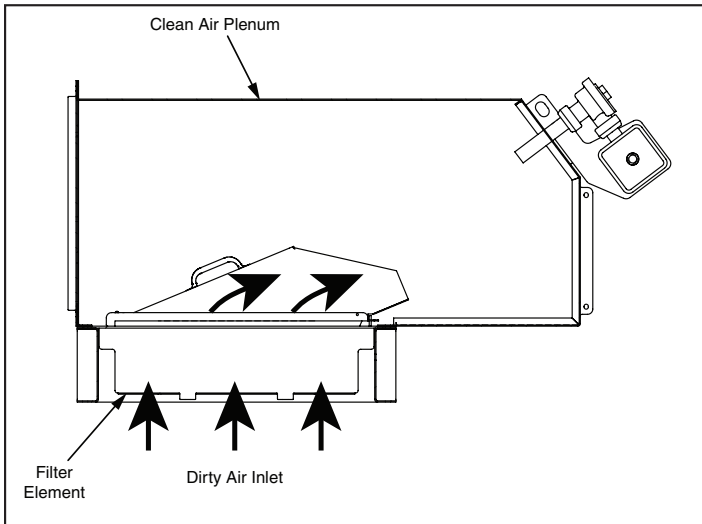

Standard Operation

An integral fan pulls dust-laden air through the filter elements. The air passes through the filter, leaving the particles on the filter element.

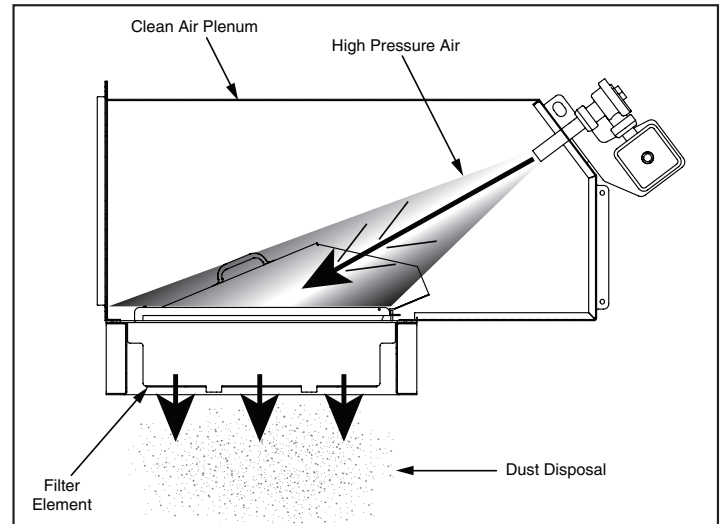

Self-Cleaning Operation

Each filter element is individually cleaned by a "reverse jet" of compressed air, which is injected into the filter element. This causes a momentary reversal of the air flow in the filter dislodging the dust cake back into the main material body. Filter cleaning happens without interrupting the process.

TECHNICAL DATA SHEET

NOMENCLATURE — DFAC-XX X X X X X X

1 2 3 4 5 6 7 8

1. Part Number Prefix
2. The first XX indicates high end airflow:
10 = 1000 CFM
15 = 1500 CFM
3. The next X indicates solenoid valve type:
S = Non-explosion proof service duty
E = Explosion proof service and NEMA 9 solenoid enclosure
H = Same as “E” with heaters in solenoid enclosure
4. The next X indicates right side item*:
F = Blower
D = Door
Ø = Cover Plate
5. The next X indicates top item:
F = Blower
Ø = Cover Plate
6. The next X indicates left side item**:
F = Blower
D = Door
Ø = Cover Plate
7. The next X indicates end item:
F = Blower
D = Door
Ø = Cover Plate
8. The next X indicates blower voltage/fan spool flange:
A = 380V 50 Hz 3 Phase
C = 220/480V 60 Hz 3 Phase
F = 575V 60 Hz 3 Phase
N07 = No Blower with 7.00 ID Fan Spool Flange
N08 = No Blower with 8.00 ID Fan Spool Flange
N13 = No Blower with 13.00 ID Fan Spool Flange
N14 = No Blower with 14.00 ID Fan Spool Flange
N16 = No Blower with 16.00 ID Fan Spool Flange
N18 = No Blower with 18.00 ID Fan Spool Flange

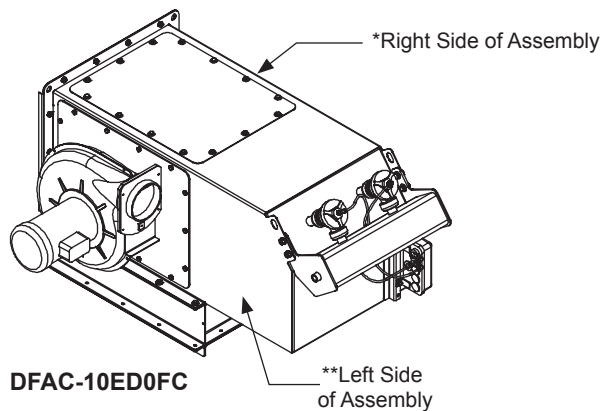

NOMENCLATURE — DFAC-XX X X X X X X

1 2 3 4 5 6 7

1. Part Number Prefix
2. The first XX indicates high end airflow:
20 = 2000 CFM
30 = 3000 CFM
3. The next X indicates solenoid valve type:
S = Non-explosion proof service duty
E = Explosion proof service and NEMA 9 solenoid enclosure
H = Same as “E” with heaters in solenoid enclosure
4. The next X indicates right side item*:
F = Blower
D = Door
Ø = Cover Plate
5. The next X indicates top item:
F = Blower
Ø = Cover Plate
6. The next X indicates left side item**:
F = Blower
D = Door
Ø = Cover Plate
7. The next X indicates blower voltage/fan spool flange:
A = 380V 50 Hz 3 Phase
C = 220/480V 60 Hz 3 Phase
F = 575V 60 Hz 3 Phase
N07 = No Blower with 7.00 ID Fan Spool Flange
N08 = No Blower with 8.00 ID Fan Spool Flange
N13 = No Blower with 13.00 ID Fan Spool Flange
N14 = No Blower with 14.00 ID Fan Spool Flange
N16 = No Blower with 16.00 ID Fan Spool Flange
N18 = No Blower with 18.00 ID Fan Spool Flange

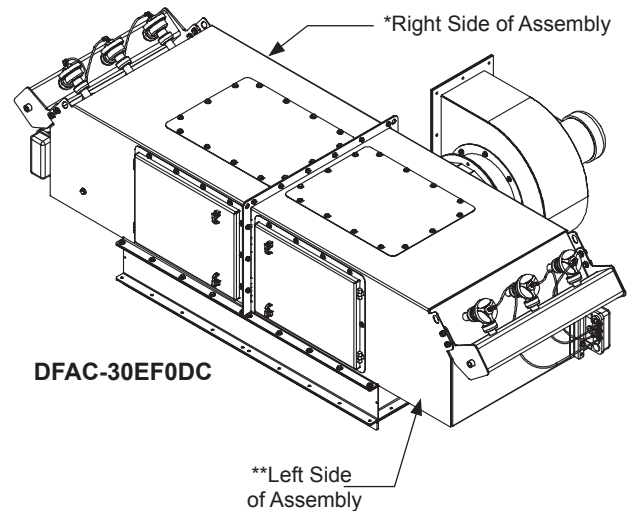

Martin Engineering Australia Pty Ltd.
102 Christensen Road South
Stapylton QLD 4207 - Australia
+61 1300 627 364
salesau@martin-eng.com | www.martin-eng.com.au

