

PART NUMBER	BELT WIDTH	DIMENSION "A" BLADE COVERAGE	DIMENSION "B" FRAME LENGTH
38556-54XX46XX	54.00 [1400-1600]	46.00 [1168]	84.00 [2134]
38556-54XX52XX	54.00 [1400-1600]	52.00 [1321]	84.00 [2134]
38556-60XX52XX	60.00 [1600-1800]	52.00 [1321]	90.00 [2286]
38556-60XX58XX	60.00 [1600-1800]	58.00 [1473]	90.00 [2286]
38556-66XX58XX	66.00 [1600-1800]	58.00 [1473]	96.00 [2438]
38556-66XX64XX	66.00 [1600-1800]	64.00 [1626]	96.00 [2438]
38556-72XX64XX	72.00 [1800-2000]	64.00 [1626]	102.00 [2591]
38556-72XX70XX	72.00 [1800-2000]	70.00 [1778]	102.00 [2591]
38556-78XX70XX	78.00 [1800-2000]	70.00 [1778]	108.00 [2743]
38556-78XX76XX	78.00 [1800-2000]	76.00 [1930]	108.00 [2743]
38556-84XX76XX	84.00 [2000-2200]	76.00 [1930]	114.00 [2896]
38556-84XX82XX	84.00 [2000-2200]	82.00 [2083]	114.00 [2896]

ASSEMBLY PART NO.	COLOR
38556-XXXXXX	ORANGE
38556-XXXXXBXX	BROWN
38556-XXXXXCLX	TAN
38556-XXXXXGRX	GREEN
38556-XXXXXNBX	NAVY BLUE

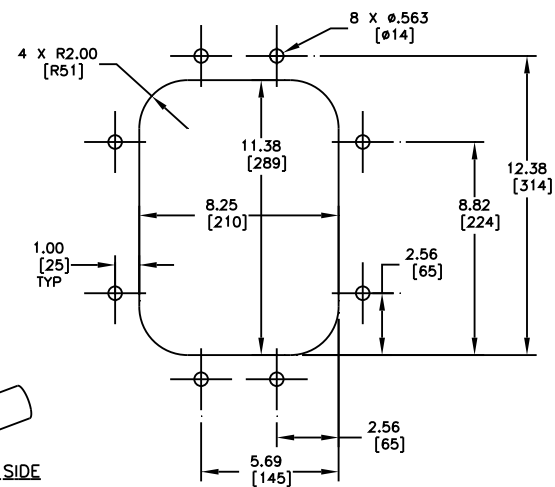
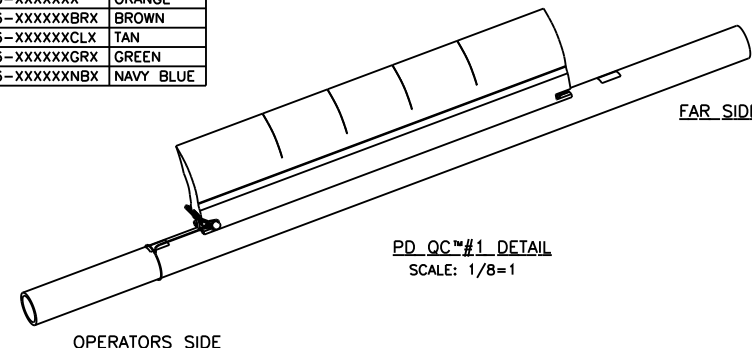

MOUNTING LOCATION CHART	
DIM. "C"	
HEAD PULLEY DIAMETER	DIM. "D"
12.00 [305] THRU 15.00 [381]	4.00 [102]
16.00 [406] AND OVER	3.50 [89]

\* INCLUDES BELT AND LAGGING

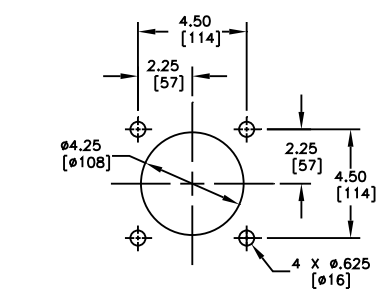

- NOTES:
- ALL DIMENSIONS ARE GIVEN IN INCHES [MM] AND ARE FOR REFERENCE ONLY.
  - IN THE 38556-XXXXXXX PART NUMBER THE FIRST TWO XX'S INDICATE THE BELT WIDTH. THE THIRD X INDICATES A BLADE WITH (0) OR WITHOUT (1) SLITS. THE NEXT X INDICATES A BLADE WITH (0) OR WITHOUT (1) SEGMENTS. THE NEXT TWO XX'S INDICATE BLADE COVERAGE. THE NEXT TWO XX'S INDICATE BLADE COLOR. THE LAST X INDICATES IF A TENSIONER IS INCLUDED.  
EXAMPLES:  
38556-541146BRT = 54" BELT WIDTH, 46" BROWN BLADE W/O SLITS AND SEGMENTS, WITH A TWIST TENSIONER.  
38556-541052 = 54" BELT WIDTH, 52" ORANGE BLADE W/O SLITS AND WITH SEGMENTS.  
38556-541152GRT = 54" BELT WIDTH, 52" GREEN BLADE W/O SLITS WITHOUT SEGMENTS, WITH A TWIST TENSIONER.
  - CUT MAINFRAME TO LENGTH, WITH BLADE CENTERED ON THE BELT MEASURE HOW FAR THE MAINFRAME IS OUTSIDE THE CHUTE WALL AND ADD 1.63 [41] MINIMUM TO CUT OFF.
  - THE PRE-CLEANER BLADE IS DESIGNED FOR HEAD PULLEY'S WITH A MINIMUM EFFECTIVE DIAMETER OF 12.00 [305].
  - CLEANER IS SHOWN IN RECOMMENDED WORKING POSITION.
  - WHERE EXTREME OR UNUSUAL CONDITIONS EXIST, OR SPECIAL MAINFRAME LENGTHS ARE REQUIRED CONTACT MARIN ENGINEERING.
  - TWIST TENSIONER MAY BE BOLTED OR WELDED IN PLACE, MARTIN ENGINEERING RECOMMENDS BOLTING WHEN APPLICABLE FOR EASIER MAINTENANCE AND ACCESSIBILITY.
  - REFER TO OPERATOR'S MANUAL M3798 FOR COMPLETE INSTALLATION INSTRUCTIONS.
  - FOR BELT WIDTHS 48.00 [1200-1400] AND UNDER, MARTIN ENGINEERING RECOMMENDS USING A TWIST TENSIONER (P/N 38554). SEE S50068-S.
  - CLEANER CAN BE LOCATED ANYWHERE ALONG THE ARC, AS LONG AS THE MAINFRAME IS OUT OF MATERIAL TRAJECTORY AND THE BLADE TIPS ARE BELOW THE HORIZONTAL CENTERLINE OF THE HEAD PULLEY.
  - THE PD QC #1 PRE-CLEANER BLADES ARE DESIGNED TO REMOVE HEAVY CARRYBACK ONLY. DO NOT OVERTENSION.
  - FOR SEVERE APPLICATIONS WELD THE MAINFRAME ADAPTER DIRECTLY TO MAINFRAME.
  - BLADE COVERAGE IS LESS THAN BELT WIDTH, DUE TO POSSIBLE MISTRACKING OR DAMAGED EDGES OF THE BELT.

ITEM	QTY.	DESCRIPTION	PART NUMBER
1	1	MARTIN PD QC #1 BLADE MAINFRAME ASM	38556-XXXXXXX
2	1	MARTIN TWIST™ DUAL TENSIONER ASM	38554-2
3	1	MARTIN LOW PROFILE STL DOOR 9X12	CYA-0912

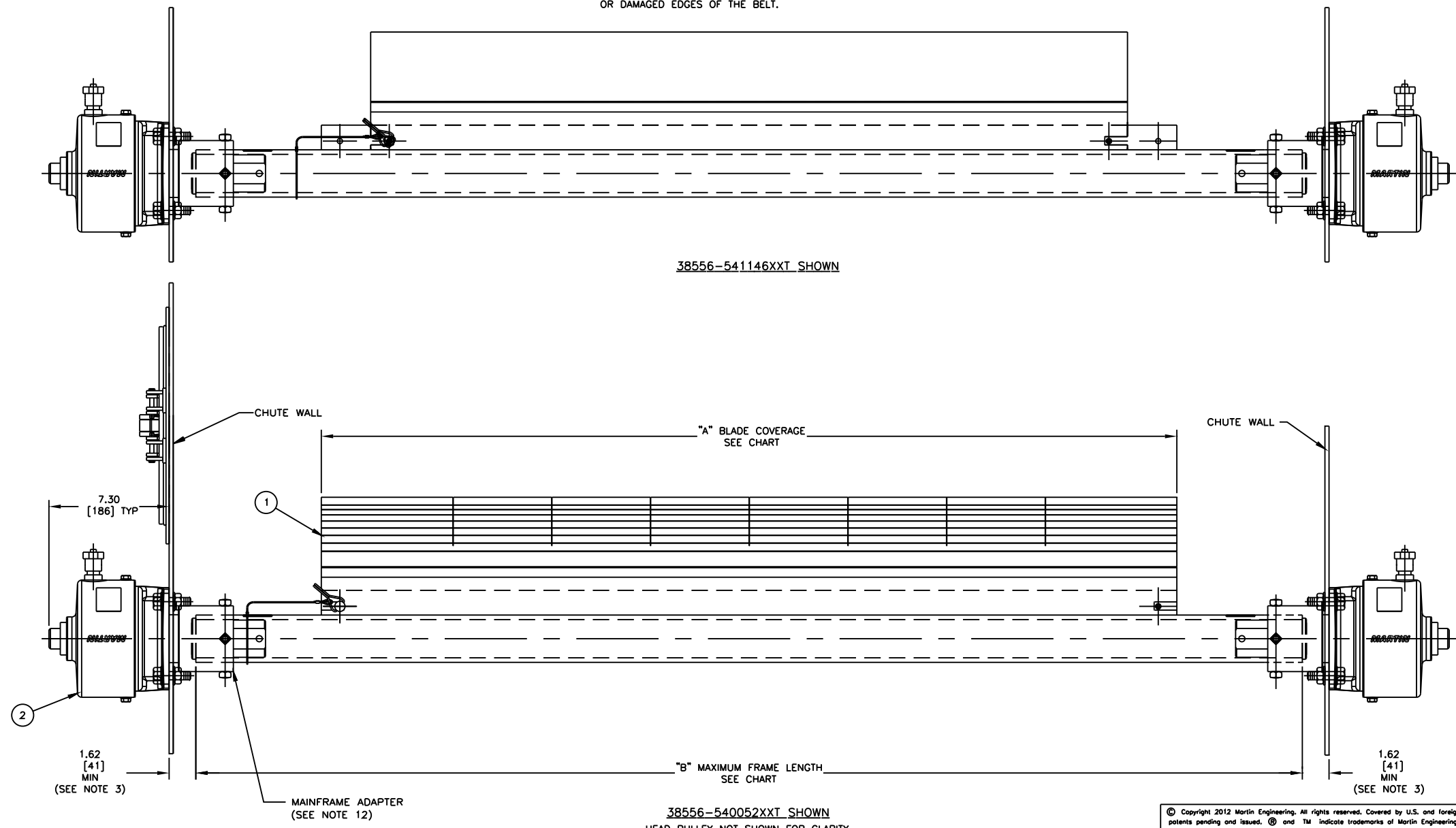
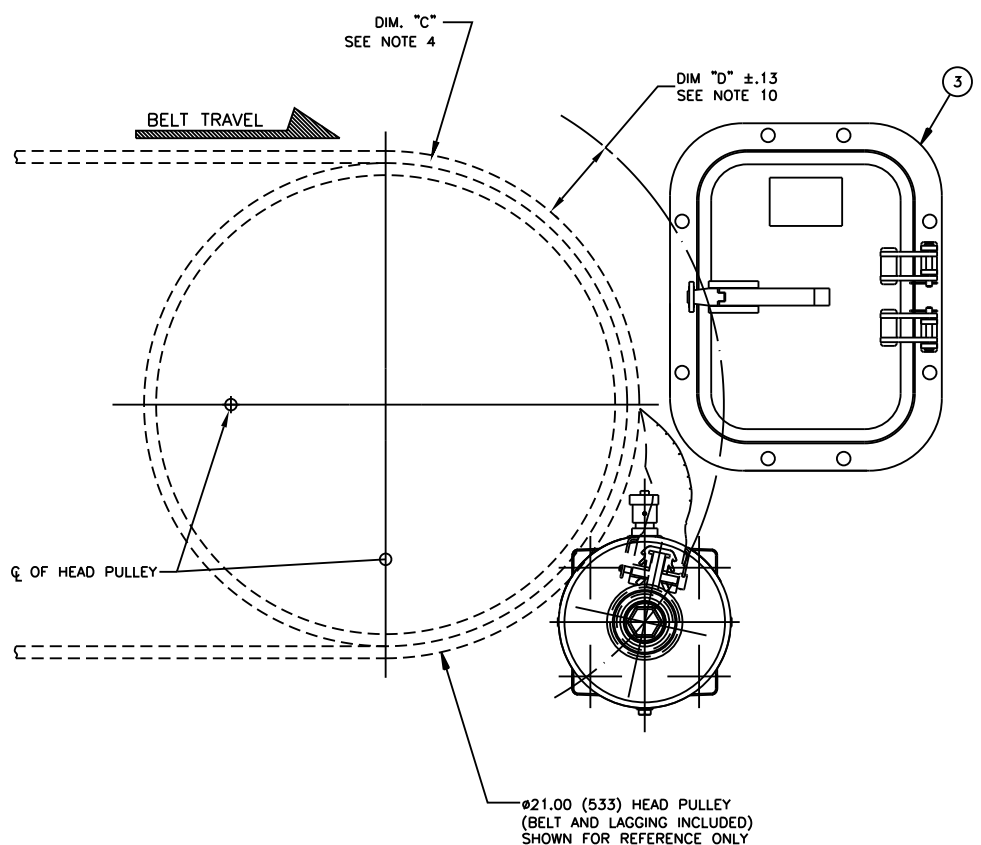

38556-540052XXT SHOWN  
HEAD PULLEY NOT SHOWN FOR CLARITY

© Copyright 2012 Martin Engineering. All rights reserved. Covered by U.S. and foreign patents pending and issued. ® and TM indicate trademarks of Martin Engineering.

MARTIN ENGINEERING-USA  
NEPONSET, IL USA

TITLE: MARTIN PERFORMANCE DUTY QC #1 ASM WITH TWIST™ TENSIONER ASM 9 X 12 STEEL DOOR

DRAWN RND: DATE 08/13/09  
CHECKED: DATE 08/19/09  
APPROVED: DATE 08/19/09  
SCALE: 1/4=1

SALES DRAWING: S50068-D  
PR11517

NO.	DESCRIPTION	ECN	DATE	BY
AutoCAD	REVISION			



