

***martin***®

# ***EVO***® ***High Speed Impact Cradle***

[Go to EVO® High Speed Impact Cradle web page](#)

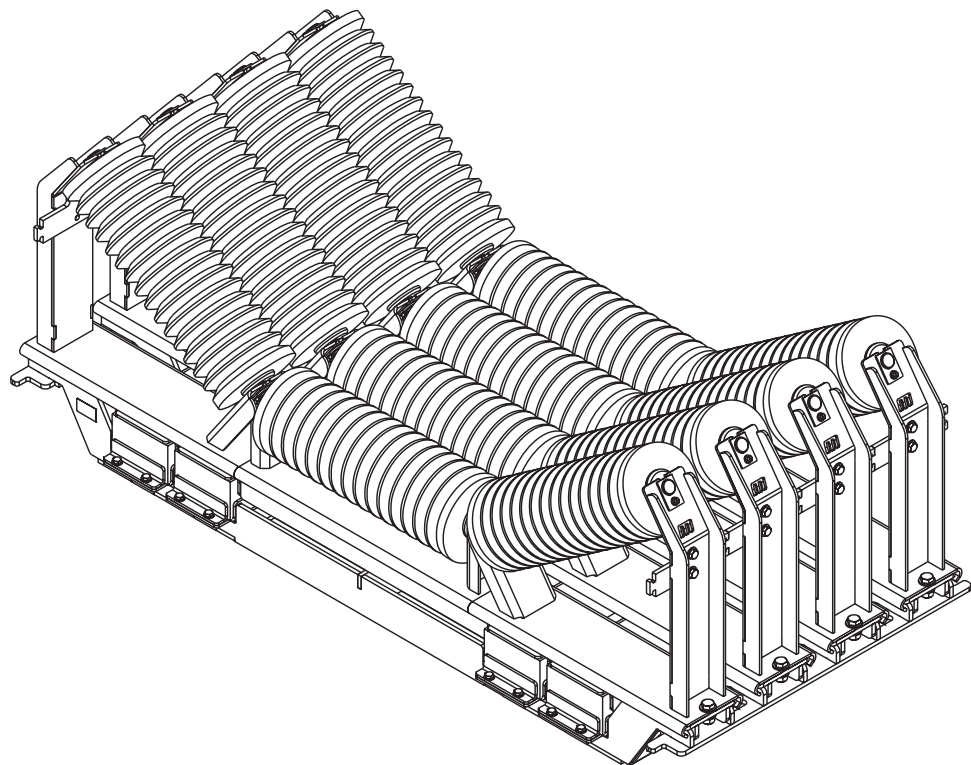

***Operator's Manual***  
***M3968***

# Important

MARTIN ENGINEERING HEREBY DISCLAIMS ANY LIABILITY FOR: DAMAGE DUE TO CONTAMINATION OF THE MATERIAL; USER'S FAILURE TO INSPECT, MAINTAIN AND TAKE REASONABLE CARE OF THE EQUIPMENT; INJURIES OR DAMAGE RESULTING FROM USE OR APPLICATION OF THIS PRODUCT CONTRARY TO INSTRUCTIONS AND SPECIFICATIONS CONTAINED HEREIN. MARTIN ENGINEERING'S LIABILITY SHALL BE LIMITED TO REPAIR OR REPLACEMENT OF EQUIPMENT SHOWN TO BE DEFECTIVE.

Observe all safety rules given herein along with owner and Government standards and regulations. Know and understand lockout/tagout procedures as defined by American National Standards Institute (ANSI) z244.1-1982, *American National Standard for Personnel Protection - Lockout/Tagout of Energy Sources - Minimum Safety Requirements* and Occupational Safety and Health Administration (OSHA) Federal Register, Part IV, 29 CFR Part 1910, *Control of Hazardous Energy Source (Lockout/Tagout); Final Rule*.

The following symbols may be used in this manual:



**Danger:** Immediate hazards that will result in severe personal injury or death.



**Warning:** Hazards or unsafe practices that could result in personal injury.



**Caution:** Hazards or unsafe practices that could result in product or property damages.



**Important:** Instructions that must be followed to ensure proper installation/operation of equipment.



**Note:** General statements to assist the reader.

# Table of Contents

---

<b>Section</b>	<b>Page</b>
List of Figures .....	ii
List of Tables .....	ii
Introduction .....	1
General .....	1
References .....	1
Materials Required .....	1
Safety .....	1
Before Installing Impact Cradle .....	3
Installing Impact Cradle .....	4
Installing Impact Cradle .....	5
After Installing Impact Cradle .....	8
Maintenance .....	9
Installation Checklist .....	10
Part Numbers .....	11

## **List of Figures**

---

<b>Figure</b>	<b>Title</b>	<b>Page</b>
1	Measuring for Impact Cradle .....	4
2	EVO <sup>®</sup> High Speed Impact Cradle, P/N HSRCXXP-XXXXX .....	12

## **List of Tables**

---

<b>Table</b>	<b>Title</b>	<b>Page</b>
I	EVO <sup>®</sup> High Speed Impact Cradle Part Numbers .....	14

# Introduction

---

## General

Designed and engineered for high speed / high tonnage belts, EVO<sup>®</sup> High Speed Impact Cradles provide belt support in transfer points where belt speeds exceed the operating limits of ordinary impact bar belt support cradles.

## References

The following documents are referenced in this manual:

- American National Standards Institute (ANSI) z244.1-1982, *American National Standard for Personnel Protection - Lockout/Tagout of Energy Sources - Minimum Safety Requirements*, American National Standards Institute, Inc., 1430 Broadway, New York, NY 10018.
- Federal Register, Volume 54, Number 169, Part IV, 29 CFR Part 1910, *Control of Hazardous Energy Source (Lockout/Tagout); Final Rule*, Department of Labor, Occupational Safety and Health Administration (OSHA), 32nd Floor, Room 3244, 230 South Dearborn Street, Chicago, IL 60604.

## Materials Required

Only standard hand tools are required to install and service this equipment.

## Safety

All safety rules defined in the above documents and all owner/employer safety rules must be strictly followed when working on the impact cradle.



### **⚠ DANGER**

**Do not touch or go near the conveyor belt or conveyor accessories when the belt is running. Your body or clothing can get caught and you can be pulled into the conveyor, resulting in severe injury or death.**



### **⚠ DANGER**

**Before installing, servicing, or adjusting conveyor equipment, turn off and lockout / tagout / blockout / testout all energy sources to the conveyor and conveyor accessories according to ANSI standards. Failure to do so could result in serious injury or death.**



### **⚠ DANGER**

**If this equipment will be installed in an enclosed area, test the gas level or dust content before using a cutting torch or welding. Using a torch or welding in an area with gas or dust may cause an explosion resulting in serious injury or death.**



**⚠ WARNING**

Before using a cutting torch or welding the chute wall, cover the conveyor belt with a fire retardant cover. Failure to do so can allow the belt to catch fire.

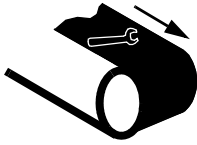

**⚠ WARNING**

Remove all tools from the installation area and conveyor belt before turning on the conveyor. Failure to do so can cause serious injury to personnel or damage to the belt and conveyor.



**⚠ WARNING**

Impact cradle components can be heavy and may require two people to lift. Attempting to lift the components without assistance could result in injury.

# Before Installing Impact Cradle

1. Inspect shipping container for damage. Report damage to delivery service immediately and fill out delivery service's claim form. Keep any damaged goods subject to examination.
2. Remove impact cradle from shipping container. Equipment in container should include the following:
  - EVO<sup>®</sup> High Speed Impact Cradle Assembly
3. If anything is missing or damaged, contact Martin Engineering or a representative.
4. Make sure belt is centered on conveyor.



## **⚠ DANGER**

**Before installing, servicing, or adjusting conveyor equipment, turn off and lockout / tagout / blockout / testout all energy sources to the conveyor and conveyor accessories according to ANSI standards. Failure to do so could result in serious injury or death.**

5. Turn off and lockout / tagout / blockout / testout energy source according to ANSI standards (see "References").

## **⚠ DANGER**

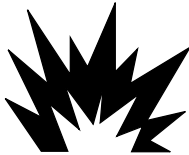

**If this equipment will be installed in an enclosed area, test the gas level or dust content before using a cutting torch or welding. Using a torch or welding in an area with gas or dust may cause an explosion resulting in serious injury or death. Follow local confined space procedures.**

6. If using a cutting torch or welding, test atmosphere for gas level or dust content. Cover conveyor belt with fire retardant cover.
7. Remove any unnecessary idlers.

# Installing Impact Cradle

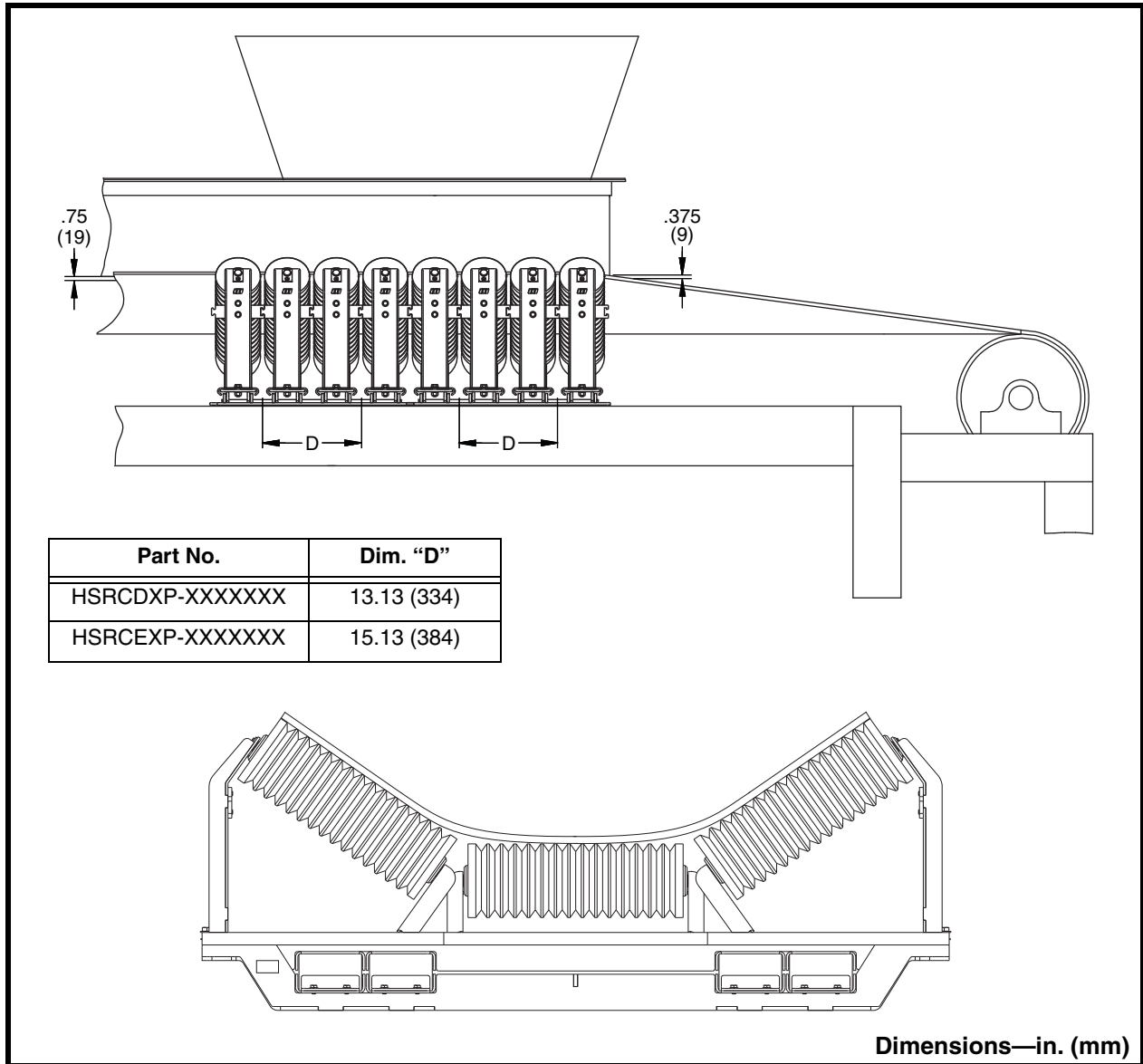
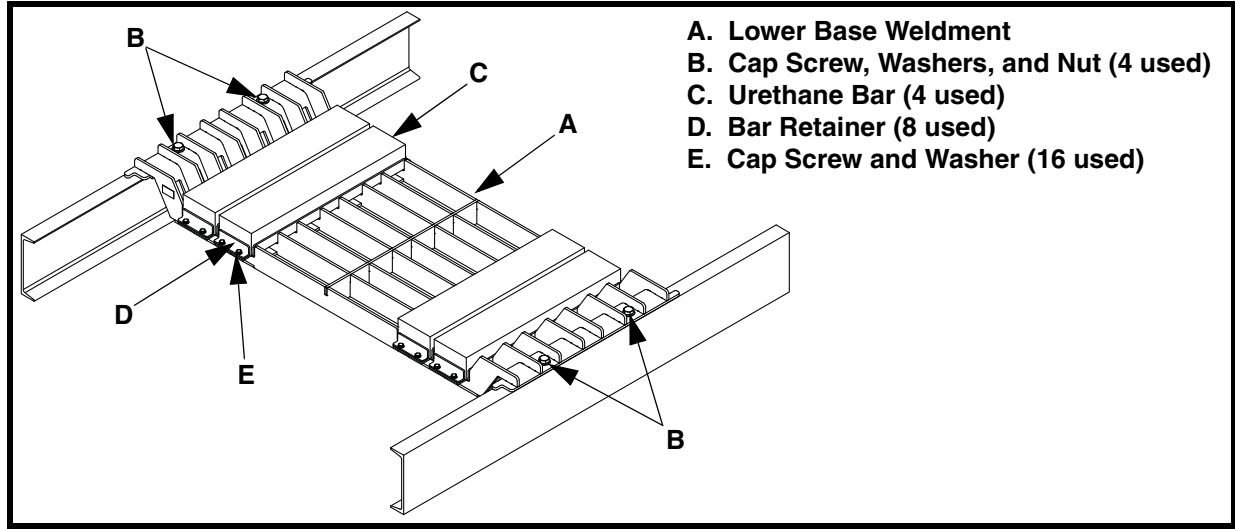

**Figure 1. Measuring for Impact Cradle**

1. See Figure 1. The distance between top of belt and bottom of wear liners must increase over length of transfer point. If necessary, modify chute walls and/or wear liners.
2. Mark center of loading point on stringer; both sides of belt.
3. Make sure belt will contact center roll.
4. Make sure clearance between belt and wing section is 1/2 in. (13 mm) where wing section meets center section and tapers to no clearance between belt and wing section at outside edge.



## Installing Impact Cradle



1. Mark location of lower base weldment (A) on stringers. See Figure 1 for mounting dimensions.
2. Position lower base weldment on stringers.
3. Make sure lower base weldment is perpendicular to belt and centered below belt, or rolls will wear unevenly and maintenance will be difficult.

### NOTE

**Martin Engineering recommends bolting rather than welding cross supports to stringers for easier accessibility and maintenance.**

4. Bolt or weld lower base weldment to stringers as follows:
  - a. If bolting, drill or cut 5/8-in. holes in stringers through mounting holes in feet of lower base weldment. Install cap screw, flat washer, compression washer, and nut (B) in each hole to secure lower base weldment to stringers.
  - b. If welding, clean stringer of rust and dirt. Then stitch weld lower base weldment to stringers.
5. Install urethane bars (C) and secure using bar retainers (D) and cap screws and compression washers (E).

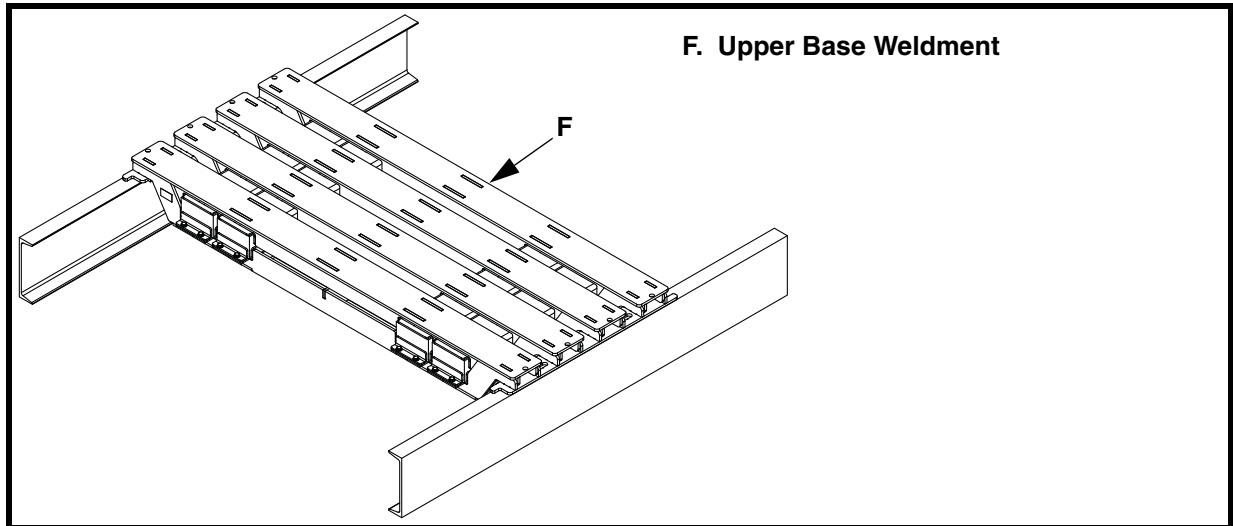

6. Install upper base weldment (F) onto lower base weldment.

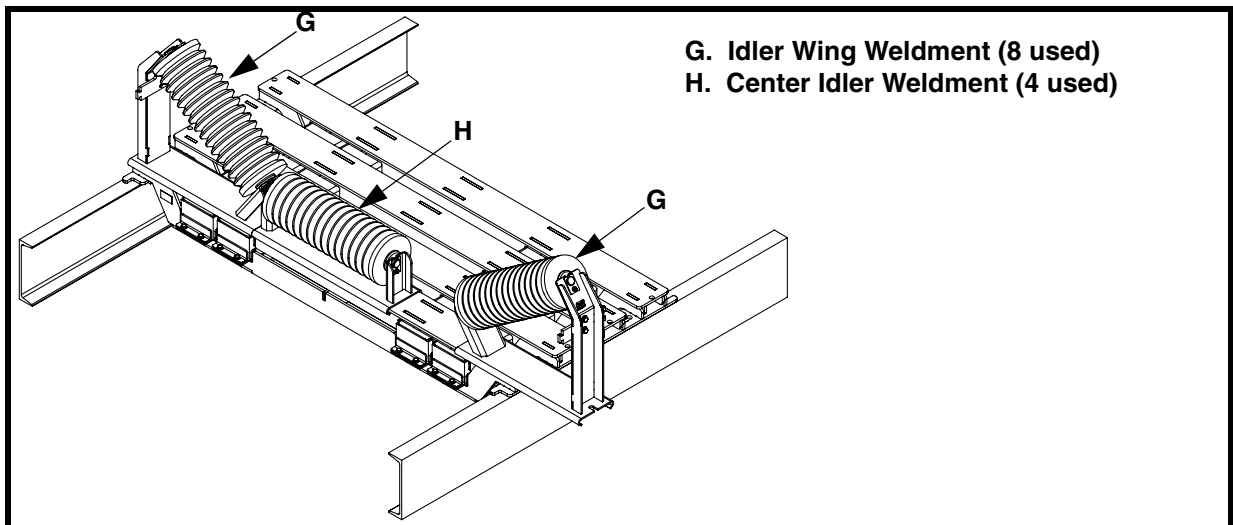

7. Slide center idler weldments (H) onto base weldment.
8. Make sure belt will contact center rolls.
9. Slide idler wing weldments (G) onto each side of base weldment.

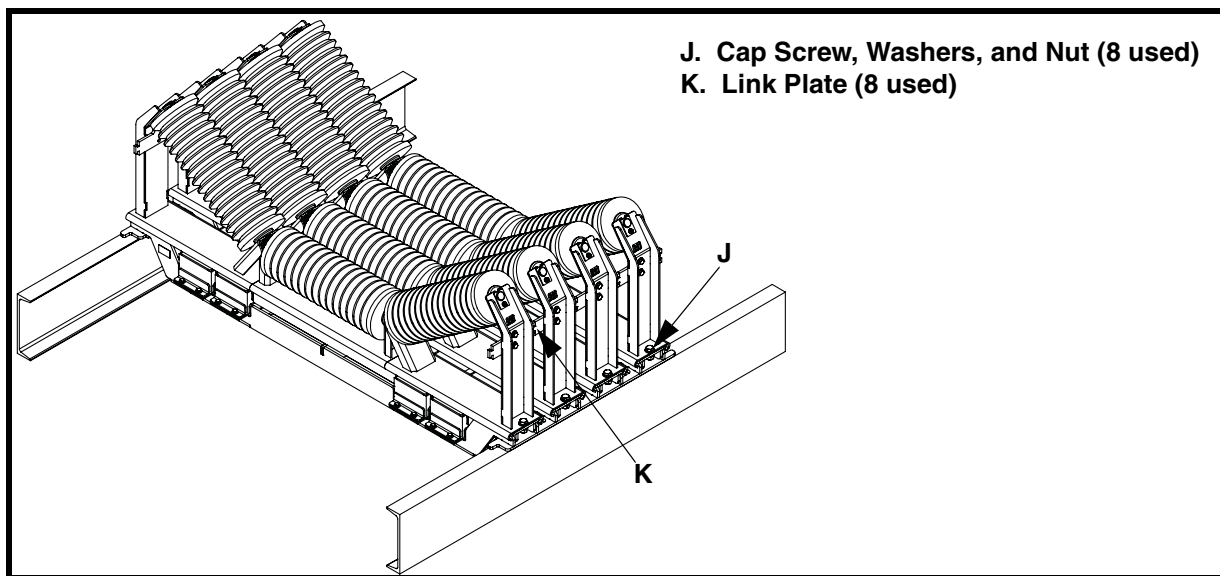

10. Install cap screw, washers, and nut (J) on each wing idler, but do not tighten.
11. Align link plates (K) on each wing idler.
12. Center rolls on belt.
13. Tighten cap screw, washers, and nut (J) on each wing idler.

## After Installing Impact Cradle

### IMPORTANT

Read entire section before beginning work.

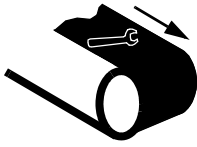

### ⚠ WARNING

Failure to remove tools from installation area and conveyor belt before turning on energy source can cause serious injury to personnel and damage to belt.

1. Remove all tools and fire retardant cover from installation area and conveyor belt.



### ⚠ DANGER

Do not touch or go near conveyor belt or conveyor accessories when conveyor belt is running. Body or clothing can get caught and pull body into conveyor belt, causing severe injury or death.

2. Turn on conveyor belt.



### ⚠ WARNING

Before adjusting impact cradle, turn off and lockout / tagout / blockout / testout all energy sources to conveyor belt and conveyor accessories.

3. After 1 hour of operation, turn off and lockout / tagout / blockout / testout energy source according to ANSI standards (see “References”).
4. Make sure all fasteners are tight. Tighten if necessary.
5. If excessive wear, uneven wear, or some other problem exists, see “Troubleshooting/ Installation Checklist.”

## IMPORTANT

Read entire section before beginning work.



## WARNING

Before servicing impact cradle, turn off and lockout / tagout / blockout / testout all energy sources to conveyor belt and conveyor accessories.

1. Turn off and lockout / tagout / blockout / testout energy source according to ANSI standards (see “References”).
2. Make sure all fasteners are tight. Tighten if necessary.
3. Check rolls for wear. If necessary, replace rolls as follows:
  - a. Remove cap screws, washers, and nuts holding wing weldment to base weldment.
  - b. Remove wing weldments and center weldment.
  - c. Replace impact rolls on each weldment as follows:
    - (1) Remove cap screw and tie tab.
    - (2) Replace worn rolls and reinstall in reverse order.
  - d. Install center weldment and wing weldments.
  - e. Install cap screws, washers, and nuts holding wing weldment to base weldment.
4. Inspect impact cradle for cracks or fatigue. Weld or strengthen structure as necessary.
5. Wipe warning labels clean. If labels are not readable, contact Martin Engineering or a representative for replacements.

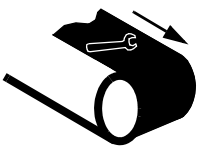

## WARNING

Failure to remove tools from maintenance area and conveyor belt before turning on energy source can cause serious injury to personnel and damage to belt.

6. Remove all tools from maintenance area.

## DANGER

Do not touch or go near conveyor belt or conveyor accessories when conveyor belt is running. Body or clothing can get caught and pull body into conveyor belt, causing severe injury or death.



7. Start conveyor belt.

# Installation Checklist

---

***Installation Checklist***

If you are experiencing problems with EVO<sup>®</sup> High Speed Impact Cradle, check for the following:

Installation Checklist
Chute walls and/or wear liners are 3/8 in. above belt at tail and 3/4 in. above belt at head.
Impact cradle aligns with center of loading point.
Center impact rolls are centered below belt.
Make sure belt is contacting center rolls.

## Part Numbers

---

This section provides product names and corresponding part numbers for EVO<sup>®</sup> High Speed Impact Cradles. Please reference part numbers when ordering parts.

***EVO<sup>®</sup>  
High Speed  
Impact Cradle***

**EVO<sup>®</sup> High Speed Impact Cradle:** P/N HSRCXXP-XXXXX

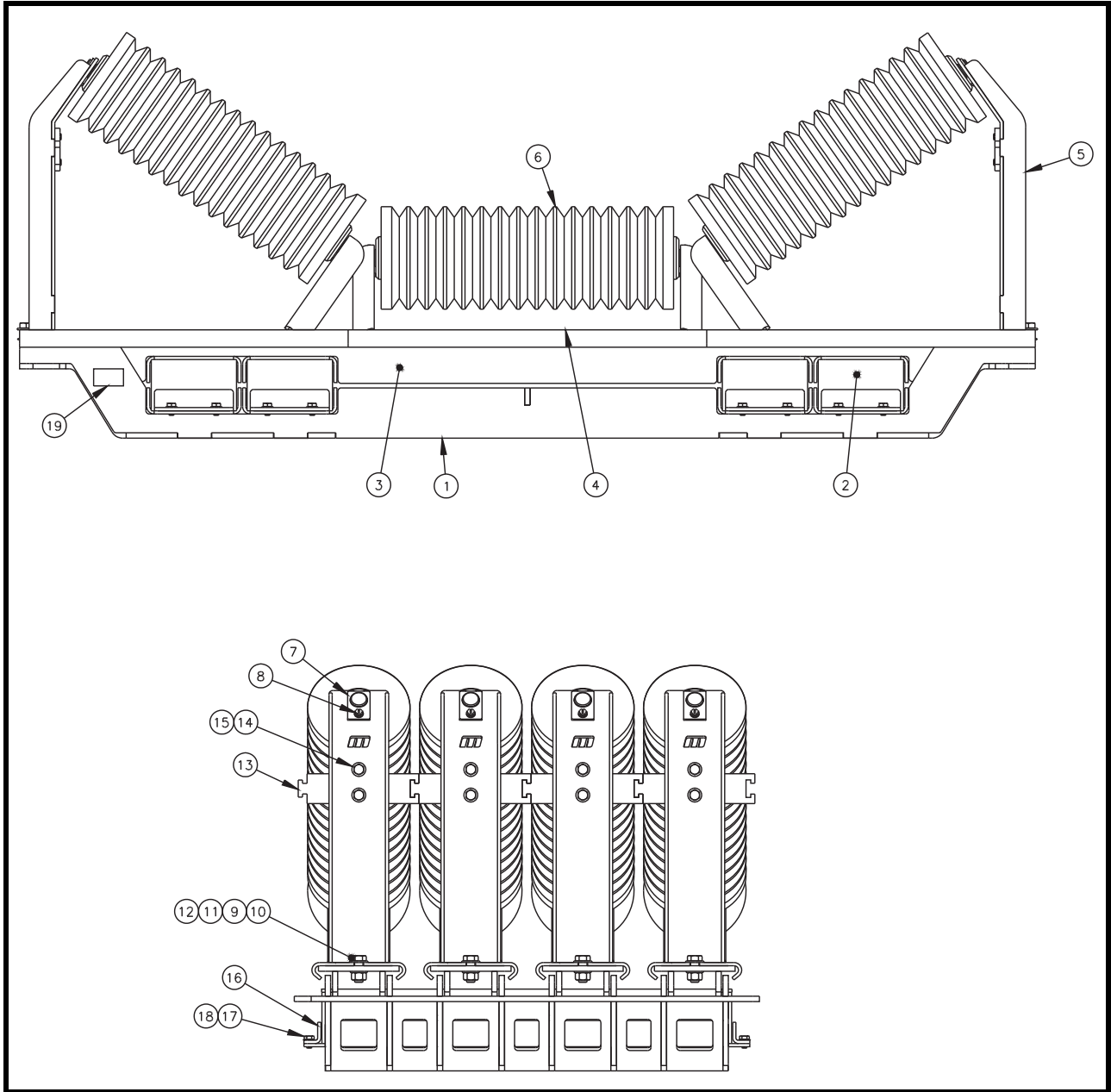

Figure 2. EVO<sup>®</sup> High Speed Impact Cradle, P/N HSRCXXP-XXXXX



Item	Description	Part No.	Qty
1	Lower Base Weldment	HSRC-BWL-XXXX*	1
2	Impact Bar	HSRC-IB-1001	4
3	Upper Base Weldment	HSRC-BWU-XXXX*	1
4	TMI Center Weldment	TMI-CW-XXXP**	4
5	TMI Wing Weldment	TMI-WW-XXXXXXP***	8
6	Impact Roll	Table I	12
7	Tie Tab	Table I	24
8	Screw Tapping HWH 1/4-20NC x 3/8 Type C ZP	38608	24
9	Washer Flat 1/2 narrow ZP	31010	8
10	Screw HHC 1/2-13NC x 1-1/4 ZP	13835	8
11	Washer Compression 1/2	11750	8
12	Nut Hex 1/2-13NC ZP	11771	8
13	Link Plate	Table I	8
14	Washer Compression 3/8	11747	16
15	Screw HHC 3/8-16NC x 5/8 ZP	12379	16
16	Impact Bar Retainer	Table I	8
17	Screw HHC 5/16-18NC x 1/2 ZP	19134	16
18	Washer Compression 5/16	11452	16
19	Label Martin Product	32238	2
20 (NS)	Washer Flat 5/8 Narrow ZP	16814	4
21 (NS)	Washer Compression 5/8 ZP	11752	4
22 (NS)	Screw HHC 5/8-11NC x 2-3/4 ZP	23532	4
23 (NS)	Nut Hex 5/8-11NC ZP	11772	4
24 (NS)	Operator's Manual	M3968	1

NS = Not Shown

### Figure 2. EVO® High Speed Impact Cradle, P/N HSRCXXP-XXXXX

HSRC indicates EVO® High Speed Impact Cradle. First X indicates CEMA Class (D or E). Next X indicates Roll Diameter (5, 6, or 7). Next X indicates Roll Manufacturer (P) for PPI. Next X indicates Belt Width (CEMA D is 24–72 and CEMA E is 36–72). Next X indicates Trough Angle (20 or 35 degrees). Next X indicates Standard (S) or Wide (W) base stringer.

\*First X indicates CEMA Class (D or E). Next XX indicates Belt Width. Last X indicates Standard (S) or Wide (W) base stringer.

\*\*First X indicates CEMA Class (D or E). Next XX indicates Belt Width.

\*\*\*First X indicates CEMA Class (D or E). Next XX indicates Belt Width. Next XX indicates Trough Angle. Last X indicates Standard (S) or Wide (W) base stringer.

**Table I. EVO<sup>®</sup> High Speed Impact Cradle Part Numbers**

<b>Part No.</b>	<b>P/N Item 6</b>
HSRCD5P-XXXXXXX	TMIRD5-XXIP
HSRCD6P-XXXXXXX	TMIRD6-XXIP
HSRCE6P-XXXXXXX	TMIRE6-XXIP
HSRCE7P-XXXXXXX	TMIRE7-XXIP

<b>Part No.</b>	<b>P/N Item 7</b>	<b>P/N Item 13</b>	<b>P/N Item 16</b>
HSRCDXP-XXXXXXX	TMI-TT-100P	HSRC-LP-D	HSRC-IBR-D
HSRCEXP-XXXXXXX	TMI-TT138P	HSRC-LP-E	HSRC-IBR-E

# **Appendix**

## **EVO<sup>®</sup> High Speed Impact Cradle Dimensions**

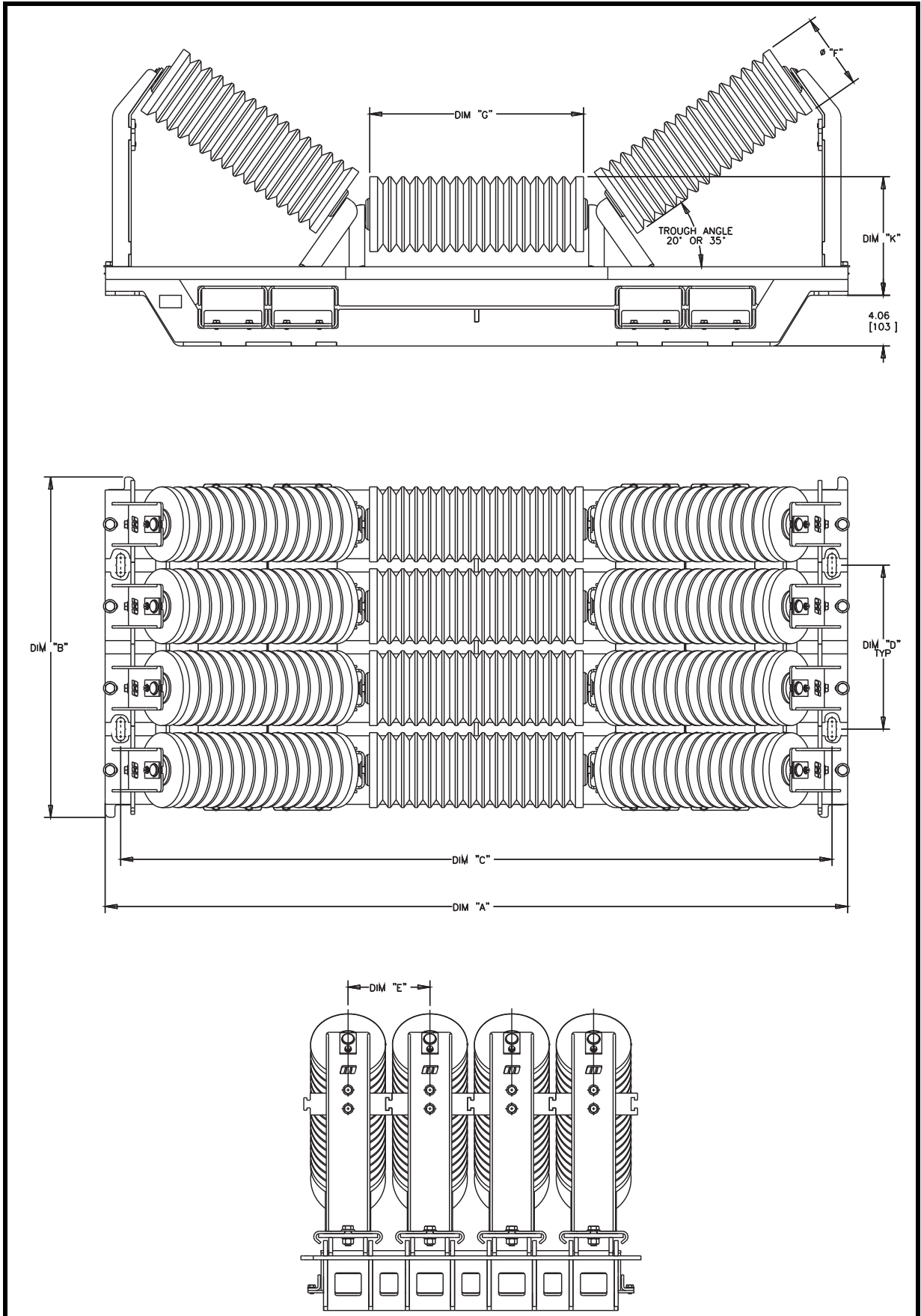

## EVO® High Speed Impact Cradle Dimensions

Part No.	Dim. "A"	Dim. "C"	Dim. "K"*	Dim. "G"
HSRCDXP-24XXS	Equals belt width plus 9.	Equals belt width plus 11.50.	9.00	8.44
HSRCDXP-30XXS			9.00	10.63
HSRCDXP-36XXS			9.00	12.75
HSRCDXP-42XXS			9.50	14.94
HSRCDXP-48XXS			9.50	17.13
HSRCDXP-54XXS			9.75	19.25
HSRCDXP-60XXS			9.75	21.25
HSRCDXP-72XXS			10.00	25.50

HSRCDXP-24XXW	Equals belt width plus 15.	Equals belt width plus 17.50.	9.00	8.44
HSRCDXP-30XXW			9.00	10.63
HSRCDXP-36XXW			9.00	12.75
HSRCDXP-42XXW			9.50	14.94
HSRCDXP-48XXW			9.50	17.13
HSRCDXP-54XXW			9.75	19.25
HSRCDXP-60XXW			9.75	21.25
HSRCDXP-72XXW			10.00	25.50

HSRCEXP-36XXS	Equals belt width plus 9.	Equals belt width plus 12.00.	10.75	13.00
HSRCEXP-42XXS			10.75	15.00
HSRCEXP-48XXS			10.75	17.75
HSRCEXP-54XXS			10.75	19.75
HSRCEXP-60XXS			10.75	21.75
HSRCEXP-72XXS			11.50	25.75

HSRCEXP-36XXW	Equals belt width plus 15.	Equals belt width plus 18.00.	10.75	13.00
HSRCEXP-42XXW			10.75	15.00
HSRCEXP-48XXW			10.75	17.75
HSRCEXP-54XXW			10.75	19.75
HSRCEXP-60XXW			10.75	21.75
HSRCEXP-72XXW			11.50	25.75

\*Dimension "K" is shown for 6 inch rolls. Subtract .50 for 5 inch rolls. Add .50 for 7 inch rolls.

<b>Part No.</b>	<b>Dim. "F"</b>
HSRCD5P-XXXXXXX	5.00 (127)
HSRCD6P-XXXXXXX	6.00 (152)
HSRCE6P-XXXXXXX	6.00 (152)
HSRCE7P-XXXXXXX	7.00 (178)

<b>Part No.</b>	<b>Dim. "B"</b>	<b>Dim. "D"</b>	<b>Dim. "E"</b>
HSRCDXP-XXXXXXX	27.25 (692)	13.13 (334)	6.56 (167)
HSRCEXP-XXXXXXX	31.25 (794)	15.13 (384)	7.56 (191)

*Any product, process, or technology described here may be the subject of intellectual property rights reserved by Martin Engineering Company. Trademarks or service marks designated with the ® symbol are registered with the U.S. Patent and Trademark Office and may be proprietary in one or more countries or regions. Other trademarks and service marks belonging to Martin Engineering Company in the United States and/or other countries or regions may be designated with the “TM” and “SM” symbols. Brands, trademarks, and names of other parties, who may or may not be affiliated with, connected to, or endorsed by Martin Engineering Company, are identified wherever possible. Additional information regarding Martin Engineering Company’s intellectual property can be obtained at [www.martin-eng.com/trademarks](http://www.martin-eng.com/trademarks).*

# **Problem Solved™** ***GUARANTEED!***

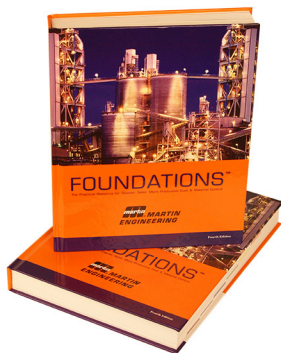

*For nearly 20 years, Martin Engineering's Foundations™ Books have taught industry personnel to operate and maintain clean and safe belt conveyors. The Foundations™ Book, fourth edition, focuses on improving belt conveyors by controlling fugitive material. "The Practical Resource for Total Dust and Material Control," is a 576-page hard cover volume that provides information of value to industries where the efficient handling of bulk materials is a key to productivity and profitability.*

*Expanding upon the book, our Foundations™ Training Program addresses the design and development of more productive belt conveyors, and is offered in three customizable seminars. Attendees gain a better understanding of conveyor safety and performance, helping to justify upgrade investments and increase profitability.*



## **Martin Engineering USA**

One Martin Place  
Neponset, IL 61345-9766 USA  
800 544 2947 or 309 852 2384  
Fax 800 814 1553  
[www.martin-eng.com](http://www.martin-eng.com)

**COMPANY WITH  
QUALITY SYSTEM  
CERTIFIED BY DNV  
= ISO 9001:2008 =**