

martin®

EVO®
Combination Cradle

[Go to EVO® Combination Cradle web page](#)



Operator's Manual
M3896

Important

MARTIN ENGINEERING HEREBY DISCLAIMS ANY LIABILITY FOR: DAMAGE DUE TO CONTAMINATION OF THE MATERIAL; USER'S FAILURE TO INSPECT, MAINTAIN AND TAKE REASONABLE CARE OF THE EQUIPMENT; INJURIES OR DAMAGE RESULTING FROM USE OR APPLICATION OF THIS PRODUCT CONTRARY TO INSTRUCTIONS AND SPECIFICATIONS CONTAINED HEREIN. MARTIN ENGINEERING'S LIABILITY SHALL BE LIMITED TO REPAIR OR REPLACEMENT OF EQUIPMENT SHOWN TO BE DEFECTIVE.

Observe all safety rules given herein along with owner and Government standards and regulations. Know and understand lockout/tagout procedures as defined by American National Standards Institute (ANSI) z244.1-1982, *American National Standard for Personnel Protection - Lockout/Tagout of Energy Sources - Minimum Safety Requirements* and Occupational Safety and Health Administration (OSHA) Federal Register, Part IV, 29 CFR Part 1910, *Control of Hazardous Energy Source (Lockout/Tagout); Final Rule*.

The following symbols may be used in this manual:



Danger: Immediate hazards that will result in severe personal injury or death.



Warning: Hazards or unsafe practices that could result in personal injury.



Caution: Hazards or unsafe practices that could result in product or property damages.



Important: Instructions that must be followed to ensure proper installation/operation of equipment.



Note: General statements to assist the reader.

Table of Contents

Section	Page
List of Figures	ii
List of Tables	ii
Introduction	1
General	1
References	1
Combination Cradle Materials	1
Safety	1
Materials Required	1
Before Installing Combination Cradle	2
Installing Combination Cradle	3
Installation on EVO [®] Stringer	5
Installation on Standard Stringer	6
Installing Impact Bars	7
After Installing Combination Cradle	8
Maintenance	9
Troubleshooting/Installation Checklist	11
Part Numbers	12

List of Figures

Figure	Title	Page
1	Measuring for Combination Cradle with Center Impact Roll.	3
2	Measuring for Combination Cradle with Center Impact Bars	4
3	EVO [®] Combination Cradle, P/N UCGBB-XXXXXMUPAX	13
4	EVO [®] Combination Cradle with Center Rolls, P/N UCGBR-XXXXXMUPAX.	16
5	Conveyor Products Warning Label, P/N 23395	19

List of Tables

Table	Title	Page
I	EVO [®] Combination Cradle Materials and Specifications	1
II	EVO [®] Combination Cradle Part Numbers and Quantities	15
III	EVO [®] Combination Cradle with Center Rolls Part Numbers and Quantities	18

Introduction

General

The EVO[®] Combination Cradles are layered, shock-absorbing conveyor belt transfer point products engineered for use in bulk solids handling industries.

References

The following documents are referenced in this manual:

- American National Standards Institute (ANSI) z244.1-1982, *American National Standard for Personnel Protection - Lockout/Tagout of Energy Sources - Minimum Safety Requirements*, American National Standards Institute, Inc., 1430 Broadway, New York, NY 10018.
- Federal Register, Volume 54, Number 169, Part IV, 29 CFR Part 1910, *Control of Hazardous Energy Source (Lockout/Tagout); Final Rule*, Department of Labor, Occupational Safety and Health Administration (OSHA), 32nd Floor, Room 3244, 230 South Dearborn Street, Chicago, IL 60604.

Combination Cradle Materials

Materials and specifications for the EVO[®] Combination Cradles are shown in Table I.

Table I. Combination Cradle Materials and Specifications

Characteristics		Urethane Bar
MSHA-Accepted for Underground Use		NA
Coefficient of Friction		0.5
Service Temperature		-20 to 160°F (-29 to 70°C)
Bar Construction	Bearing Layer	UHMW Polyethylene
	Absorption Layer	Urethane 83A
	T-Slot	Aluminum
	Fasteners	0.5-in. dia. Cap Screws

Safety

All safety rules defined in the above documents and all owner/employer safety rules must be strictly followed when working on this equipment.

Materials Required

Only standard hand tools are required to install and service this equipment.

Before Installing Combination Cradle

1. Inspect shipping container for damage. Report damage to delivery service immediately and fill out delivery service's claim form. Keep any damaged goods subject to examination.
2. Remove combination cradle from shipping container. Equipment in container should include the following:
 - EVO® Combination Cradle Assembly
 - Two Conveyor Products Warning Labels, P/N 23395
3. If anything is missing or damaged, contact Martin Engineering or a representative.
4. Make sure belt is centered on conveyor.



⚠ WARNING

Before installing equipment, turn off and lock out/tag out energy source to conveyor and conveyor accessories.

5. Turn off and lock out/tag out energy source according to ANSI standards (see "References").

⚠ WARNING

If equipment will be installed in an enclosed area, gas level or dust content must be tested before using a cutting torch or welding. Using a cutting torch or welding in an area with gas or dust may cause an explosion.

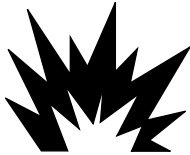

6. If using a cutting torch or welding, test atmosphere for gas level or dust content. Cover conveyor belt with fire retardant cover.
7. If not already present, install an impact idler 1 in. (25 mm) ahead of and 1 in. (25 mm) behind combination cradle location.
8. Remove any unnecessary idlers.

Installing Combination Cradle

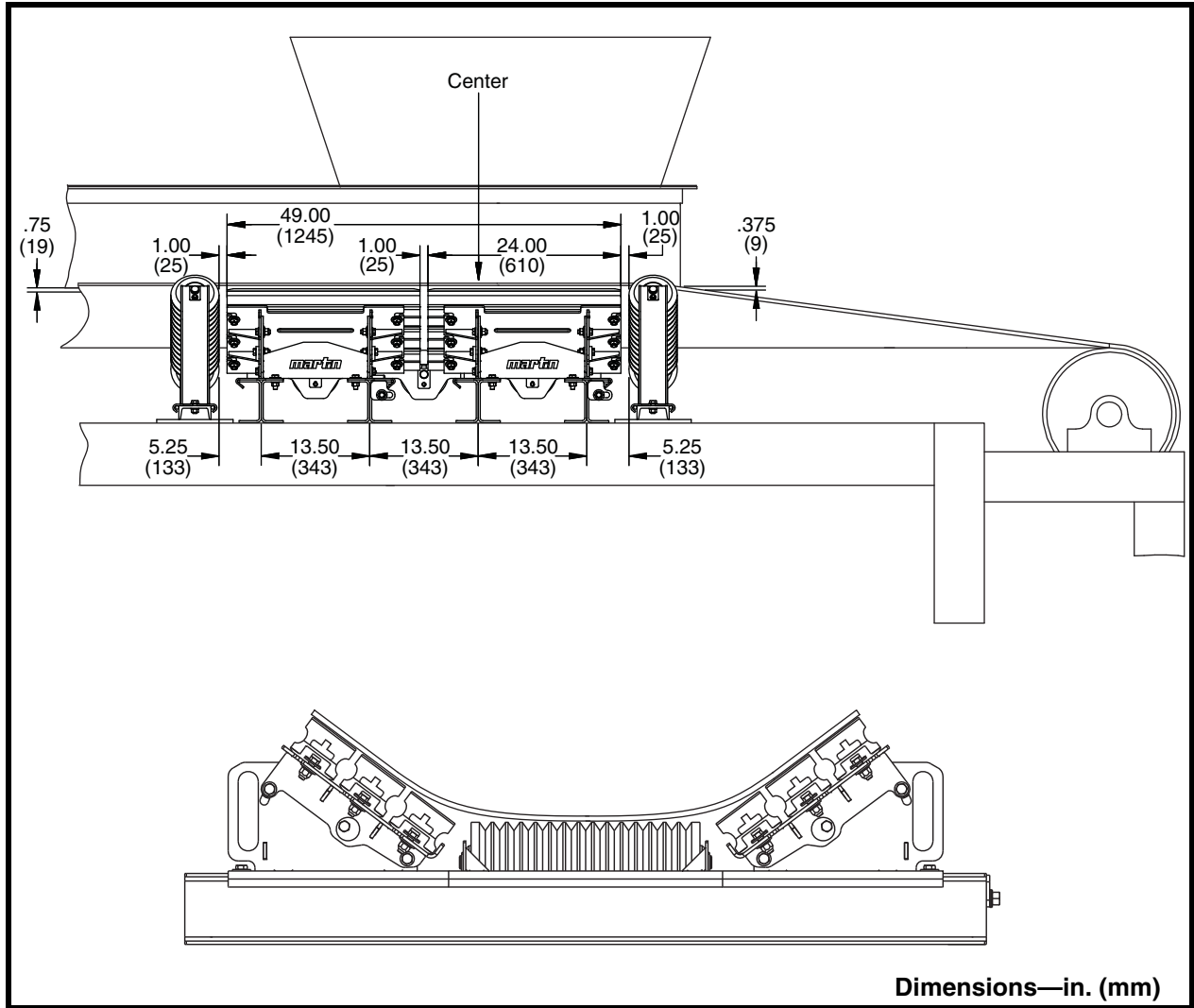

Figure 1. Measuring for Combination Cradle with Center Impact Roll

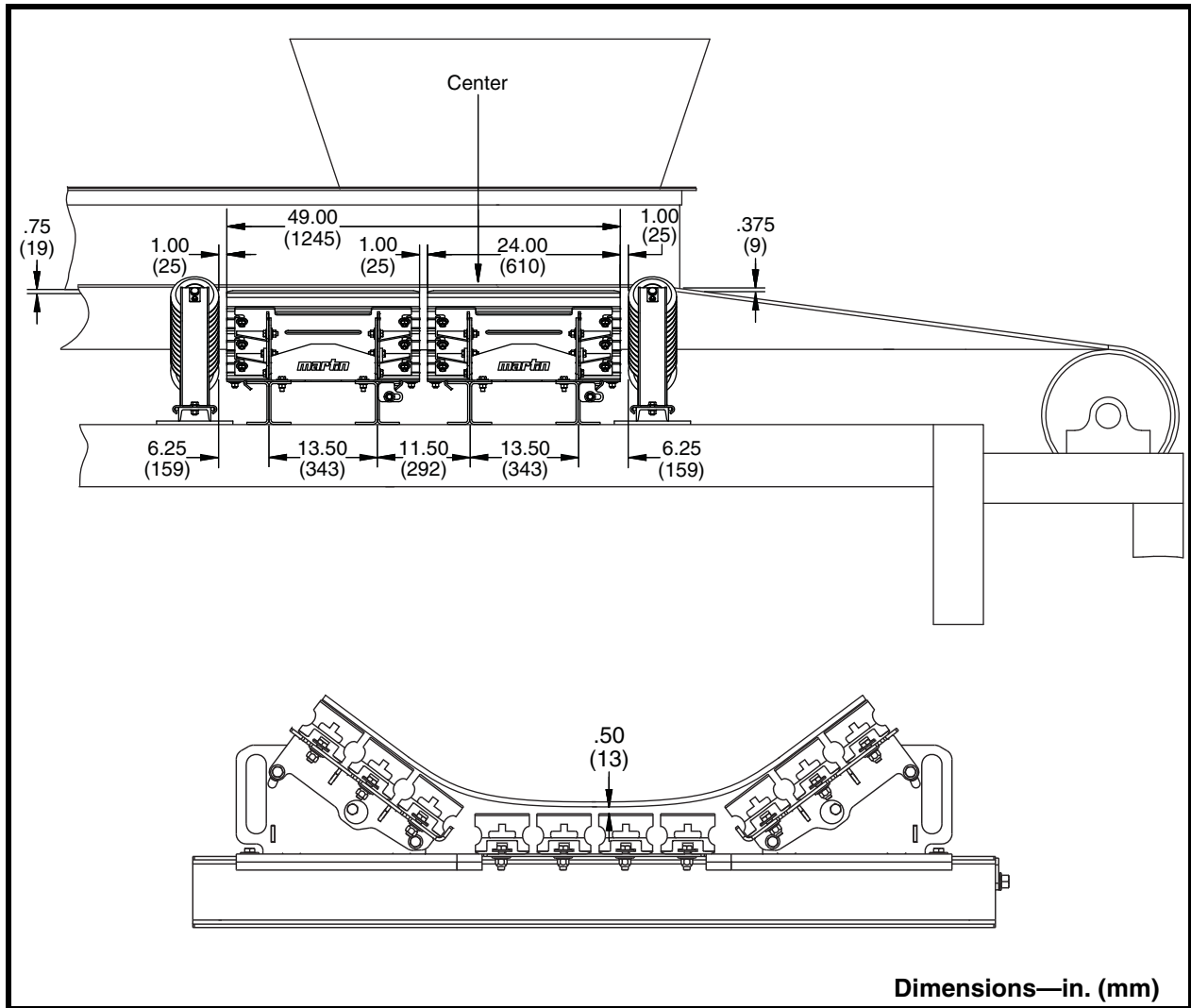

Figure 2. Measuring for Combination Cradle with Center Impact Bars

1. See Figure 1 or 2. The distance between top of belt and bottom of wear liners must increase over length of transfer point. If necessary, modify chute walls and/or wear liners.
2. Mark center of loading point on stringer; both sides of belt.

NOTE

A maximum of two combination cradles can be installed between idlers.

3. Install an idler 1 in. (25 mm) before and 1 in. (25 mm) after combination cradle(s).
4. When using impact roll in center of cradle make sure belt will contact roll.
5. When using impact bars in center of cradle make sure clearance between belt and bars will be 1/2 in. (13 mm).
6. Make sure clearance between belt and wing section is 1/2 in. (13 mm) where wing section meets center section and tapers to no clearance between belt and wing section at outside edge.

**Installation on
EVO[®] Stringer**

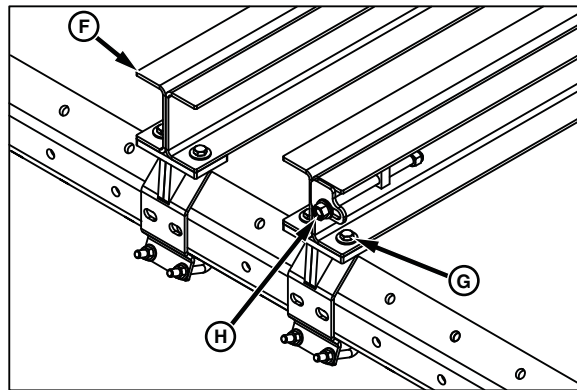
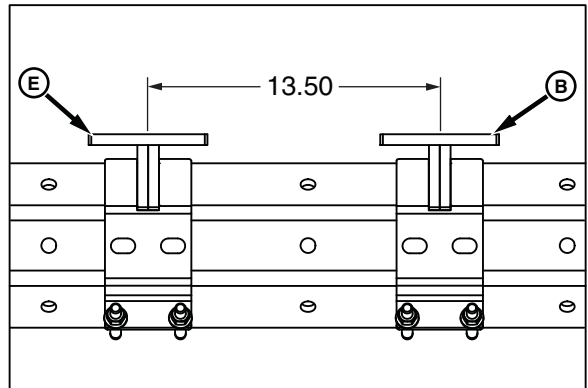
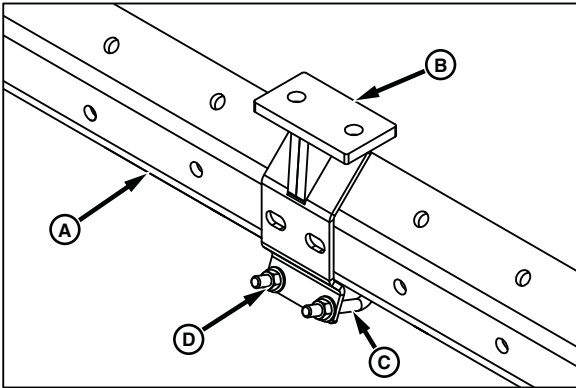

- A. Stringer**
- B. Bracket (2 used)**
- C. J-bolt (8 used)**
- D. Lock Washer and Nut (8 used)**

- E. Bracket (2 used)**
- F. Cross Support (2 used)**
- G. Cap Screw, Washers, and Nut (8 used)**
- H. Lock Mechanism**

1. Mark location of cross supports (B) on stringers (A). See Figure 1 or 2 for mounting dimensions.
2. Install bracket (B) on stringer using J-bolts (C), lock washers, and nuts (D).
3. Measure 13-1/2 in. from center of bracket (B) to center of bracket (F).
4. Install bracket (E) on stringer using J-bolts, lock washers, and nuts.
5. Repeat steps 1–4 for brackets on opposite side of conveyor.
6. Install cross supports (F) onto brackets using cap screws, washers, and nuts (G).
7. Make sure lock mechanism (H) is on the outside of the cross support.
8. Make sure cross supports are perpendicular to belt, or bars will wear unevenly and maintenance will be difficult.

Installation on Standard Stringer

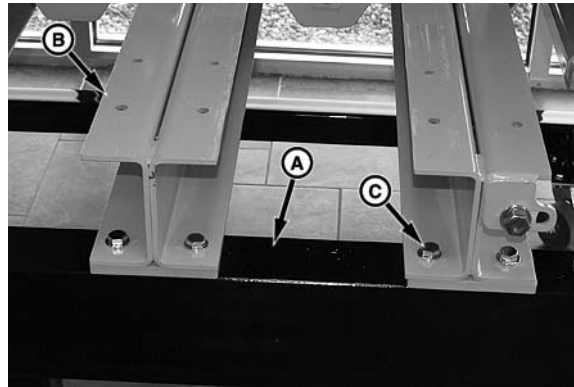

- A. Stringer**
- B. Cross Support (2 used)**
- C. Cap Screw, Washers, and Nut (8 used)**

1. Mark location of cross supports (B) on stringers (A). See Figure 1 or 2 for mounting dimensions.
2. Position cross supports on stringers.
3. Make sure cross supports are perpendicular to belt and centered below belt, or bars will wear unevenly and maintenance will be difficult.
4. When using impact roll in center of cradle make sure belt will contact roll.
5. When using impact bars in center of cradle make sure clearance between belt and bars will be 1/2 in. (13 mm):
 - a. For conveyors using CEMA D6 idlers install 1/2 in. shim plates included in cradle assembly hardware kit.
 - b. For conveyors using CEMA E6 or E7 idlers order and install shim kit P/N UC-001710 from Martin Engineering.
 - c. If clearance is greater than 1/2 in. after installing appropriate shims, order and install shim kit P/N UC-001710 from Martin Engineering.
 - d. If clearance is less than 1/2 in. contact Martin Engineering or a representative.

NOTE

Martin Engineering recommends bolting rather than welding cross supports to stringers for easier accessibility and maintenance.

6. Bolt or weld cross supports to stringers as follows:
 - a. If bolting, drill or cut 9/16-in. holes in stringers through mounting holes in feet of cross supports. Install cap screw, flat washer, compression washer, and nut (C) in each hole to secure cross supports to stringers.
 - b. If welding, clean stringer of rust and dirt. Then stitch weld cross supports to stringers.

Installing Impact Bars

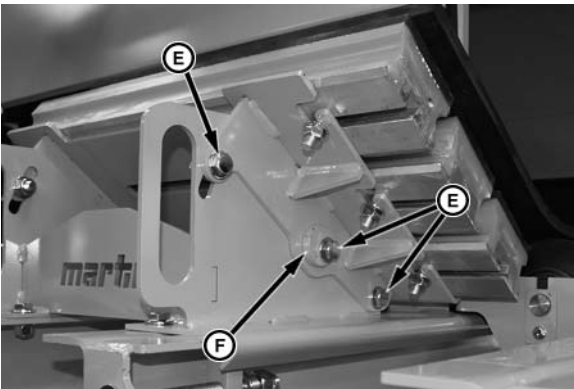
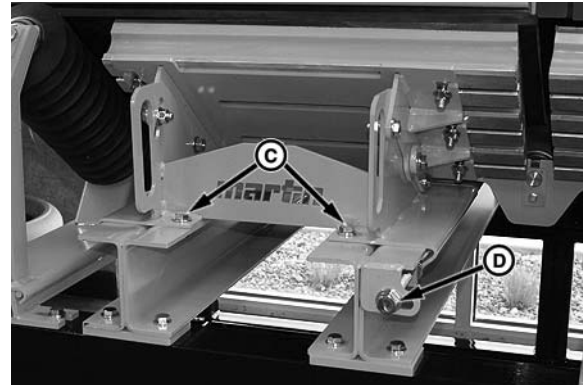

- A. Wing Weldment (2 used)**
- B. Center Weldment**
- C. Cap Screw, Washer, and Nut (4 used)**
- D. Cap Screw**
- E. Cap Screw, Washer, and Nut**
- F. Eccentric**

1. Slide center weldment (B) with bars/rolls onto cross supports. Position the weldment under the center of the belt.
2. Slide wing weldment (A) with bars onto cross supports until weldment contacts center weldment. Install second wing weldment on opposite side.
3. Center cradle under belt.
4. Insert cap screws, washers, and nuts (C) through wing weldments into cross supports.
5. Tighten cap screw (D) on lock mechanism to lock the weldments in place.
6. Loosen cap screws, washers, and nuts (E).
7. Rotate eccentric (F) to position impact bars against belt.
8. Tighten cap screws, washers, and nuts (E).
9. When using impact roll in center of cradle make sure belt is contacting roll.
10. When using impact bars in center of cradle make sure clearance between belt and bars is 1/2 in. (13 mm).
11. Make sure clearance between belt and wing section is 1/2 in. (13 mm) where wing section meets center section and tapers to no clearance between belt and wing section at outside edge.
12. Make sure there is 1 in. of clearance between bars and idler on both ends of cradle.

After Installing Combination Cradle

IMPORTANT

Read entire section before beginning work.

1. Thoroughly wipe outside chute walls clean above combination cradle on both sides of chute. Place a Conveyor Products Warning Label (P/N 23395) on each chute wall visible to belt operator.

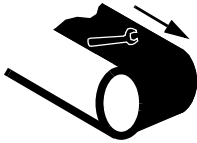

WARNING

Failure to remove tools from installation area and conveyor belt before turning on energy source can cause serious injury to personnel and damage to belt.

2. Remove all tools and fire retardant cover from installation area and conveyor belt.



DANGER

Do not touch or go near conveyor belt or conveyor accessories when conveyor belt is running. Body or clothing can get caught and pull body into conveyor belt, causing severe injury or death.

3. Turn on conveyor belt.



WARNING

Before adjusting combination cradle, turn off and lock out/tag out energy source to conveyor belt and conveyor accessories.

4. After 1 hour of operation, turn off and lock out/tag out energy source according to ANSI standards (see “References”).
5. Make sure all fasteners are tight. Tighten if necessary.
6. Inspect impact bars for wear. (A small amount of “break-in” wear may be found. This will stop once the bars wear to conveyor belt contour.)
7. If excessive wear, uneven wear, or some other problem exists, see “Troubleshooting/ Installation Checklist.”

IMPORTANT

Read entire section before beginning work.



WARNING

Before servicing combination cradle, turn off and lock out/tag out energy source to conveyor belt and conveyor accessories.

1. Turn off and lock out/tag out energy source according to ANSI standards (see “References”).
2. Make sure all fasteners are tight. Tighten if necessary.



A. Impact Bar

B. Cap Screw, Washer, and Nut

3. Check bars for wear. If top cover on bars is worn through to orange urethane, replace bars as follows:
 - a. Loosen cap screw on lock mechanism.
 - b. Remove cap screws, washers, and nuts holding wing weldment to cross support.
 - c. Remove wing weldments and center weldment.
 - d. Replace impact bars (A) on each weldment as follows:
 - (1) Loosen cap screws, washers, and nuts (B).
 - (2) Slide bar so cap screws will fit through slots and bar can be removed.
 - (3) Replace worn bars and reinstall in reverse order.
4. Remove fines between impact bars with broom or high-pressure air or water.
5. Inspect combination cradle for cracks or fatigue. Weld or strengthen structure as necessary.
6. Wipe warning labels clean. If labels are not readable, contact Martin Engineering or a representative for replacements.

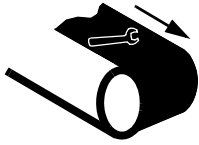

⚠ WARNING

Failure to remove tools from maintenance area and conveyor belt before turning on energy source can cause serious injury to personnel and damage to belt.

7. Remove all tools from maintenance area.

⚠ DANGER

Do not touch or go near conveyor belt or conveyor accessories when conveyor belt is running. Body or clothing can get caught and pull body into conveyor belt, causing severe injury or death.

8. Start conveyor belt.



Troubleshooting/Installation Checklist

Troubleshooting

If you are experiencing problems with EVO® Combination Cradle, see below:

Symptom	Corrective Action
High impact bar wear rate.	Combination cradle is installed too close to belt. Make sure combination cradle center impact bars are 1/2 in. (13 mm) below belt.
Impact bars worn unevenly.	Belt is unevenly loaded, wear liners are improperly installed, and/or impact bars are not parallel to belt travel. Inspect loading area and wear liners, and modify transfer point if necessary.

Installation checklist

If after taking corrective actions suggested under “Troubleshooting” you are still experiencing problems, check for the following:

Installation Checklist
Chute walls and/or wear liners are 3/8 in. above belt at tail and 3/4 in. above belt at head.
Combination cradle aligns with center of loading point.
An idler is installed 1 in. (25 mm) before and 1 in. (25 mm) after combination cradle.
Center impact bars/rolls are centered below belt and are parallel to belt travel.
Wing sections are aligned with idlers.
When using impact roll in center of cradle make sure belt is contacting roll.
When using impact bars in center of cradle make sure clearance between top of center impact bars and bottom of belt surface is 1/2 in. (13 mm).

Part Numbers

This section provides product names and corresponding part numbers for EVO[®] Combination Cradles. Please reference part numbers when ordering parts.

***EVO[®]
Combination
Cradle***

EVO[®] Combination Cradle, P/N UCGBB-XXXXXMUPAX

**EVO[®] Combination Cradle with Center Rolls,
P/N UCGBR-XXXXXMUPAX**

Miscellaneous

Shim Kit: P/N UC-001710.

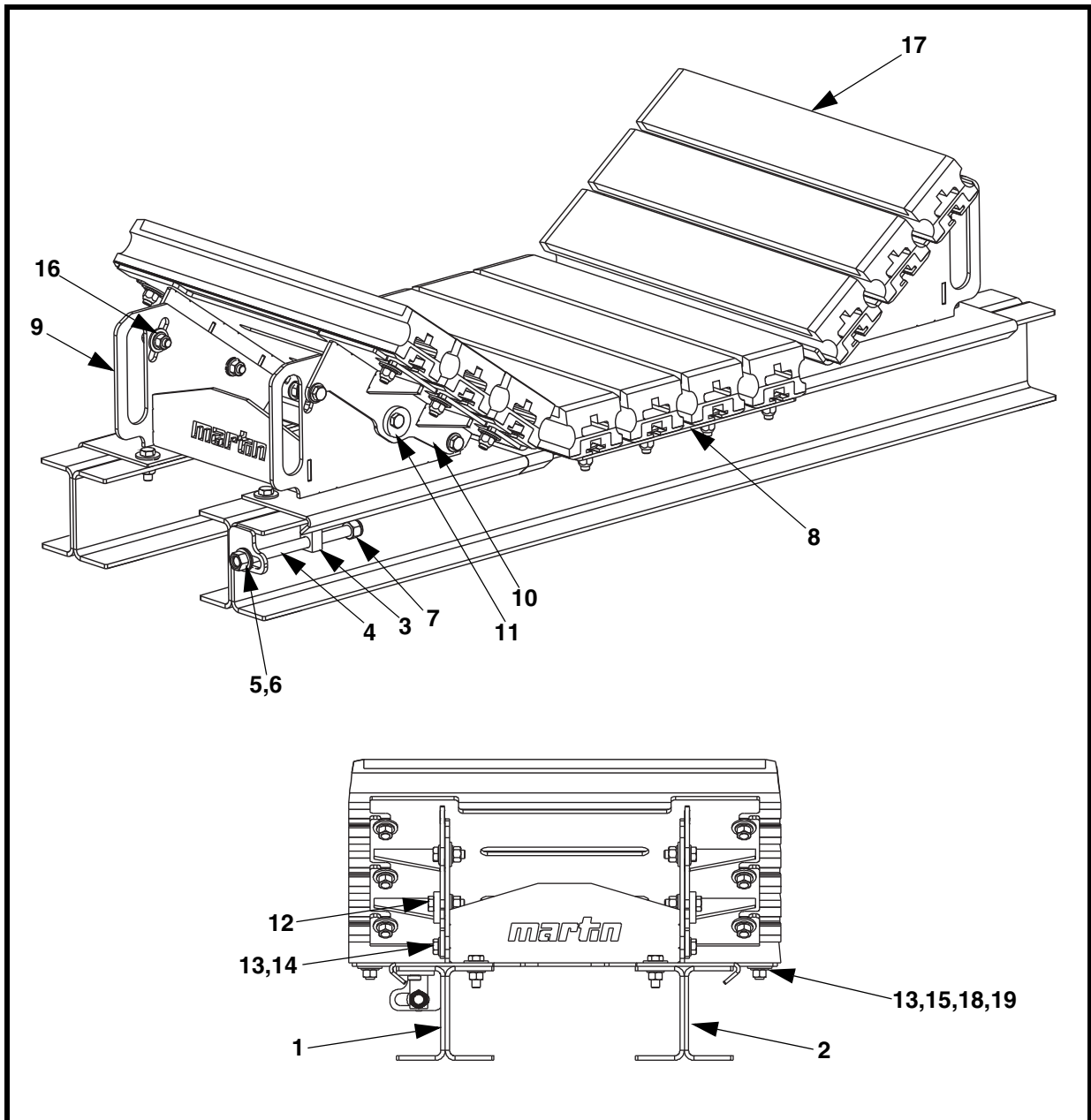

Figure 3. EVO[®] Combination Cradle, P/N UCGBB-XXXXXMUPAX

Item	Description	Part No.	Qty
1	Cross Support Weldment (Locking)	UC-001600L-XXX*	1
2	Cross Support Weldment	UC-001600-XXX*	1
3	Locking Weldment	UC-001640-XX**	1
4	Draw Bolt 5/8-11NC SS	Table II	1
5	Washer Flat 5/8 Narrow ZP	16814	1
6	Washer Compression 5/8	11752	1
7	Nut Hex Elastic Lock 5/8-11NC ZP	22624	1
8	Center Sleeve	UC-001611-XX**	1
9	Wing Weldment	UC-001620-XXXX***	2
10	Wing Plate Weldment	UC-001650-XXXX***	2
11	Eccentric	Table II	4
12	Screw HHC 1/2-13NC x 1-3/4 ZP	36228	4
13	Screw HHC 1/2-13NC x 1-1/2 ZP	11763	Table II
14	Washer Flat 1/2 Narrow ZP	31010	Table II
15	Washer Compression 1/2	11750	Table II
16	Nut Hex 1/2-13NC ZP	11771	8
17	Impact Bar	39102-2	Table II
18	Washer Flat 1/2 Wide ZP	17328	Table II
19	Nut Hex Lock 1/2-13NC All Metal	36215	Table II
20 (NS)	Mounting Kit	Table II	1
21 (NS)	Label Kit	34042	1
22 (NS)	Operator's Manual	M3896	1

NS = Not Shown

Figure 3. EVO[®] Combination Cradle, P/N UCGBB-XXXXXMUPAX

First XX indicates belt width. Third X indicates Standard (S) or Wide (W) base stringer. Next XX indicates trough angle 20, 35, or 45 degrees. The M indicates Medium CEMA Duty Rating. The U indicates Urethane Impact Bar. The P indicates Painted Steel. The A indicates Shipping Assembled. Last X indicates EVO[®] (E) or Standard (S) stringer.

*First XX indicates belt width. Third X indicates Standard (S) or Wide (W) base stringer.

**XX indicates belt width.

***First XX indicates belt width. Next XX indicates trough angle.

Table II. EVO® Combination Cradle Part Numbers and Quantities

Part No.	P/N Item 11	Qty Item 13	Qty Item 14	Qty Items 15	Qty Item 17	Qty Item 18	Qty Item 19
UCGBB-24SXXMUPAX	35994	12	4	16	6	24	12
UCGBB-30SXXMUPAX	35994	14	4	18	7	28	14
UCGBB-36SXXMUPAX	35994	14	4	18	7	28	14
UCGBB-42SXXMUPAX	35994	22	8	26	9	40	18
UCGBB-48SXXMUPAX	35994	24	8	28	10	44	20
UCGBB-54SXXMUPAX	35994-L	28	8	32	12	52	24
UCGBB-60SXXMUPAX	35994-L	30	8	34	13	56	26
UCGBB-72SXXMUPAX	35994-L	36	8	40	16	68	32

Part Numbers

Part No.	P/N Item 4
UCGBB-XXSXXMUPAX	UC-001504
UCGBB-XXWXXMUPAX	UC-001504W

Part No.	P/N Item 20
UCGBB-XXXXXMUPAE	UC-001680
UCGBB-XXXXXMUPAS	UC-001690

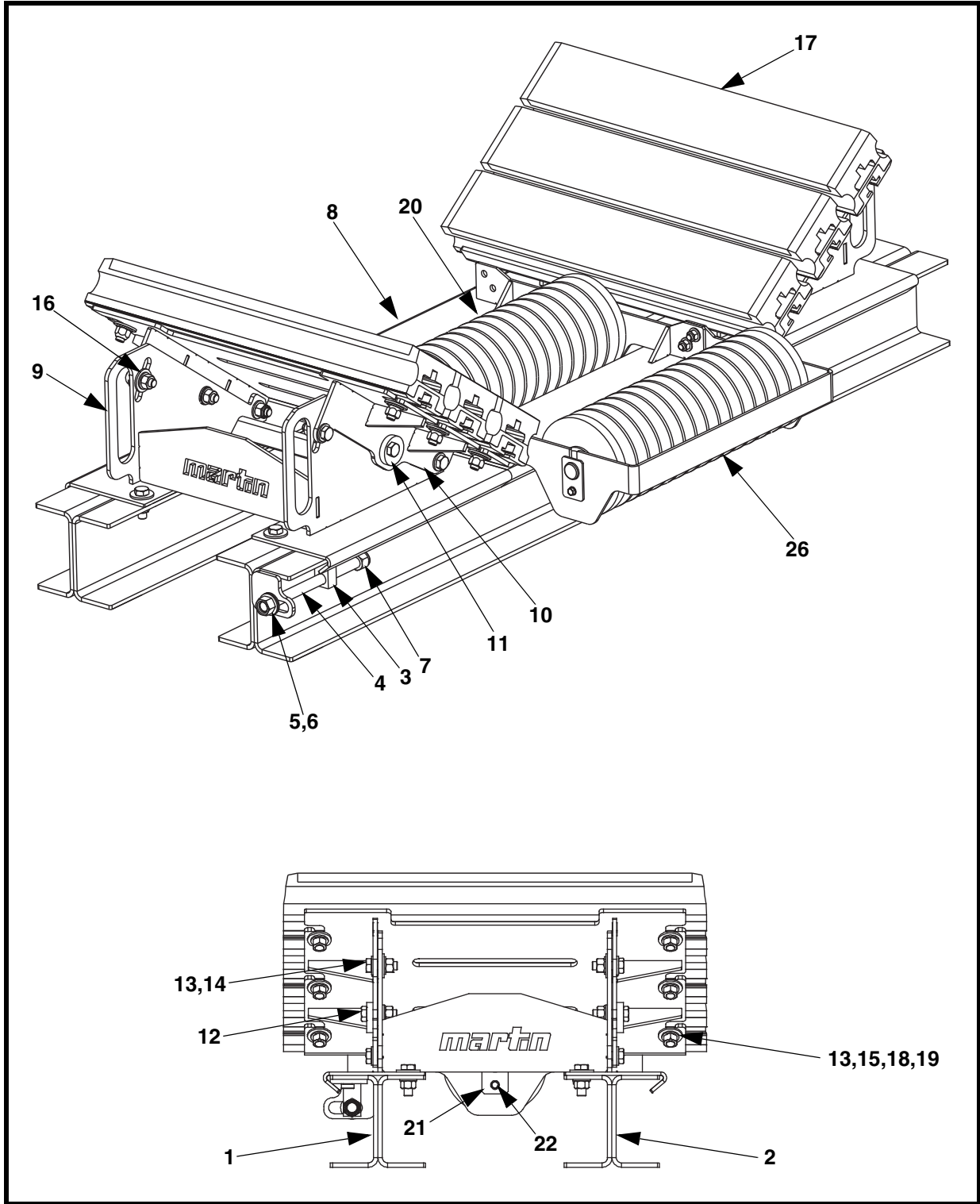

Figure 4. EVO® Combination Cradle with Center Rolls, P/N UCGBR-XXXXXMUPAX

Item	Description	Part No.	Qty
1	Cross Support Weldment (Locking)	UC-001600L-XXX*	1
2	Cross Support Weldment	UC-001600-XXX*	1
3	Locking Weldment	UC-001640-XX**	1
4	Draw Bolt 5/8-11NC SS	Table III	1
5	Washer Flat 5/8 Narrow ZP	16814	1
6	Washer Compression 5/8	11752	1
7	Nut Hex Elastic Lock 5/8-11NC ZP	22624	1
8	Center Roll Weldment	UC-001611-XX**	1
9	Wing Weldment	UC-001620-XXXX***	2
10	Wing Plate Weldment	UC-001650-XXXX***	2
11	Eccentric	Table III	4
12	Screw HHC 1/2-13NC x 1-3/4 ZP	36228	4
13	Screw HHC 1/2-13NC x 1-1/2 ZP	11763	Table III
14	Washer Flat 1/2 Narrow ZP	31010	Table III
15	Washer Compression 1/2	11750	Table III
16	Nut Hex 1/2-13NC ZP	11771	8
17	Impact Bar	39102-2	Table III
18	Washer Flat 1/2 Wide ZP	17328	Table III
19	Nut Hex Top Lock 1/2-13NC GR 8 PP	36215	Table III
20	Roll Impact	TMIRD-XXIP**	1
21	Tie Tab	UC-002001	2
22	Screw Tapping HWH 1/4-20NC x 3/8 ZP	38608	2
23 (NS)	Mounting Kit	Table III	1
24 (NS)	Label Kit	34042	1
25 (NS)	Operator's Manual	M3896	1
26	Roller Cradle Roller Kit	UC-001670-XX**	1

NS = Not Shown

Figure 4. EVO[®] Combination Cradle with Center Rolls, P/N UCGBR-XXXXXMUPAX

First XX indicates belt width. Third X indicates Standard (S) or Wide (W) base stringer. Next XX indicates trough angle 20, 35, or 45 degrees. The M indicates Medium CEMA Duty Rating. The U indicates Urethane Impact Bar. The P indicates Painted Steel. The A indicates Shipping Assembled. Last X indicates EVO[®] (E) or Standard (S) stringer.

*First XX indicates belt width. Third X indicates Standard (S) or Wide (W) base stringer.

**XX indicates belt width.

***First XX indicates belt width. Next XX indicates trough angle.

Table III. EVO® Combination Cradle with Center Rolls Part Numbers and Quantities

Part No.	P/N Item 11	Qty Item 13	Qty Item 14	Qty Item15	Qty Item 17	Qty Item 18	Qty Item 19
UCGBR-24XXXMUPAX	35994	8	4	12	4	16	8
UCGBR-30XXXMUPAX	35994	8	4	12	4	16	8
UCGBR-36XXXMUPAX	35994	8	4	12	4	16	8
UCGBR-42XXXMUPAX	35994	16	8	20	6	28	12
UCGBR-48XXXMUPAX	35994	16	8	20	6	28	12
UCGBR-54XXXMUPAX	35994-L	20	8	24	8	36	16
UCGBR-60XXXMUPAX	35994-L	20	8	24	8	36	16
UCGBR-72XXXMUPAX	35994-L	24	8	28	10	44	20

Part No.	P/N Item 4
UCGBR-XXSXXMUPAX	UC-001504
UCGBR-XXWXXMUPAX	UC-001504W

Part No.	P/N Item 23
UCGBR-XXXXXMUPAE	UC-001680
UCGBR-XXXXXMUPAS	UC-001690

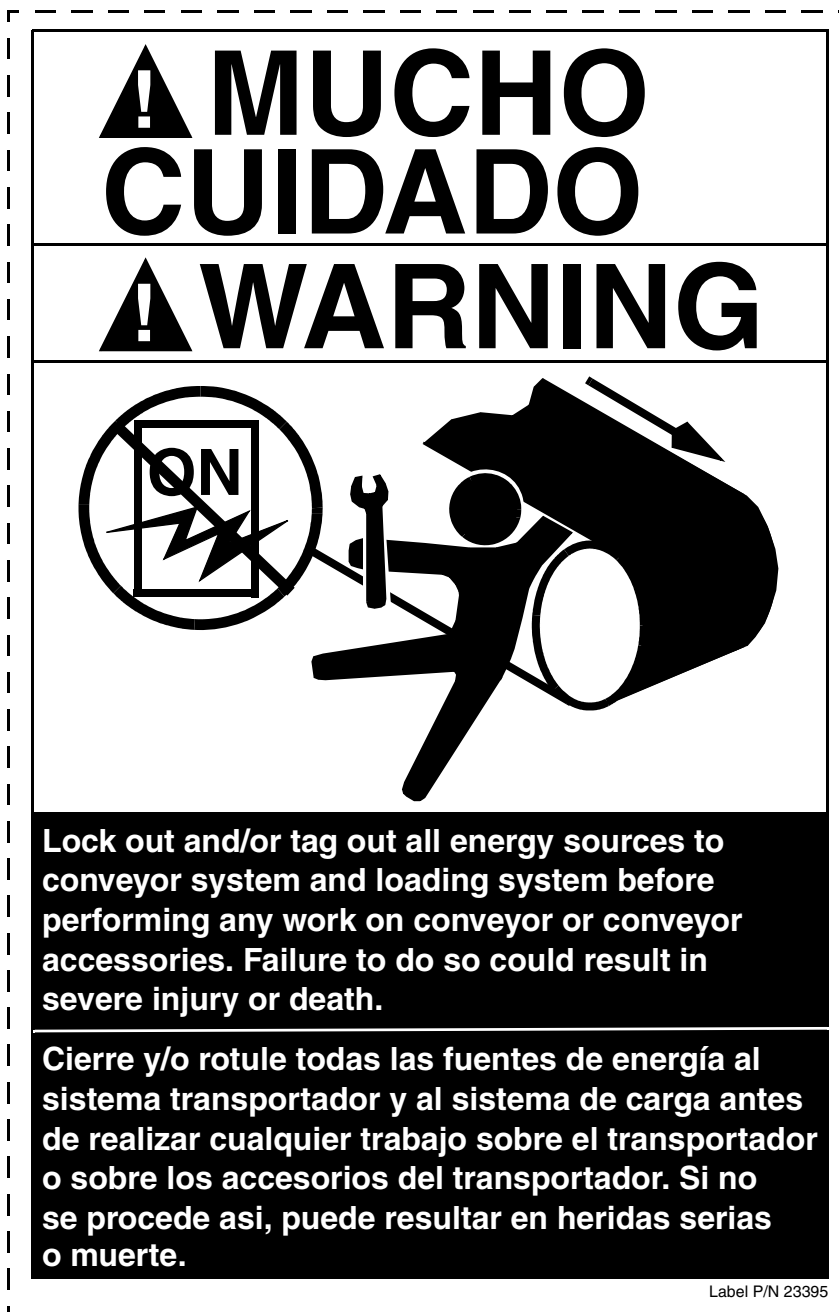
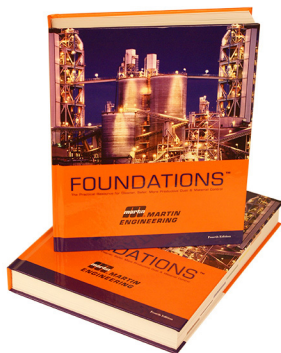

Figure 5. Conveyor Products Warning Label, P/N 23395

Any product, process, or technology described here may be the subject of intellectual property rights reserved by Martin Engineering Company. Trademarks or service marks designated with the ® symbol are registered with the U.S. Patent and Trademark Office and may be proprietary in one or more countries or regions. Other trademarks and service marks belonging to Martin Engineering Company in the United States and/or other countries or regions may be designated with the “TM” and “SM” symbols. Brands, trademarks, and names of other parties, who may or may not be affiliated with, connected to, or endorsed by Martin Engineering Company, are identified wherever possible. Additional information regarding Martin Engineering Company’s intellectual property can be obtained at www.martin-eng.com/trademarks.

Problem Solved™ GUARANTEED!



For nearly 20 years, Martin Engineering's Foundations™ Books have taught industry personnel to operate and maintain clean and safe belt conveyors. The Foundations™ Book, fourth edition, focuses on improving belt conveyors by controlling fugitive material. "The Practical Resource for Total Dust and Material Control," is a 576-page hard cover volume that provides information of value to industries where the efficient handling of bulk materials is a key to productivity and profitability.

Expanding upon the book, our Foundations™ Training Program addresses the design and development of more productive belt conveyors, and is offered in three customizable seminars. Attendees gain a better understanding of conveyor safety and performance, helping to justify upgrade investments and increase profitability.



Martin Engineering USA

One Martin Place
Neponset, IL 61345-9766 USA
800 544 2947 or 309 852 2384
Fax 800 814 1553
www.martin-eng.com

**COMPANY WITH
QUALITY SYSTEM
CERTIFIED BY DNV
= ISO 9001:2008 =**