

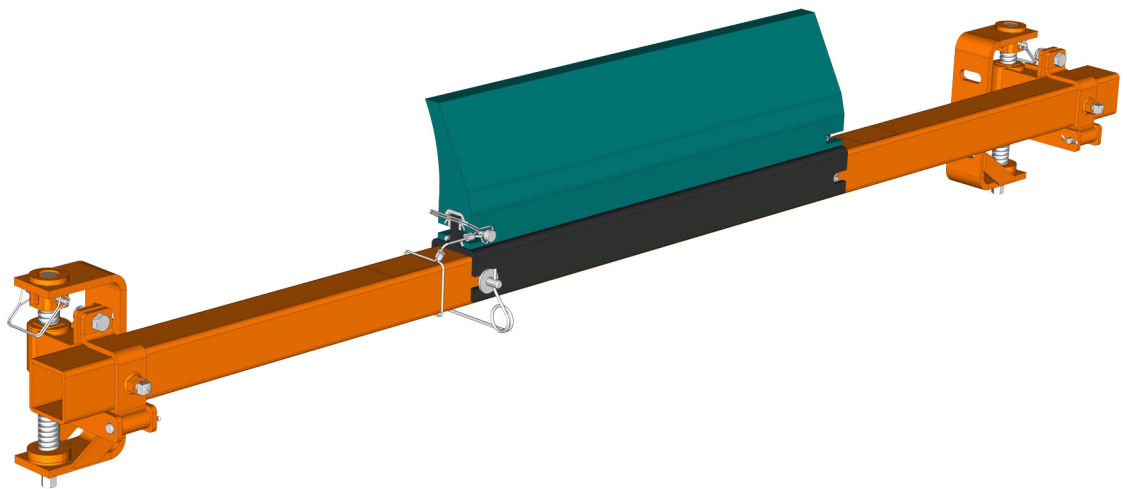

# **Martin<sup>®</sup> H2O Cleaner**

[Go to Martin<sup>®</sup> H2O Cleaner web page](#)



***Operator's Manual***  
***M3825***

# Important

MARTIN ENGINEERING HEREBY DISCLAIMS ANY LIABILITY FOR: DAMAGE DUE TO CONTAMINATION OF THE MATERIAL; USER'S FAILURE TO INSPECT, MAINTAIN AND TAKE REASONABLE CARE OF THE EQUIPMENT; INJURIES OR DAMAGE RESULTING FROM USE OR APPLICATION OF THIS PRODUCT CONTRARY TO INSTRUCTIONS AND SPECIFICATIONS CONTAINED HEREIN. MARTIN ENGINEERING'S LIABILITY SHALL BE LIMITED TO REPAIR OR REPLACEMENT OF EQUIPMENT SHOWN TO BE DEFECTIVE.

Observe all safety rules given herein along with owner and Government standards and regulations. Know and understand lockout/tagout procedures as defined by American National Standards Institute (ANSI) z244.1-1982, *American National Standard for Personnel Protection - Lockout/Tagout of Energy Sources - Minimum Safety Requirements* and Occupational Safety and Health Administration (OSHA) Federal Register, Part IV, 29 CFR Part 1910, *Control of Hazardous Energy Source (Lockout/Tagout); Final Rule*.

The following symbols may be used in this manual:



**Danger:** Immediate hazards that will result in severe personal injury or death.



**Warning:** Hazards or unsafe practices that could result in personal injury.



**Caution:** Hazards or unsafe practices that could result in product or property damages.



**Important:** Instructions that must be followed to ensure proper installation/operation of equipment.



**Note:** General statements to assist the reader.

# Table of Contents

---

| <b>Section</b>                             | <b>Page</b> |
|--|-------------|
| List of Figures and Tables . . . . .       | ii          |
| Introduction . . . . .                     | 1           |
| General . . . . .                          | 1           |
| Installations without chutework . . . . .  | 1           |
| Belt cleaner inspection access . . . . .   | 1           |
| References . . . . .                       | 1           |
| Safety . . . . .                           | 2           |
| Urethane shelf life . . . . .              | 3           |
| Before Installing Belt Cleaner . . . . .   | 4           |
| Installing Belt Cleaner Assembly . . . . . | 5           |
| Marking chute cutouts . . . . .            | 5           |
| Removing blade . . . . .                   | 6           |
| Installing tensioner . . . . .             | 6           |
| Installing blade . . . . .                 | 6           |
| After Installing Belt Cleaner . . . . .    | 7           |
| Weekly Maintenance . . . . .               | 8           |
| Troubleshooting . . . . .                  | 9           |
| Part Numbers . . . . .                     | 10          |

## **List of Figures**

---

| <b>Figure</b> | <b>Title</b>  | <b>Page</b> |
|---------------|---|-------------|
| 1             | Mounting Locations .....  | 5           |
| 2             | Removing and Installing Blade .....                               | 6           |
| 3             | Martin <sup>®</sup> H2O Cleaner Assembly, P/N H2O4000S-XXXX ..... | 11          |
| 4             | Conveyor Products Warning Label, P/N 23395 .....                  | 12          |

## **List of Tables**

---

| <b>Table</b> | <b>Title</b>  | <b>Page</b> |
|--------------|---|-------------|
| I            | Urethane Shelf Life .....                                   | 3           |
| II           | Martin <sup>®</sup> H2O Cleaner Assembly Part Numbers. .... | 12          |

# Introduction

---

## ***General***

To introduce product back into the product flow, a Pre-Cleaner is installed on the face of the head pulley. On a dual cleaner system, the Secondary Cleaner is installed immediately following the Pre-Cleaner to remove stubborn material left on the conveyor belt. If a Pre-Cleaner cannot be used because of space limitations, the Secondary Cleaner is installed alone. If the material-handling process or product could be affected by contamination from the use of these belt cleaners, the user is responsible for taking the necessary steps to prevent contamination. Consult Martin Engineering or a representative for alternate belt cleaners or belt cleaner locations to use where contamination may be an issue.

## ***Installations without chutework***

These procedures were written for equipment that is being installed on enclosed pulley chutework. If the pulley is not enclosed, the equipment should be installed using the best available field resources and methods to ensure that the critical dimensions are followed for proper installation.

## ***Belt cleaner inspection access***

If the belt cleaner is installed on enclosed pulley chutework, a Martin<sup>®</sup> Inspection Door should be installed. Martin<sup>®</sup> Inspection Doors are available from Martin Engineering or a representative.

## ***References***

The following documents are referenced in this manual:

- American National Standards Institute (ANSI) z244.1-1982, *American National Standard for Personnel Protection - Lockout/Tagout of Energy Sources - Minimum Safety Requirements*, American National Standards Institute Inc., 1430 Broadway, New York, NY 10018.
- Federal Register, Volume 54, Number 169, Part IV, 29 CFR Part 1910, *Control of Hazardous Energy Source (Lockout/Tagout); Final Rule*, Department of Labor, Occupational Safety and Health Administration (OSHA), 32nd Floor, Room 3244, 230 South Dearborn Street, Chicago, IL 60604.
- Martin<sup>®</sup> *SQC2S™ Square Mainframe Tensioners Operator's Manual*, P/N M3815

Safety

All safety rules defined in the above documents and all owner/employer safety rules must be strictly followed when working on the belt cleaner.



**⚠ DANGER**

Do not touch or go near the conveyor belt or conveyor accessories when the belt is running. Your body or clothing can get caught and you can be pulled into the conveyor, resulting in severe injury or death.



**⚠ DANGER**

Before installing, servicing, or adjusting the belt cleaner, turn off and lock out/tag out all energy sources to the conveyor and conveyor accessories according to ANSI standards. Failure to do so could result in serious injury or death.

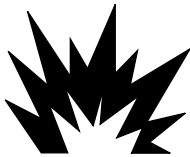

**⚠ DANGER**

If this equipment will be installed in an enclosed area, test the gas level or dust content before using a cutting torch or welding. Using a torch or welding in an area with gas or dust may cause an explosion resulting in serious injury or death.



**⚠ WARNING**

Before using a cutting torch or welding the chute wall, cover the conveyor belt with a fire retardant cover. Failure to do so can allow the belt to catch fire.

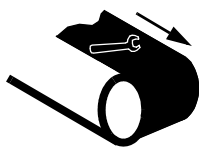

**⚠ WARNING**

Remove all tools from the installation area and conveyor belt before turning on the conveyor. Failure to do so can cause serious injury to personnel or damage to the belt and conveyor.



**⚠ WARNING**

Mainframe with blade can be heavy and may require two people to lift. Attempting to lift the belt cleaner without assistance could result in injury.

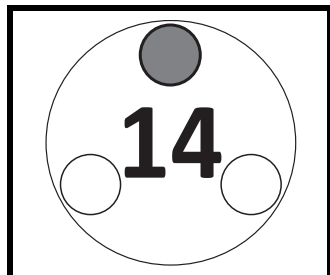
*Urethane shelf life***IMPORTANT**

Urethane put in service after exceeding its shelf life may wear differently and deteriorate quicker than normal urethane.

**NOTE**

Code Date is written near bottom of blade as mm/dd/yy-x. In addition to or in place of this date, you may see an imprinted date medallion similar to the example shown. In this example, "14" stands for the year 2014. The small circles represent the quarter of the year. If three circles are "punched" the blade was produced in the first quarter. If none of the circles are "punched" the blade was produced in the fourth quarter. If code date on your blade(s) is not legible or is missing, contact Martin Engineering or a representative.

Table I. Urethane Shelf Life

| Blade Color | Shelf Life             |
|-------------|------------------------|
| Blue        | 1 Year from Code Date  |
| Brown       | 2 Years from Code Date |
| Clear       | 1 Year from Code Date  |
| Green       | 2 Years from Code Date |
| Orange      | 1 Year from Code Date  |

## Before Installing Belt Cleaner

### IMPORTANT

The delivery service is responsible for damage occurring in transit. Martin Engineering CANNOT enter claims for damages. Contact your transportation agent for more information.

1. Inspect shipping container for damage. Report damage to delivery service immediately and fill out delivery service's claim form. Keep any damaged goods subject to examination.
2. Remove belt cleaner assembly from shipping container.
3. If anything is missing contact Martin Engineering or a representative.



### WARNING

Before installing equipment, turn off and lock out/ tag out all energy sources to the conveyor and conveyor accessories according to ANSI standards. Failure to do so could result in serious injury or death.

4. Turn off and lock out/tag out energy source according to ANSI standards (see "References").

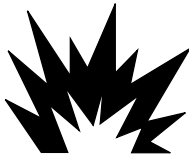

### DANGER

If this equipment will be installed in an enclosed area, test the gas level or dust content before using a cutting torch or welding. Using a torch or welding in an area with gas or dust may cause an explosion resulting in serious injury or death.

5. If using a cutting torch or welding, test atmosphere for gas level or dust content. Cover conveyor belt with fire retardant cover.

### IMPORTANT

Center the belt cleaner blades to clean an area narrower than the conveyor belt width. This allows for side-to-side movement of the belt and prevents damage to the belt edge.

### NOTE

The chute wall that the tensioner will be located on is referred to as the "operator side." The other side of the chute is referred to as the "far side." (If installing dual tensioners, side that is most accessible is "operator side.")

6. Determine which side of chute is easiest to access. Locate the tensioner on the most accessible chute wall.



# Installing Belt Cleaner Assembly

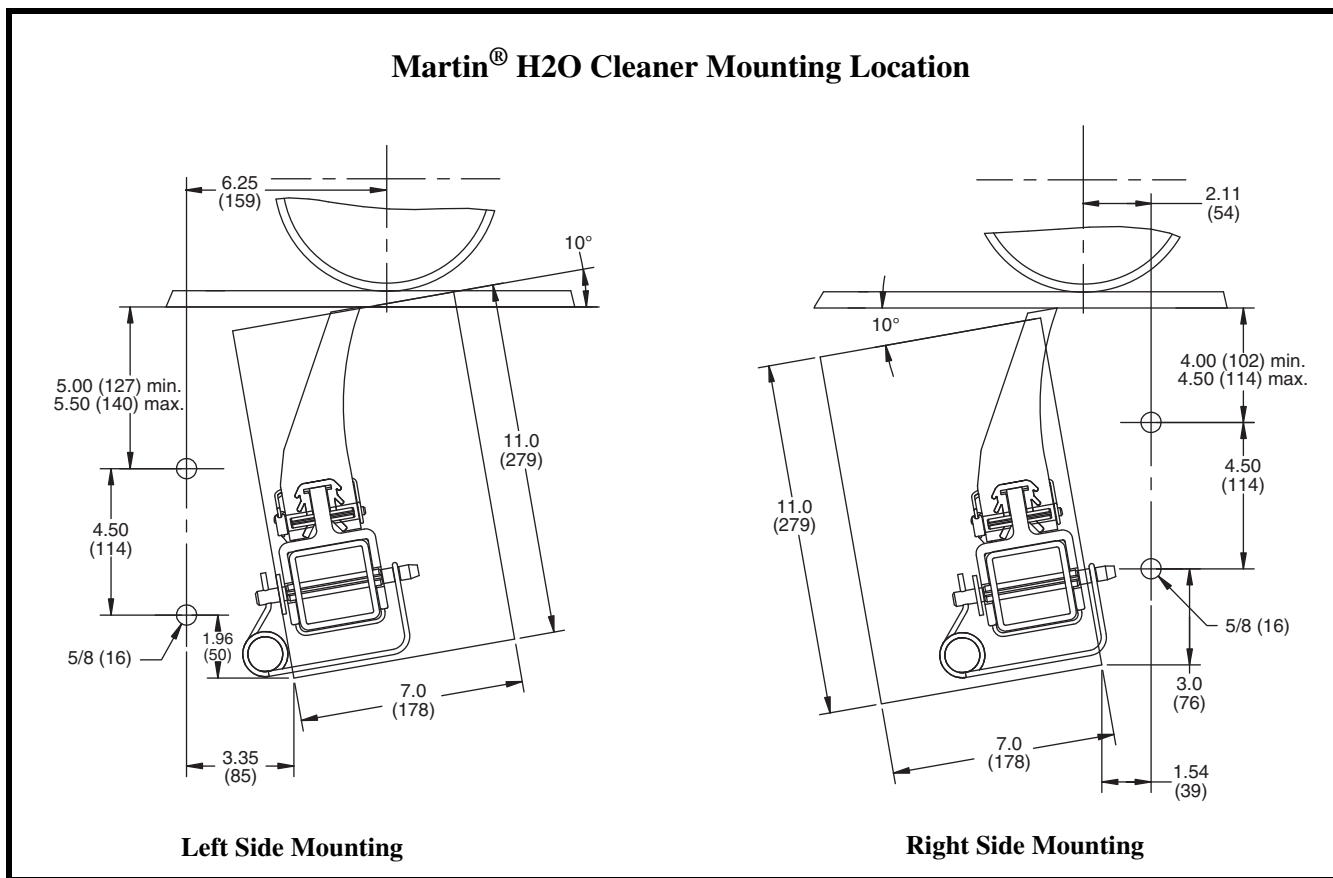

Figure 1. Mounting Locations

**NOTE**

Solid backing of the blade is essential to ensure proper operation and efficient cleaning. Install the cleaner adjacent to the head pulley or a flat pressure roller to obtain best cleaning results.

**NOTE**

For installation on enclosed head pulley chutework, draw all dimension lines on chute wall. In applications where head pulley is not enclosed, use the best available field resources and/or methods to ensure that these critical dimensions are followed for a proper installation.

**Marking chute cutouts**

1. Mark the chute cutout and mount hole locations as shown in Figure 1. Repeat on both sides of chute, ensuring cutouts are accurately aligned with each other.
2. At the selected mounting position, cut the cleaner access slots and drill the mount holes in each side of the chute. Dress and de-burr the holes and cutouts.

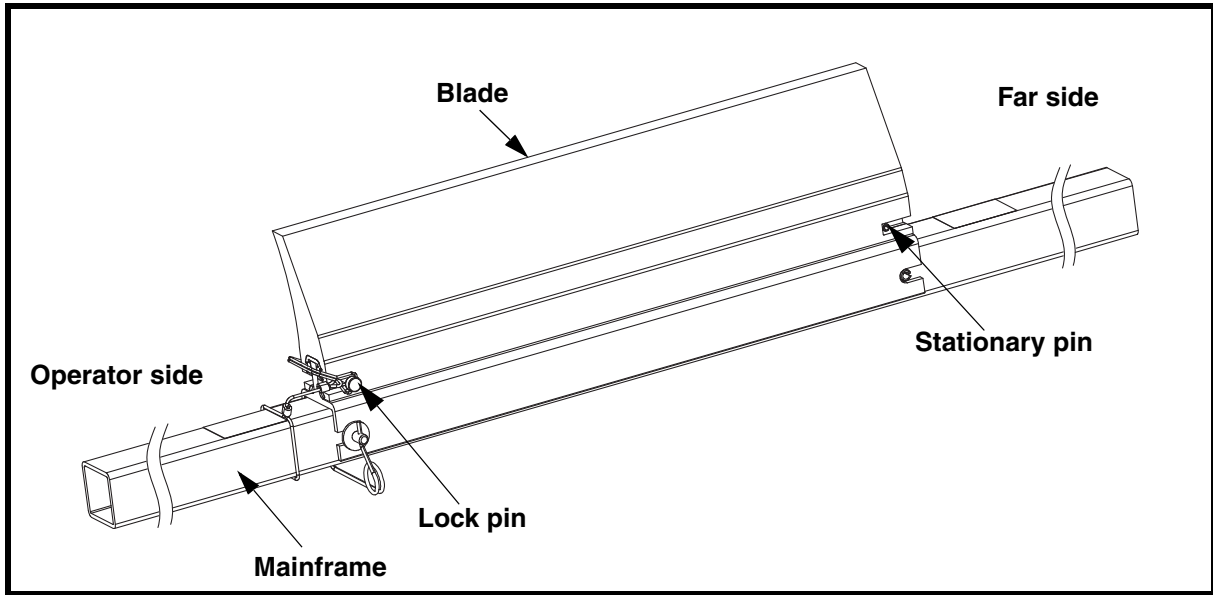

**Figure 2. Removing and Installing Blade**

***Removing blade***

1. Remove lock pin from operator side of mainframe and blade.
2. Pull blade away from stationary pin on far side of mainframe, and remove from mainframe. Make sure lock pin remains attached to mainframe.

***Installing tensioner***

1. Install tensioner according to *Martin® SQC2S™ Square Mainframe Tensioner Operator's Manual*, P/N M3815.
2. If using *Martin® Inspection Door*, install according to *Martin® Inspection Door Operator's Manual*, P/N M3891.

***Installing blade***

1. Slide blade onto mainframe with blade positioned as shown in Figure 1. Push far side end of blade against stationary pin until it locks.
2. Insert lock pin in mainframe.
3. Make sure blades are centered on belt and mainframe is parallel to belt.
4. Tension belt cleaner according to *Martin® SQC2S™ Square Mainframe Tensioner Operator's Manual*, P/N M3815.

# After Installing Belt Cleaner



1. Thoroughly wipe chute wall clean above tensioner.
2. Place Conveyor Products Warning Label (P/N 23395) on outside chute wall visible to belt cleaner operator.

## **⚠ WARNING**

Failure to remove tools from installation area and conveyor belt before turning on energy source can cause serious injury to personnel and damage to belt.

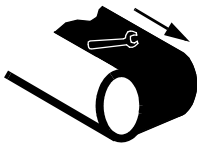

## **⚠ DANGER**

Do not touch or go near conveyor belt or conveyor accessories when conveyor belt is running. Body or clothing can get caught and pull body into conveyor belt, causing severe injury or death.



3. Turn on conveyor belt for 1 hour, then turn off.

## **⚠ DANGER**

Before installing, servicing, or adjusting the belt cleaner/tensioner, turn off and lock out/tag out all energy sources to the conveyor and conveyor accessories according to ANSI standards. Failure to do so could result in serious injury or death.



4. Make sure all fasteners are tight. Tighten if necessary.
5. Make sure cleaner is not changing belt line. If it is, install belt support ahead of blade-to-belt contact point (Secondary Cleaner).
6. Inspect belt cleaner for the following:
  - Wear. (A small amount of “break-in” wear may be found. This will stop once blades wear to conveyor belt contour.)
  - Material buildup. (No material between blades and return side of conveyor belt should be found.)
7. If wear, material buildup, or some other problem exists, see “Troubleshooting.”

# Weekly Maintenance

---

## IMPORTANT

Read entire section before beginning work.

## NOTE

Maintenance inspection should be performed no less than weekly. Some applications may require more frequent maintenance inspections.



## ⚠ DANGER

Before installing, servicing, or adjusting the belt cleaner/tensioner, turn off and lock out/tag out all energy sources to the conveyor and conveyor accessories according to ANSI standards. Failure to do so could result in serious injury or death.

1. Remove any material from belt cleaner.
2. Make sure all fasteners are tight. Tighten if necessary.
3. Check tension on cleaner. Re-tension if necessary.
4. Wipe all labels clean. If labels are not readable, contact Martin Engineering or a representative for replacements.
5. Check blades for excessive wear. Replace if necessary.
6. Remove equipment from service if there is any indication it is not functioning properly. Call Martin Engineering or a representative for assistance. Do NOT return equipment to operation until the cause of the problem has been identified and corrected.

## ⚠ WARNING

Failure to remove tools from installation area and conveyor belt before turning on energy source can cause serious injury to personnel and damage to belt.

7. Remove all tools from maintenance area.

## ⚠ DANGER

Do not touch or go near conveyor belt or conveyor accessories when conveyor belt is running. Body or clothing can get caught and pull body into conveyor belt, causing severe injury or death.

8. Start conveyor belt.

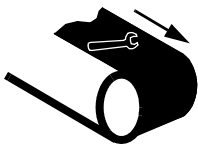

# Troubleshooting

| Symptom  | Corrective Action   |
|--|---|
| Insufficient cleaning and carryback.                                     | <ul style="list-style-type: none"> <li>Tension of cleaner on belt is set too low or too high. Increase or decrease tensioner setting.</li> <li>Blades are worn. Check blades and replace if necessary.</li> </ul> |
| Noise or vibration.  | Tension is not sufficient or is set too high. Correct tension as necessary. If this does not correct problem, blade urethane may not match application. Contact Martin Engineering or representative.             |
| High blade wear rate.  | Tension of cleaner on belt is set too high. Reduce tensioner setting.   |
| Unusual wear or damage to blades.  | Check belt splice(s) and repair as necessary.   |
| Bent or broken mainframe or support frame due to blade slipping through. | If blades are worn to or past the wear line, replace blades. If blades are not worn, check mainframe location.  |
| Corrosion or chemical degradation.                                       | Blade urethane may not match application. Contact Martin Engineering or representative.   |

## NOTE

Conveyor equipment such as conveyor belt cleaners are subject to a wide variety of bulk materials characteristics and often have to perform under extreme operating or environmental conditions. It is not possible to predict all circumstances that may require troubleshooting. Contact Martin Engineering or a representative if you are experiencing problems other than those listed in the “Troubleshooting” chart above. Do not return the equipment to operation until the problem has been identified and corrected.

### ***Installation checklist***

If after taking the corrective actions suggested under “Troubleshooting” you are still experiencing problems, check for the following:

| Installation Checklist   |
|--|
| ✓ Pre-Cleaner mainframe is proper distance from belt surface on both ends of mainframe.                            |
| ✓ Pre-Cleaner blade tip is at or below horizontal center line of pulley and does not lie in path of material flow. |
| ✓ Secondary Cleaner is not changing belt line.   |
| ✓ Blades are centered on belt.   |

## Part Numbers

---

This section provides product names and corresponding part numbers for Martin® H2O Cleaners and related equipment. Please reference part numbers when ordering parts:

### ***Martin® H2O Cleaner***

**Martin® H2O Cleaner Assembly:** P/N H2O4000S-XXXX. See Figure 3.

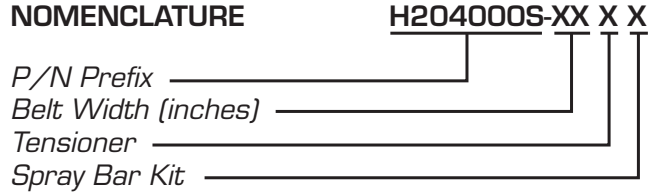

**TENSIONER**

**T:** With Tensioner  
**Ø:** Without Tensioner

**SPRAY BAR KIT**

**W:** With Spray Bar Kit  
**Ø:** Without Spray Bar Kit

### ***Martin® H2O Blade Cartridge***

**Martin® H2O Blade Cartridge:** P/N H2O-XX-C.

### ***Martin® SQC2S™ Tensioners***

**Martin® SQC2S™ Tensioners:** P/N 38664.

### ***Miscellaneous***

**Martin® Heavy-Duty Hanger Mount Assembly:** P/N 34233-HD. Used to mount Martin® SQC2S™ Tensioners onto stringer instead of onto chute wall.

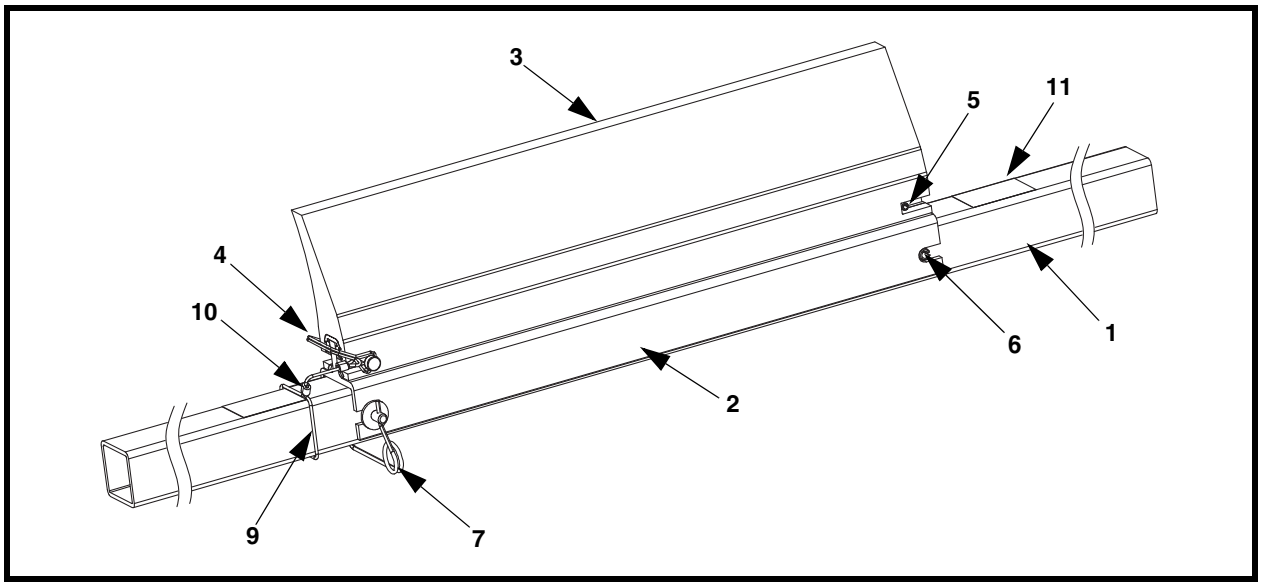

**Figure 3. Martin® H2O Cleaner Assembly, P/N H2O4000S-XXXX**

| Item | Description                     | Part Number | Qty. |
|------|---------------------------------|-------------|------|
| 1    | Mainframe                       | 38657-XXEX* | 1    |
| 2    | Blade Cartridge                 | H2O-XX-C**  | 1    |
| 3    | Blade                           | Table II    | 1    |
| 4    | Pin Wire Lock 1/4 x 2-1/2       | 32772       | 1    |
| 5    | Pin Slotted Spring 5/16 x 2 ZP  | 32774       | 1    |
| 6    | Pin Slotted Spring 1/2 x 3 ZP   | 33840       | 1    |
| 7    | Pin Snap Lock 7/16              | 33841       | 1    |
| 8    | Tensioner Assembly              | 38664       | 1    |
| 9    | Rope Wire 1/8 SS                | 100107      | 3    |
| 10   | Cable Clip for 1/8 Dia. Cable   | 23481       | 4    |
| 11   | Label Martin Products           | 38048       | 2    |
| 12   | Label Conveyor Products Warning | 23395       | 2    |
| 13   | Manual Operator's               | M3825       | 1    |
| 14   | Spray Bar Kit                   | 34879-XXS** | 1    |

\* First XX indicates belt width. Last X indicates material: mild steel (Blank) or stainless steel (S).

\*\* XX indicates belt width.

**Table II. Martin® H2O Cleaner Assembly Part Numbers**

| <b>Assembly Part No.</b> | <b>P/N Item 3</b> |
|--------------------------|-------------------|
| H2O4000S-18XX            | H2O4001-181116    |
| H2O4000S-24XX            | H2O4001-241122    |
| H2O4000S-30XX            | H2O4001-301128    |
| H2O4000S-36XX            | H2O4001-361134    |
| H2O4000S-42XX            | H2O4001-421140    |
| H2O4000S-48XX            | H2O4001-481146    |
| H2O4000S-54XX            | H2O4001-541152    |
| H2O4000S-60XX            | H2O4001-601158    |
| H2O4000S-66XX            | H2O4001-661164    |
| H2O4000S-72XX            | H2O4001-721170    |
| H2O4000S-84XX            | H2O4001-841182    |

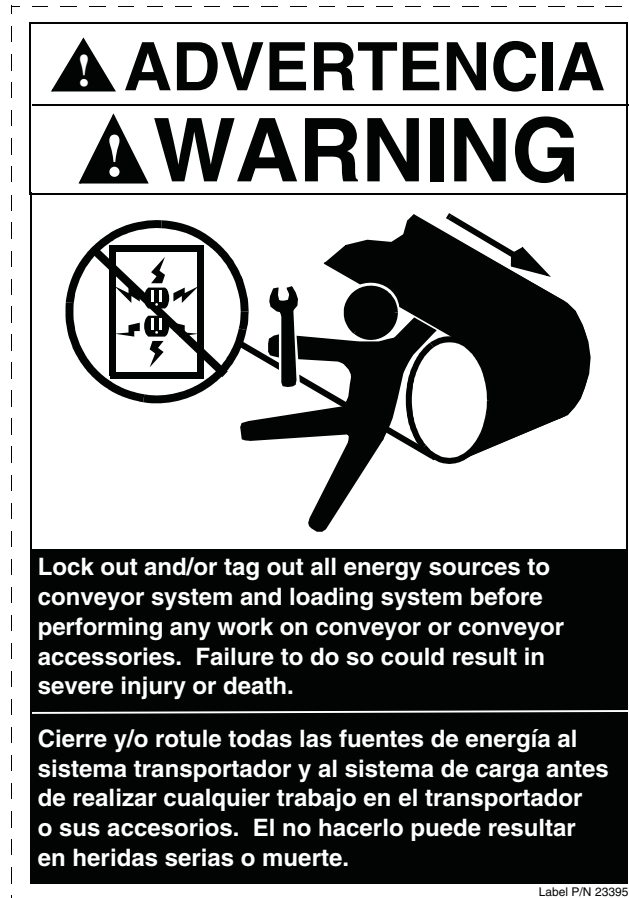
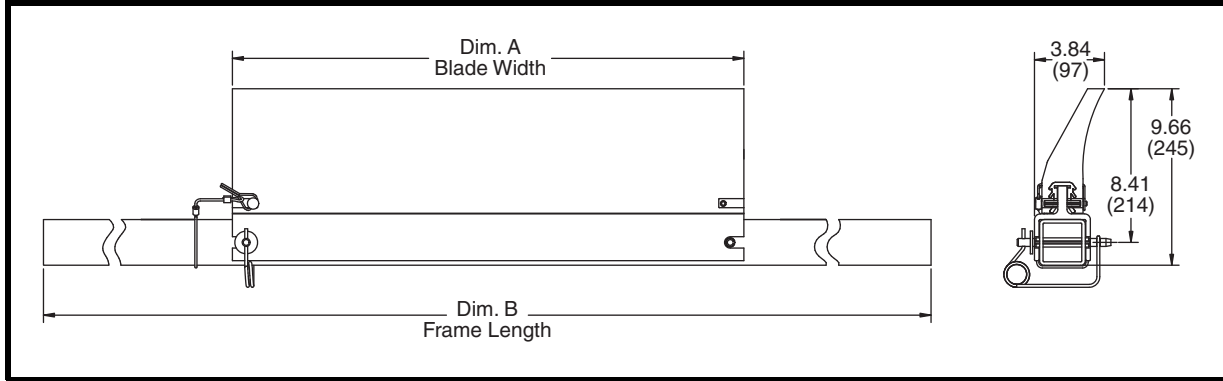

**Figure 4. Conveyor Products Warning Label, P/N 23395**



# Appendix

## Martin® H2O Cleaner Assembly Dimensions



| Part No.      | Dim "A"<br>Blade Width | Dim "B"<br>Mainframe Length |
|---------------|------------------------|-----------------------------|
| H2O4000S-18XX | 16.00 (406)            | 66.00 (1676)                |
| H2O4000S-24XX | 22.00 (559)            | 72.00 (1829)                |
| H2O4000S-30XX | 28.00 (711)            | 78.00 (1981)                |
| H2O4000S-36XX | 34.00 (864)            | 84.00 (2134)                |
| H2O4000S-42XX | 40.00 (1016)           | 90.00 (2286)                |
| H2O4000S-48XX | 46.00 (1168)           | 96.00 (2438)                |
| H2O4000S-54XX | 52.00 (1321)           | 102.00 (2591)               |
| H2O4000S-60XX | 58.00 (1473)           | 108.00 (2743)               |
| H2O4000S-66XX | 64.00 (1626)           | 114.00 (2896)               |
| H2O4000S-72XX | 70.00 (1778)           | 120.00 (3048)               |
| H2O4000S-84XX | 82.00 (2083)           | 132.00 (3353)               |

## Notes

*Any product, process, or technology described here may be the subject of intellectual property rights reserved by Martin Engineering Company. Trademarks or service marks designated with the ® symbol are registered with the U.S. Patent and Trademark Office and may be proprietary in one or more countries or regions. Other trademarks and service marks belonging to Martin Engineering Company in the United States and/or other countries or regions may be designated with the “TM” and “SM” symbols. Brands, trademarks, and names of other parties, who may or may not be affiliated with, connected to, or endorsed by Martin Engineering Company, are identified wherever possible. Additional information regarding Martin Engineering Company’s intellectual property can be obtained at [www.martin-eng.com/trademarks](http://www.martin-eng.com/trademarks).*

# Problem Solved™ GUARANTEED!

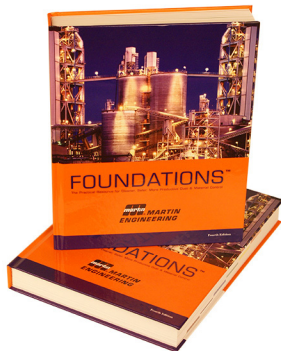

*For nearly 20 years, Martin Engineering's Foundations™ Books have taught industry personnel to operate and maintain clean and safe belt conveyors. The Foundations™ Book, fourth edition, focuses on improving belt conveyors by controlling fugitive material. "The Practical Resource for Total Dust and Material Control," is a 576-page hard cover volume that provides information of value to industries where the efficient handling of bulk materials is a key to productivity and profitability.*

*Expanding upon the book, our Foundations™ Training Program addresses the design and development of more productive belt conveyors, and is offered in three customizable seminars. Attendees gain a better understanding of conveyor safety and performance, helping to justify upgrade investments and increase profitability.*



## **Martin Engineering USA**

One Martin Place  
Neponset, IL 61345-9766 USA  
800 544 2947 or 309 852 2384  
Fax 800 814 1553  
[www.martin-eng.com](http://www.martin-eng.com)

**COMPANY WITH  
QUALITY SYSTEM  
CERTIFIED BY DNV  
= ISO 9001:2008 =**