

ITEM	QTY.	DESCRIPTION	PART NUMBER
1	1	MARTIN® QC™ #1 XHD ASSEMBLY	SEE CHART
2	1	MARTIN® XHD AIR TENSIONER	33894-2R

MOUNTING LOCATION CHART	
DIM 'C'	DIM 'D'
HEAD PULLEY DIAMETER *	
16 [400]	5.75 [146]
20 [500]	5.50 [140]
24 [600]	5.25 [133]
28 [700]	5.00 [127]
30-120 [750-3000]	4.75 [120]

* INCLUDES BELT & LAGGING

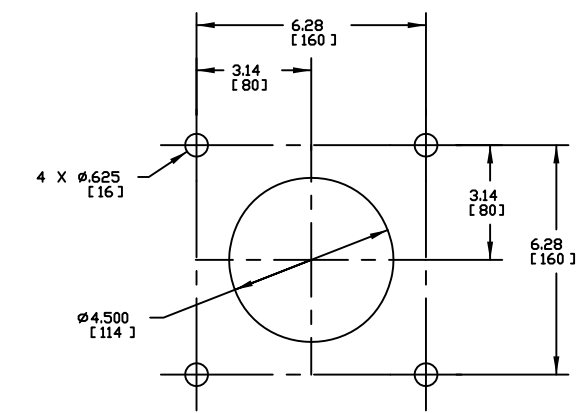

TENSIONER CHUTE CUTOUT DETAIL
SCALE 3/8
TYPICAL BOTH SIDES

PART NUMBER	DIM 'A' MAX FRAME LENGTH	DIM 'B' BLADE LENGTH
35899-48XX36XXX	96.00 [2438]	36.00 [2438]
35899-48XX42XXX	96.00 [2438]	42.00 [2438]
35899-54XX42XXX	102.00 [2591]	42.00 [2591]
35899-54XX48XXX	102.00 [2591]	48.00 [2591]
35899-60XX48XXX	108.00 [2743]	48.00 [2743]
35899-60XX54XXX	108.00 [2743]	54.00 [2743]
35899-66XX54XXX	114.00 [2896]	54.00 [2896]
35899-66XX60XXX	114.00 [2896]	60.00 [2896]
35899-72XX60XXX	120.00 [3048]	60.00 [3048]
35899-72XX66XXX	120.00 [3048]	66.00 [3048]

PART NUMBER	BLADE COLOR
35899-XXXXXX	ORANGE
35899-XXXXXXBR	BROWN
35899-XXXXXXCL	TAN
35899-XXXXXXGR	GREEN
35899-XXXXXXNB	NAVY BLUE
35899-XXXXXXYL *	YELLOW

* ONLY OFFERED IN SEGMENTED (10)

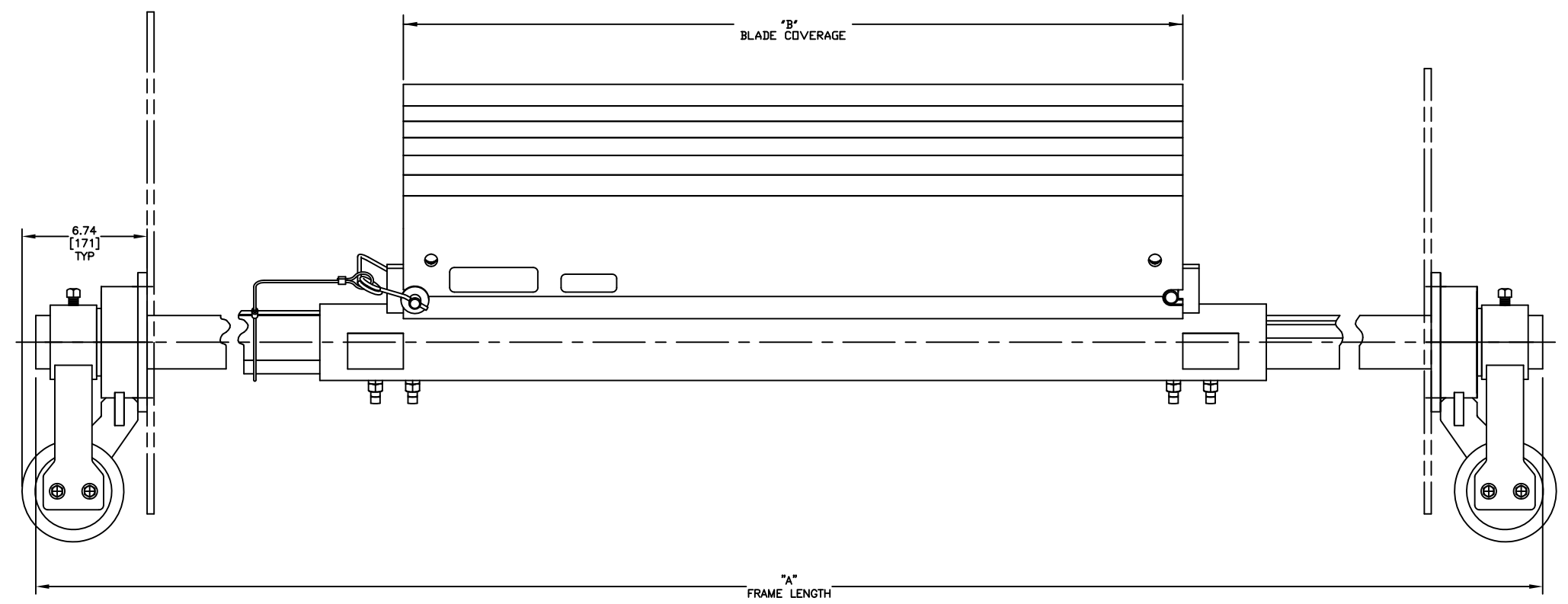
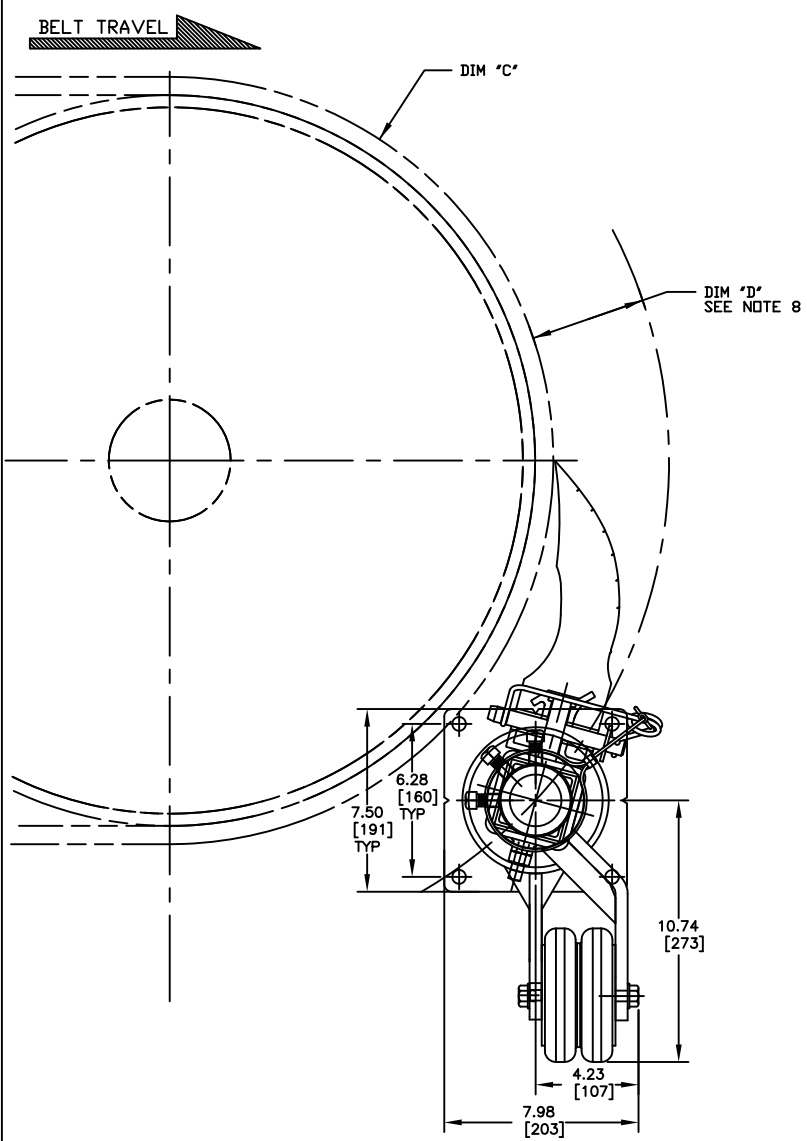

- NOTES:
- 1) ALL DIMENSIONS ARE GIVEN IN INCHES [MM].
 - 2) ALL DIMENSIONS ARE FOR REFERENCE ONLY.
 - 3) FOR EASY ACCESSIBILITY AND MAINTENANCE, MARTIN ENGINEERING RECOMMENDS BOLTING CLEANER TO EXISTING STRUCTURE WHEN APPLICABLE.
 - 4) CLEANER IS SHOWN IN RECOMMENDED WORKING POSITION.
 - 5) WHERE EXTREME OR UNUSUAL CONDITIONS EXIST, OR SPECIAL MAINFRAME LENGTHS ARE REQUIRED CONTACT MARTIN ENGINEERING.
 - 6) REFER TO OPERATOR'S MANUALS M3504, & M3263 FOR COMPLETE INSTALLATION INSTRUCTIONS.
 - 7) FOR BELT WIDTHS 42.00 [1000-1200] AND SMALLER, MARTIN ENGINEERING RECOMMENDS USING A SINGLE SPRING LEVER SHOCK MOUNT TENSIONER.
 - 8) CLEANER CAN BE LOCATED ANYWHERE ALONG THE ARC, AS LONG AS THE MAINFRAME IS OUT OF MATERIAL TRAJECTORY AND THE BLADE TIPS ARE BELOW THE HORIZONTAL CENTERLINE OF THE HEAD PULLEY.
 - 9) THE XHD QC #1 PRE-CLEANER BLADES ARE DESIGNED TO REMOVE HEAVY CARRYBACK ONLY. DO NOT OVERTENSION.
 - 10) BLADE COVERAGE IS LESS THAN BELT WIDTH, DUE TO POSSIBLE MISTRACKING OR DAMAGED EDGES OF THE BELT.
 - 11) THE FIRST TWO XX'S OF THE CLEANER PART NUMBER INDICATE BELT WIDTH. THE THIRD X INDICATES SOLID (X) OR SLIT (O). THE NEXT X INDICATES SOLID (X) OR SEGMENTED (O). THE NEXT TWO XX'S INDICATE BLADE WIDTH. THE LAST TWO XX'S INDICATE BLADE COLOR/MATERIAL.
 - 12) EXAMPLE: 35899-481142BR (48.00 BELT WIDTH, 42.00 SOLID, BROWN BLADE).

©Copyright 2015 Martin Engineering. All rights reserved. Covered by U.S. and foreign patents pending and issued. R and TM indicate trademarks of Martin Engineering.

MARTIN ENGINEERING NEPONSET ILLINOIS USA

TITLE	MARTIN® QC™ #1 XHD PRE-CLEANER WITH DUAL XHD AIR TENSIONER	DRAWN	JAP
		DATE	03/05/15
		CHECKED	
		ENG.	
		DATE	
		APPROVED	
		DATE	
		SCALE	1/4

NO.	DESCRIPTION	ECN	DATE	BY
A	ADDED P/N 35899-XXXXXXYL TO "ONLY OFFERED IN SEGMENTED (10)" OPTION	15172	08/16/18	JAH

SALES DRAWING S36221-A