

PART NO.	BELT WIDTH	DIM "A" FRAME LENGTH	DIM "B" BLADE COVERAGE	AIR PRESSURE PSI [kPa]	TENSIONER P/N	
35899-18XX12XX	18.00	400-500	66.00 [1676]	12.00 [457]	18 [124]	32135
35899-24XX18XX	24.00	500-650	72.00 [1829]	18.00 [610]	19 [131]	32135
35899-30XX24XX	30.00	650-800	78.00 [1981]	24.00 [762]	26 [179]	32135
35899-36XX30XX	36.00	800-1000	84.00 [2134]	30.00 [914]	32 [221]	32135
35899-42XX36XX	42.00	1000-1200	90.00 [2286]	36.00 [1067]	38 [262]	32135
35899-48XX42XX	48.00	1200-1400	96.00 [2438]	42.00 [1067]	31 [214]	32135-2R
35899-54XX48XX	54.00	1400-1600	102.00 [2591]	48.00 [1219]	31 [214]	32135-2R
35899-60XX54XX	60.00	1600-1800	108.00 [2743]	54.00 [1372]	40 [276]	32135-2R
35899-66XX60XX	66.00	1600-1800	114.00 [2896]	60.00 [1524]	40 [276]	32135-2R
35899-72XX66XX	72.00	1800-2000	120.00 [3048]	66.00 [1676]	45 [310]	32135-2R

MOUNTING LOCATION CHART	
DIM "C" HEAD PULLEY DIAMETER *	DIM "D"
16 [400]	5.75 [146]
20 [500]	5.50 [140]
24 [600]	5.25 [133]
28 [700]	5.00 [127]
30-120 [750-3000]	4.75 [120]

* INCLUDES BELT AND LAGGING

ASSEMBLY PART NO.	COLOR
35899-XXXXXX	ORANGE
35899-XXXXXXBRX	BROWN
35899-XXXXXXCLX	CLEAR
35899-XXXXXXGRX	GREEN
35899-XXXXXXNBX	NAVY BLUE
35899-XXXXXXCYX	YELLOW W/BEADS
35899-XXXXXXYLX	YELLOW

ONLY OFFERED IN SEGMENTED (10)

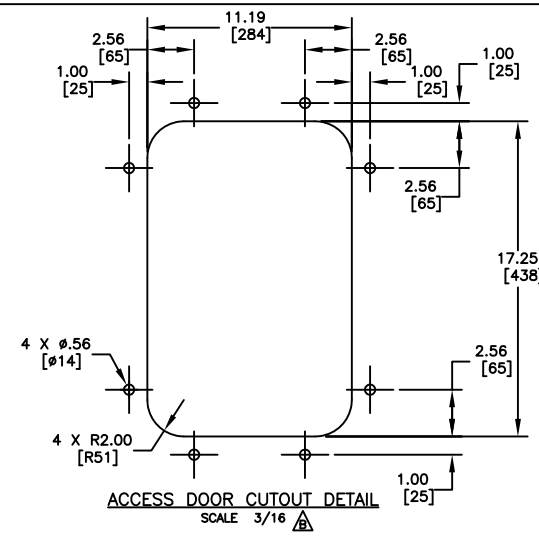
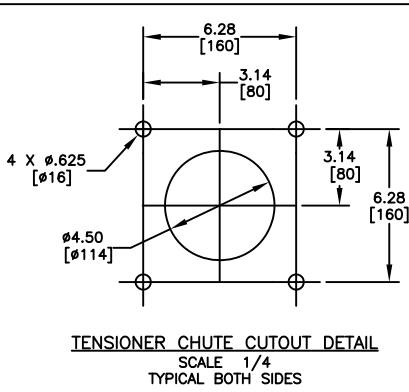

ITEM	QTY.	DESCRIPTION	PART NUMBER
1	1	MARTIN® QC™ #1 XHD CLEANER ASM	SEE CHART
2	1	MARTIN® XHD AIR CYLINDER TENSIONER	SEE CHART
3	1	MARTIN® LOW PROFILE ACCESS DOOR	CYA-1218

NOTES:
1) ALL DIMENSIONS ARE GIVEN IN INCHES [MM].
2) ALL DIMENSIONS ARE FOR REFERENCE ONLY.
3) FOR EASY ACCESSIBILITY AND MAINTENANCE, MARTIN ENGINEERING RECOMMENDS BOLTING CLEANER TO EXISTING STRUCTURE WHEN APPLICABLE.
4) CLEANER IS SHOWN IN RECOMMENDED WORKING POSITION.
5) WHERE EXTREME OR UNUSUAL CONDITIONS EXIST, OR SPECIAL MAINFRAME LENGTHS ARE REQUIRED CONTACT MARTIN ENGINEERING.
6) REFER TO OPERATOR'S MANUAL M3504 & M3512 FOR INSTALLATION INSTRUCTIONS.
7) FOR BELT WIDTHS 42.00 [1000-1200] AND SMALLER, MARTIN ENGINEERING RECOMMENDS USING A SINGLE AIR CYLINDER TENSIONER.
8) CLEANER CAN BE LOCATED ANYWHERE ALONG THE ARC, AS LONG AS THE MAINFRAME IS OUT OF MATERIAL TRAJECTORY AND THE BLADE TIPS ARE BELOW THE HORIZONTAL CENTERLINE OF THE HEAD PULLEY.
9) THE QC#1 XHD PRE-CLEANER BLADES ARE DESIGNED TO REMOVE HEAVY CARRYBACK ONLY. DO NOT OVERTENSION.
10) BLADE COVERAGE IS LESS THAN BELT WIDTH, DUE TO POSSIBLE MISTRACKING OR DAMAGED EDGES OF THE BELT.
11) FIRST TWO XX'S INDICATE BELT WIDTH, THE THIRD X INDICATES SOLID (1) OR SLIT (0) BLD. THE FOURTH X INDICATES SOLID (1), SEGMENTED FULL LG (0), OR SEGMENTED AT ENDS ONLY (2) BLD. THE NEXT TWO XX'S INDICATE BLADE COLOR/MATERIAL.
EXAMPLE:
35899-4800 = 48" BELT, SLIT AND SEGMENTED ORANGE BLD
35899-3610BR = 36" BELT, SEGMENTED BROWN BLADE.

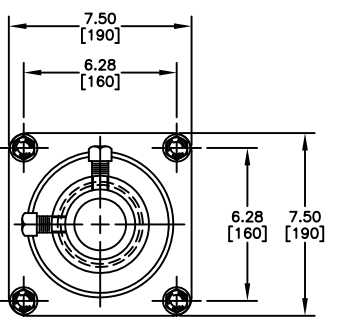
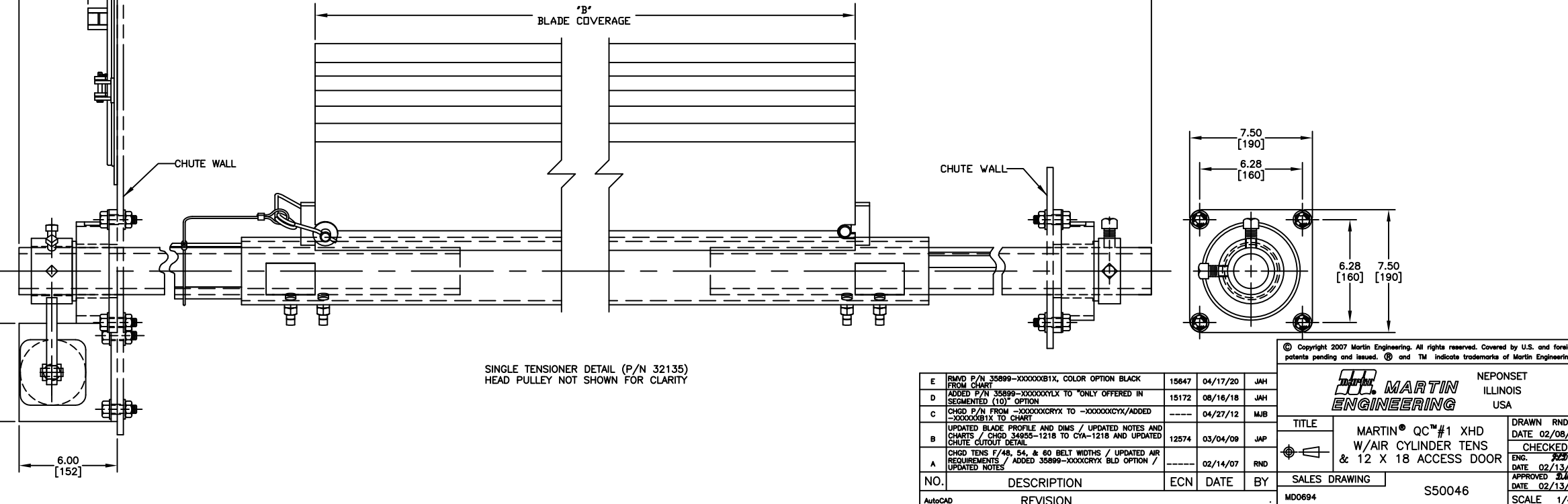
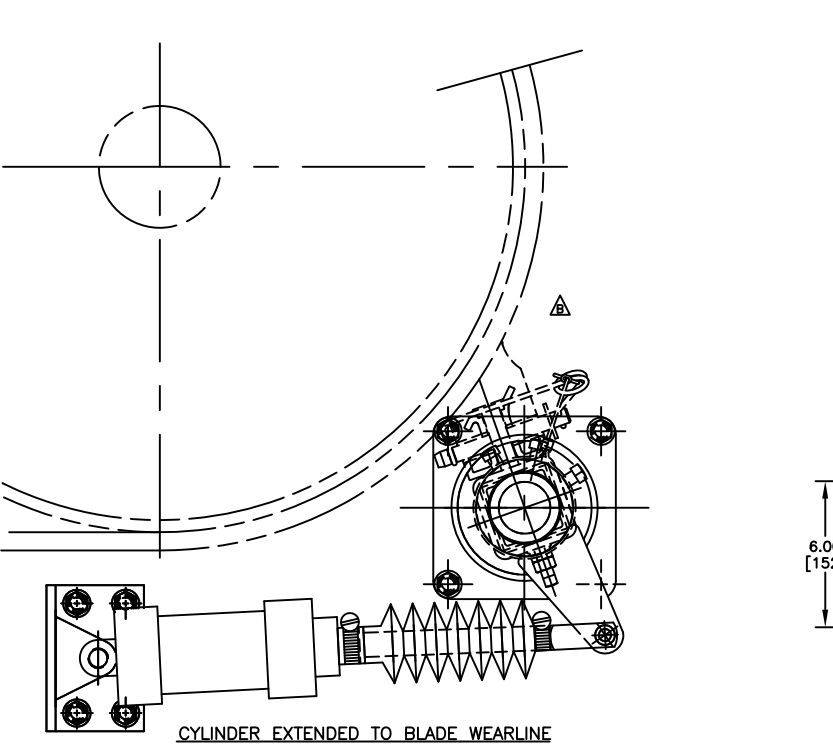
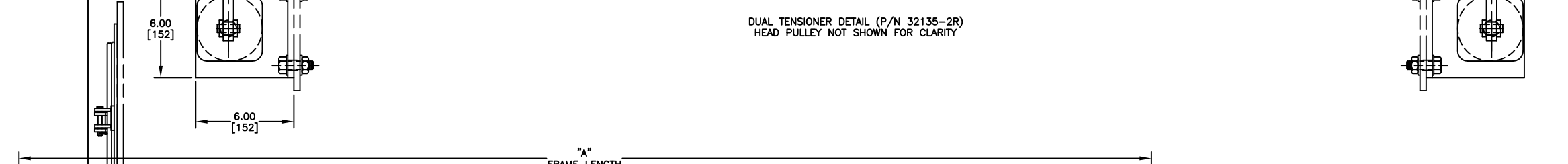
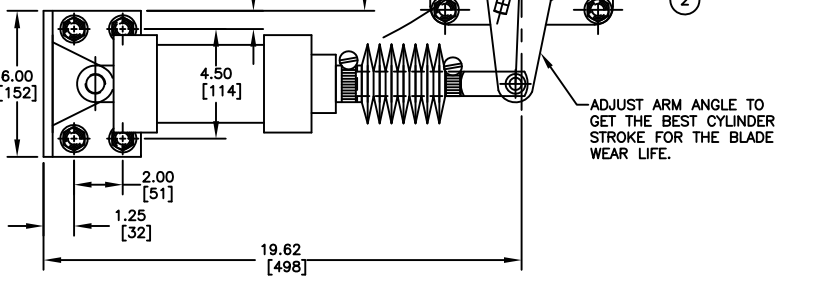
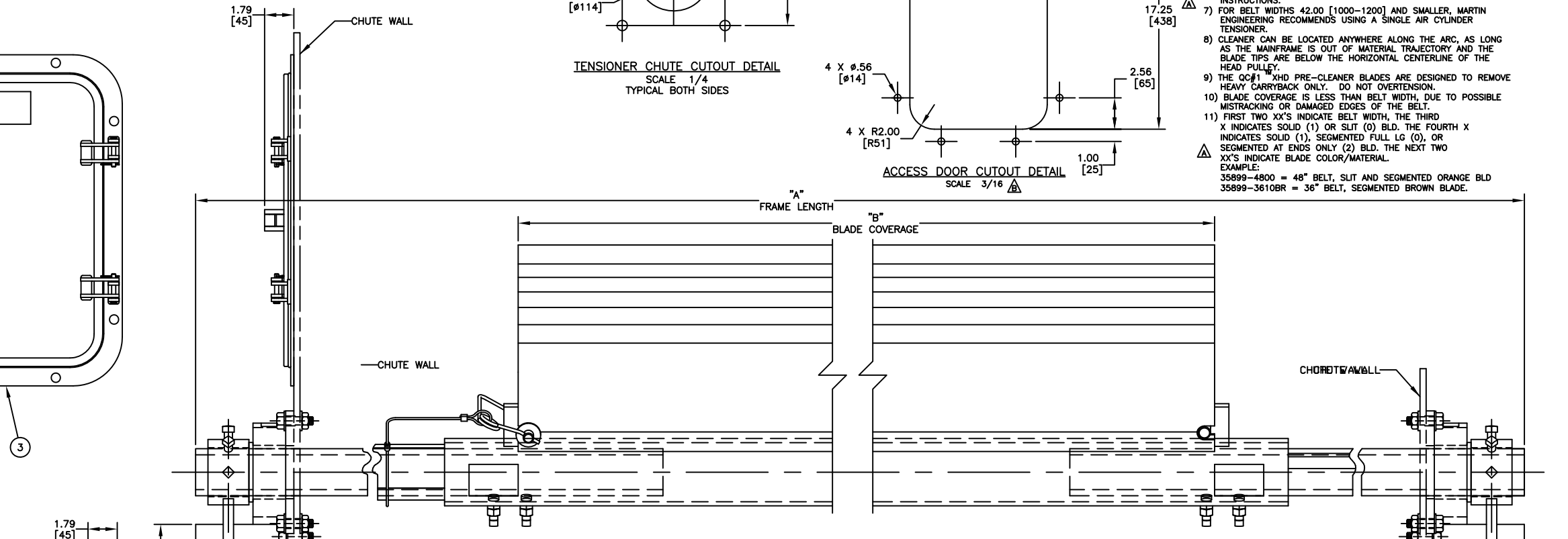
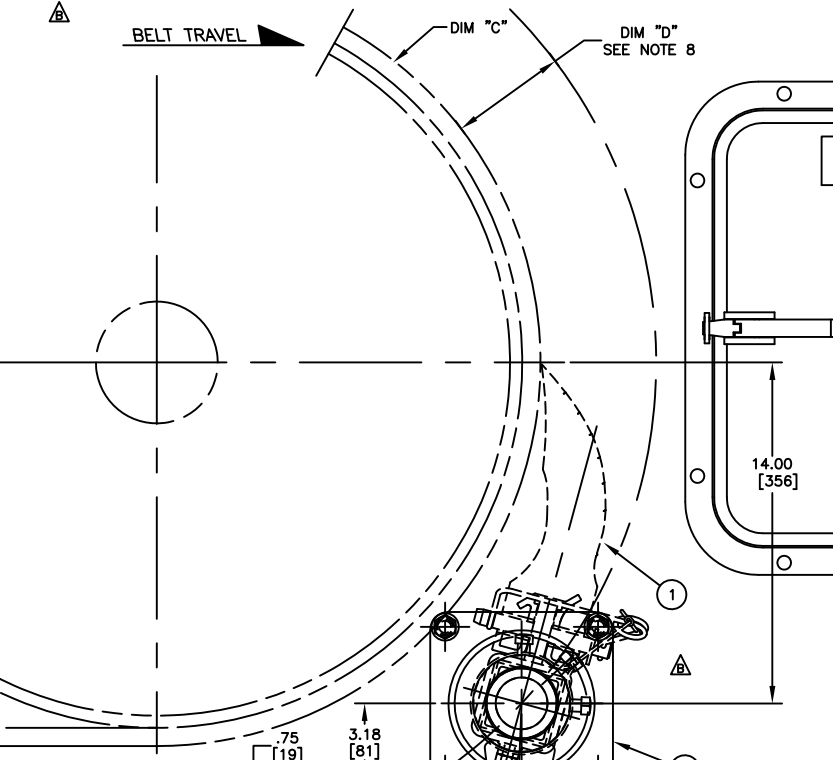

NO.	DESCRIPTION	ECN	DATE	BY
E	RWD P/N 35899-XXXXXXB1X, COLOR OPTION BLACK FROM CHART	15647	04/17/20	JMH
D	ADDED P/N 35899-XXXXXXYLX TO "ONLY OFFERED IN SEGMENTED (10)" OPTION	15172	08/16/18	JMH
C	CHGD P/N FROM -XXXXXXRYX TO -XXXXXXCYX/ADDED -XXXXXXB1X TO CHART	-----	04/27/12	MJB
B	UPDATED BLADE PROFILE AND DIMS / UPDATED NOTES AND CHARTS / CHGD 34985-1218 TO CYA-1218 AND UPDATED CHUTE CUTOUT DETAIL	12574	03/04/09	JAP
A	CHGD TENS F/48, 54, & 60 BELT WIDTHS / UPDATED AIR REQUIREMENTS / ADDED 35899-XXXXXXRYX BLD OPTION / UPDATED NOTES	-----	02/14/07	RND

AutoCAD REVISION

© Copyright 2007 Martin Engineering. All rights reserved. Covered by U.S. and foreign patents pending and issued. ® and TM indicate trademarks of Martin Engineering.

MARTIN ENGINEERING NEPONSET ILLINOIS USA

TITLE	MARTIN® QC™ #1 XHD W/AIR CYLINDER TENS & 12 X 18 ACCESS DOOR	DRAWN RND	DATE 02/08/07
SALES DRAWING	S50046	CHECKED	DATE 02/13/07
APPROVED		APPROVED	DATE 02/13/07
MDD0694		SCALE	1/4