

Martin® Vibroller™ Roller Vibrators

The Martin® Vibroller™ Roller Vibrators features a roller that produces ten vibrations for each revolution inside the cylinder case. This design principle of operation drastically reduces the wear factor. Available in sizes and styles to meet any job.

Tapped inlet and exhaust ports for complete air control. Exhaust air can be piped from the area or muffled. Quiet power for effective vibration.

ARL Series

Small and lightweight to fill a multitude of application needs. Maximum VPM ranges from 19,000 to 26,000 with power to handle bins with material in excess of 2,000 pounds in the sloped portion. This unique dual-mount bracket offers a wide choice of mount position and vibration direction.

ARF Series

Available in two sizes, both with a two-hole mount. Frequency range is from 8,000-26,000 vpm, developing a maximum of 540 pounds of force. The ARF Series can be matched to containers with up to 5,400 pounds of material in the sloped portion.

ARU Series

Available in a wide range of sizes to meet a multitude of applications needs. With forces to 3,000 pounds, this vibrator is capable of moving material in bins with up to 30,000 pounds in the sloped portion.



SPECIFICATIONS

Model	P/N Assembly	Unbalance lb-in.	Test	
			VPM**	db*
ARF-10	ARF-10M	0.003	18,200	85
ARF-19	ARF-19M	0.05	13,500	85
ARL-10	ARL-10M	0.003	18,200	85
ARL-13	ARL-13M	0.008	22,000	85
ARL-16	ARL-16M	0.02	13,300	85
ARU-19	ARU-19M	0.05	13,500	85
ARU-38	ARU-38M	0.5	7350	85
ARU-55	ARU-55M	0.5	7350	85
ARU-82	ARU-82M	2.0	4900	85
ARU-88	ARU-88M	0.8	6400	85

* Decibels measured with muffler connected to exhaust port and vibrator securely mounted on test block.

** Vibrations per minute (VPM) represents highest speed vibrator can attain and produce 85 db or less. (Note: Test is a comparison of vibrators. Levels will vary with each application.)

ACCESSORIES

Part Number	Description
See Chart	Channel Mount Kit
39504	Control Line Kit
14824-PR	Ball Valve 1/2" NPT
14760-PR	Filter, Regulator, Lubricator Combination, 1/2" NPT
14766	Air Motor Oil (qt)
38902-20	On/Off Cycle Timer 115/1/60
36343-NC	Solenoid Valve 115/1/60, 1/2" NPT

Model	Channel Mount Kit Part Number
ARF-10	220691-3-313
ARF-19	220691-4-375
ARU-19	
ARU-38	220691-6-625
ARU-55	220691-5-500
ARU-82	220691-8-750
ARU-88	

TECHNICAL DATA SHEET

PERFORMANCE DATA

Model	40 psi (2.76 bar)			60 psi (4.14 bar)			80 psi (5.51 bar)			Max lb material in slope of bin*
	vpm	Force lb (kg)	cfm (L/min)	vpm	Force lb (kg)	cfm (L/min)	vpm	Force lb (kg)	cfm (L/min)	
ARF-10	23,000	45 (20)	2 (57)	25,000	53 (24)	2 (57)	26,000	58 (26)	4 (113)	580
ARF-19	11,000	172 (78)	5 (142)	14,500	299 (136)	10 (283)	19,500	540 (245)	14 (396)	5400
ARL-10	23,000	45 (20)	2 (57)	25,000	53 (24)	2 (57)	26,000	58 (26)	4 (113)	580
ARL-13	22,000	110 (50)	2 (57)	24,000	131 (59)	4 (113)	25,000	142 (64)	6 (170)	1420
ARL-16	13,500	104 (47)	3 (85)	17,000	164 (74)	5 (142)	19,000	205 (93)	7 (198)	2050
ARU-19	11,000	172 (78)	5 (142)	14,500	299 (136)	10 (283)	19,500	540 (245)	14 (396)	5400
ARU-38	8000	910 (413)	15 (425)	10,000	1421 (645)	21 (595)	10,500	1566 (710)	29 (821)	15,200
ARU-55	8000	910 (413)	15 (425)	10,000	1421 (645)	21 (595)	10,500	1566 (710)	29 (821)	15,200
ARU-82	5600	1782 (808)	35 (991)	6150	2150 (975)	46 (1303)	7000	2785 (1263)	60 (1699)	28,000
ARU-88	10,000	2273 (1031)	40 (1133)	10,500	2506 (1137)	46 (1303)	11,500	3006 (1364)	52 (1473)	30,000

* **Rule-of-thumb vibrator sizing:** One pound of vibrator force for every ten pounds of product in the sloped section of the bin content. Mount vibrator as close as possible to material outlet. Reinforce mount area to prevent flexure of bin wall at mount location.

DIMENSIONS—IN. (MM)

Model	A	B	C	D	E	F	G	Bolt Size H	J	NPT K	L	M
ARF-10	3.88 (98.4)	2.11 (53.6)	1.95 (49.6)	1.25 (31.8)	1.13 (28.6)	3.0 (76.2)	0.23 (5.7)	5/16	1.00 (25.4)	1/8	0.63 (15.9)	1.09 (27.8)
ARF-19	5.0 (127.0)	3.25 (82.6)	1.95 (49.6)	1.87 (47.6)	1.80 (45.7)	4.0 (101.6)	0.38 (9.5)	3/8	1.37 (34.9)	1/4	2.68 (68.0)	1.87 (47.5)
ARL-10	3.14 (79.7)	1.97 (50.1)	1.95 (49.6)	1.25 (31.8)	0.56 (14.3)	1.37 (34.9)	0.34 (8.6)	5/16	1.07 (27.3)	1/8	1.12 (28.6)	—
ARL-13	3.64 (92.5)	2.28 (58.0)	1.95 (49.6)	1.50 (38.1)	0.63 (16.1)	1.56 (39.7)	0.38 (9.6)	3/8	1.20 (30.5)	1/8	1.25 (31.8)	—
ARL-16	4.37 (111.1)	2.92 (74.3)	1.95 (49.6)	1.81 (46.0)	0.88 (22.2)	2.06 (52.4)	0.44 (11.2)	3/8	1.46 (37.0)	1/4	1.75 (44.5)	—
ARU-19	5.0 (127.0)	3.15 (80.0)	1.95 (49.6)	1.65 (41.9)	1.75 (44.5)	4.0 (101.6)	0.37 (9.5)	3/8	1.37 (34.9)	1/4	—	—
ARU-38	7.76 (197.0)	4.92 (125.0)	2.95 (75.0)	2.54 (64.5)	2.59 (65.7)	6.0 (152.4)	0.54 (13.7)	5/8	1.87 (47.6)	3/8	—	—
ARU-55	6.38 (162.0)	5.67 (144.0)	2.95 (75.0)	2.70 (68.6)	3.25 (82.6)	5.0 (127.0)	0.66 (16.7)	1/2	1.37 (34.9)	3/8	—	—
ARU-82	10.0 (254.0)	6.89 (175.0)	4.0 (101.5)	3.74 (95.0)	4.02 (102.1)	8.0 (203.2)	0.75 (19.1)	3/4	2.81 (71.4)	3/4	—	—
ARU-88	10.0 (254.0)	6.89 (175.0)	4.0 (101.5)	3.74 (95.0)	4.02 (102.1)	8.0 (203.2)	0.75 (19.1)	3/4	2.81 (71.4)	3/4	—	—

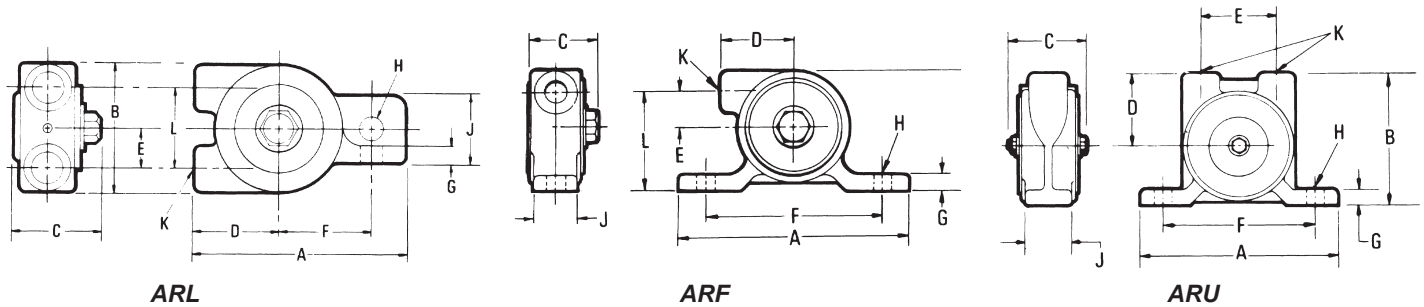

See the operator's manual for application information and mount selection.



Martin Engineering USA

3600 Cougar Drive
Peru, IL 61354 USA
855 394 4885
Fax 800 814 1553
www.martin-eng.com

**COMPANY WITH
QUALITY SYSTEM
CERTIFIED BY DNV
= ISO 9001:2008 =**

Problem Solved™ GUARANTEED!

Form No. L2731-11/19
© Martin Engineering Company 1997, 2019