

PART NO.	BELT WIDTH	DIM "A" BLADE WIDTH	DIM "B" MAX FRAME LENGTH
35899D72XX66XXX	72.00 [1800-2000]	66.00 [1676]	120.00 [3048]
35899D84XX72XXX	84.00 [2000-2200]	72.00 [1829]	132.00 [3353]
35899D84XX78XXX	84.00 [2000-2200]	78.00 [1981]	132.00 [3353]
35899D96XX84XXX	96.00 [2200-2400]	84.00 [2134]	144.00 [3658]
35899D96XX90XXX	96.00 [2200-2400]	90.00 [2286]	144.00 [3658]
35899D102XX96XXX	102.00 [2400-2600]	96.00 [2438]	150.00 [3810]
35899D114XX108XXX	114.00 [2700-2900]	108.00 [2743]	168.00 [4267]
35899D120XX114XXX	120.00 [2900-3000]	114.00 [2896]	168.00 [4267]

MOUNTING LOCATION CHART	
DIM "C" HEAD PULLEY DIAMETER *	DIM "D"
16 [400]	5.75 [146]
20 [500]	5.50 [140]
24 [600]	5.25 [133]
28 [700]	5.00 [127]
30-120 [750-3000]	4.75 [120]

* INCLUDES BELT AND LAGGING

ITEM	QTY.	DESCRIPTION	PART NUMBER
1	1	MARTIN® OC #1 XHD DUAL BLADE ASSEMBLY	SEE CHART
2	1	MARTIN® XHD SPRING TENSIONER	38003-2
3	2	MARTIN® LOW PROFILE ACCESS DOOR	CYA-1218

PART NUMBER	BLADE COLOR
35899DXXXXXX	ORANGE
35899DXXXXXXBRX	BROWN
35899DXXXXXXCLX	TAN
35899DXXXXXXGRX	GREEN
35899DXXXXXXNBX	NAVY BLUE
35899DXXXXXXYLX	YELLOW

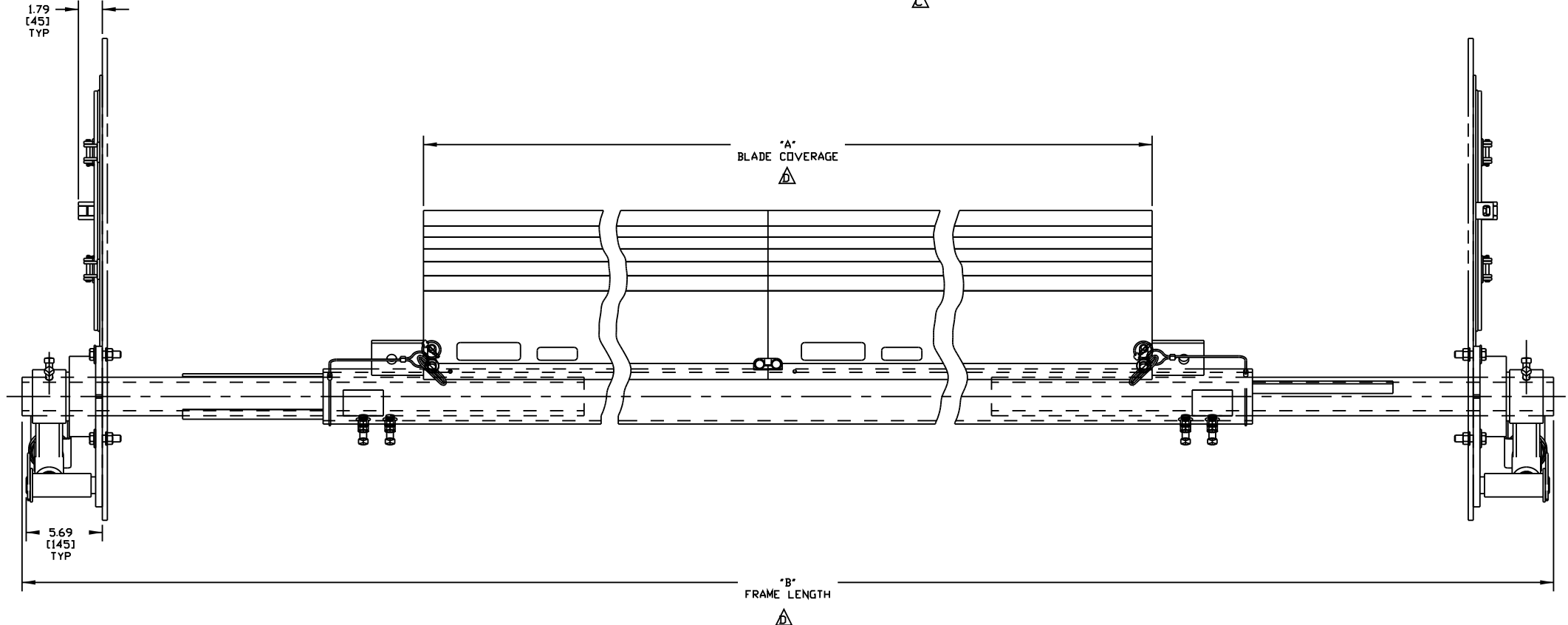
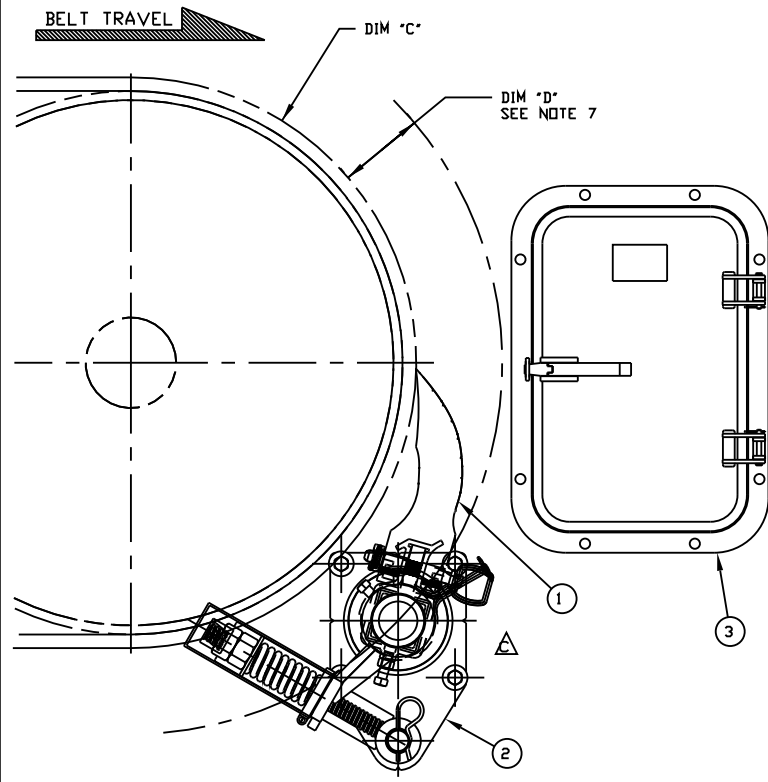
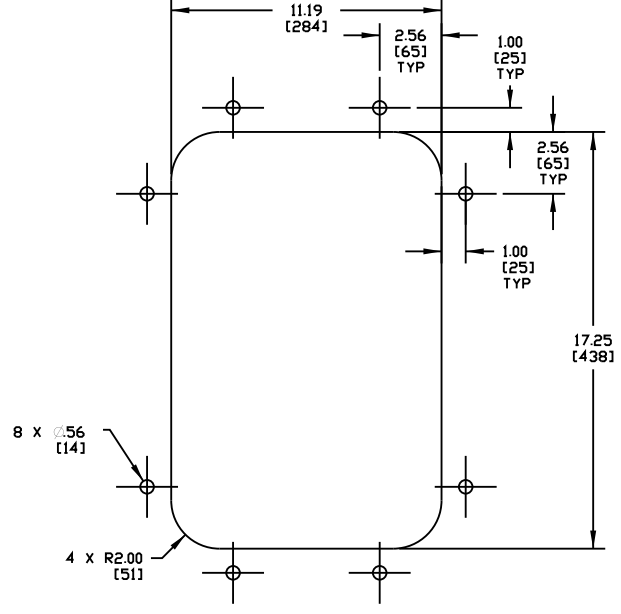
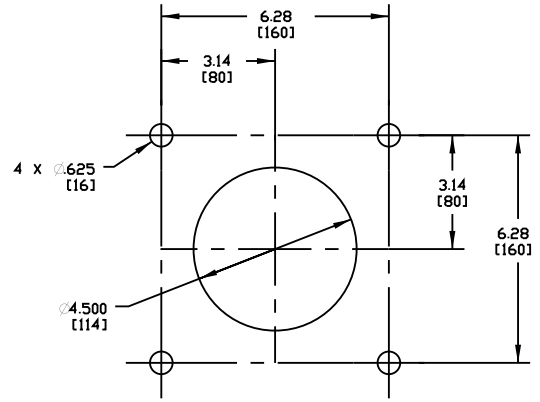

NOTES:

- ALL DIMENSIONS ARE GIVEN IN INCHES (MM).
- ALL DIMENSIONS ARE FOR REFERENCE ONLY.
- FOR EASY ACCESSIBILITY AND MAINTENANCE, MARTIN ENGINEERING RECOMMENDS BOLTING CLEANER TO EXISTING STRUCTURE WHEN APPLICABLE.
- CLEANER IS SHOWN IN RECOMMENDED WORKING POSITION.
- WHERE EXTREME OR UNUSUAL CONDITIONS EXIST, OR SPECIAL MAINFRAME LENGTHS ARE REQUIRED CONTACT MARTIN ENGINEERING.
- REFER TO OPERATOR'S MANUALS M3504 & M3127 FOR COMPLETE INSTALLATION INSTRUCTIONS.
- CLEANER CAN BE LOCATED ANYWHERE ALONG THE ARC, AS LONG AS THE MAINFRAME IS OUT OF MATERIAL TRAJECTORY AND THE BLADE TIPS ARE BELOW THE HORIZONTAL CENTERLINE OF THE HEAD PULLEY.
- THE XHD OC #1 PRE-CLEANER BLADES ARE DESIGNED TO REMOVE HEAVY CARRYBACK ONLY. DO NOT OVERTENSION.
- ONE FULL TURN OF THE TENSIONING NUT ON THE SPRING TENSIONER IS EQUAL TO .20 (5).
- BLADE COVERAGE IS LESS THAN BELT WIDTH, DUE TO POSSIBLE MISTRACKING OR DAMAGED EDGES OF THE BELT.
- THE FIRST THREE XXX'S OF THE CLEANER PART NUMBER INDICATE BELT WIDTH. THE NEXT X INDICATES SOLID (S) OR SLIT (L). THE NEXT X INDICATES SOLID (S) OR SEGMENTED (O). THE NEXT TWO XX'S INDICATE BLADE WIDTH. THE NEXT X'S INDICATE BLADE COLOR/MATERIAL. THE LAST X INDICATES IF A TENSIONER (T) IS INCLUDED.
EXAMPLE: 35899D841172BR = 84.00 BELT, 72.00 SOLID BROWN BLADE.
35899D84107BT = 84.00 BELT, 78.00 SEGMENTED ORANGE BLADE, WITH TENSIONER.

NO.	DESCRIPTION	ECN	DATE	BY
D	UPDATED DIM'S "A" AND "B" IN DRAWING TO MATCH DIM'S "A" AND "B" IN THE CHART / ADDED MORE PART NUMBERS TO THE CHART	12989	01/19/11	RND
C	UPDATED BLADE PROFILE AND DIMS / UPDATED NOTES AND CHARTS / CHGD 34995-1218 TO CYA-1218 AND UPDATED CHUTE CUTOUT DETAIL	12574	03/03/09	JAP
B	CHGD P/N FROM 35392-2 TO 38003-2	11608	06/07/06	MJB
A	ADDED & ROUTED P/N -72XXXXXX (PR09781)	----	06/14/04	JAP

Copyright 2016 Martin Engineering. All rights reserved. Covered by U.S. and Foreign patents pending and issued. R and TM indicate trademarks of Martin Engineering.

MARTIN ENGINEERING
NEPONSET, IL USA

TITLE	MARTIN® XHD OC #1 DUAL BLADE CLEANER W/XHD SPRING TENSIONER AND 12 X 18 ACCESS DOOR	DRAWN	MJB
DATE	06/17/04	CHECKED	
ENG.	JAP	DATE	06/17/04
APPROVED	JRB	DATE	06/17/04
SCALE	3/16		

SALES DRAWING
M00611 S36067-D

