



Martin[®] **Inspection Door**

[Go to Martin[®] Inspection Door web page](#)



Operator's Manual
M3891

Important

MARTIN ENGINEERING HEREBY DISCLAIMS ANY LIABILITY FOR: DAMAGE DUE TO CONTAMINATION OF THE MATERIAL; USER'S FAILURE TO INSPECT, MAINTAIN AND TAKE REASONABLE CARE OF THE EQUIPMENT; INJURIES OR DAMAGE RESULTING FROM USE OR APPLICATION OF THIS PRODUCT CONTRARY TO INSTRUCTIONS AND SPECIFICATIONS CONTAINED HEREIN. MARTIN ENGINEERING'S LIABILITY SHALL BE LIMITED TO REPAIR OR REPLACEMENT OF EQUIPMENT SHOWN TO BE DEFECTIVE.

Observe all safety rules given herein along with owner and Government standards and regulations. Know and understand lockout/tagout procedures as defined by American National Standards Institute (ANSI) z244.1-1982, *American National Standard for Personnel Protection - Lockout/Tagout of Energy Sources - Minimum Safety Requirements* and Occupational Safety and Health Administration (OSHA) Federal Register, Part IV, 29 CFR Part 1910, *Control of Hazardous Energy Source (Lockout/Tagout); Final Rule*.

The following symbols may be used in this manual:



Danger: Immediate hazards that will result in severe personal injury or death.



Warning: Hazards or unsafe practices that could result in personal injury.



Caution: Hazards or unsafe practices that could result in product or property damages.



Important: Instructions that must be followed to ensure proper installation/operation of equipment.



Note: General statements to assist the reader.

Table of Contents

Section	Page
List of Figures and Tables	ii
Introduction	1
General	1
Martin [®] Inspection Door materials	1
References	1
Safety	1
Materials required	1
Before Installing Martin [®] Inspection Door	2
Installing Martin [®] Inspection Door	3
Martin [®] Rubber Inspection Door	3
Martin [®] Steel Inspection Door	4
Martin [®] Inspection Door with Barrier Guard	7
Martin [®] Round Urethane Inspection Door	8
After Installing Martin [®] Inspection Door	9
Weekly Maintenance	9
Part Numbers	10
Appendix A. Martin [®] Inspection Door Labels	A-1
Appendix B. Martin [®] Inspection Door Dimensions	B-1

List of Figures

Figure	Title	Page
1	Installing Martin [®] Inspection Door	3
2	Installing Martin [®] Steel Inspection Door	4
3	Installing Martin [®] Inspection Door With Barrier Guard	6
4	Installing Martin [®] Round Urethane Inspection Door.....	8
5	Martin [®] Rubber Inspection Door Assemblies, P/N CYAR-XXXXXXXX	12
6	Martin [®] Steel Inspection Door, P/N CYA-XXXXXXXXXXXX	14
7	Martin [®] Steel Inspection Door, P/N CYA-XXXXXXXXXXXX	16
8	Martin [®] Extended-Height Steel Inspection Door, P/N CYAE-XXXX-XXXXXX	19
9	Martin [®] Extended-Height Steel Inspection Door, P/N CYAE-XXXX-XXXXXX	21
10	Martin [®] Round Steel Inspection Door Assembly, P/N CYARD-XXXX	24
11	Martin [®] HD Steel Inspection Door, P/N CYAHD-XXXXXXXX	26
12	Martin [®] Round Urethane Inspection Door Assembly, P/N 30350-018X-MW	28

List of Tables

Table	Title	Page
I	Martin [®] Inspection Door Specifications.....	1
II	Martin [®] Rubber Inspection Door Part Numbers and Quantities	13
III	Martin [®] Steel Inspection Door Part Numbers and Quantities	15
IV	Martin [®] Steel Inspection Door Part Numbers and Quantities	18
V	Martin [®] Extended-Height Steel Inspection Door Part Numbers and Quantities	20
VI	Martin [®] Extended-Height Steel Inspection Door Part Numbers and Quantities	23
VII	Martin [®] Round Steel Inspection Door Assembly Part Numbers and Quantities	25
VIII	Martin [®] HD Steel Inspection Door Part Numbers and Quantities.....	27

Introduction

General

Martin[®] Inspection Doors are used to access mechanical equipment for service or to clean out material buildup. They can also be used as electrical switchboard covers, splash covers, and visual inspection doors. Martin[®] Inspection Doors were not designed to be mounted horizontally in areas where they may be stepped on.

Appendix A shows Martin[®] Inspection Door labels and Appendix B shows Martin[®] Inspection Door dimensions.

Martin[®] Inspection Door materials

Martin[®] Inspection Doors are made of a variety of materials to meet most needs. The nitrile and silicone doors are oil resistant and can be used in higher-temperature applications (see Table I). The silicone door is approved by the Food and Drug Administration (FDA) for use in the food industry (see Table I).

If you have questions about a particular Martin[®] Inspection Door's compatibility with certain chemicals, consult the *Elastomer Chemical Compatibility Chart for Martin[®] Conveyor Products*, available from Martin Engineering or representative. Table I shows the specifications for Martin[®] Inspection Doors.

Table I. Martin[®] Inspection Door Specifications

Type of Martin [®] Inspection Door	Max. Operating Temperature	Max. Pressure psi (bar)	Max. Vacuum psi (bar)
Rubber	155°F (68°C)	.29 (.020)	.36 (.025)
Nitrile	250°F (121°C)	.29 (.020)	.36 (.025)
Silicone	400°F (204°C)	.29 (.020)	.36 (.025)
Steel	350°F (177°C)	—	—

References

The following documents are referenced in this manual:

- American National Standards Institute (ANSI) z244.1-1982, *American National Standard for Personnel Protection - Lockout/Tagout of Energy Sources - Minimum Safety Requirements*, American National Standards Institute, Inc., 1430 Broadway, New York, NY 10018.
- Federal Register, Volume 54, Number 169, Part IV, 29 CFR Part 1910, *Control of Hazardous Energy Source (Lockout/Tagout); Final Rule*, Department of Labor, Occupational Safety and Health Administration (OSHA), 32nd Floor, Room 3244, 230 South Dearborn Street, Chicago, IL 60604.
- *Elastomer Chemical Compatibility Chart for Martin[®] Conveyor Products*, Martin Engineering.

Safety

All safety rules defined in the above documents and all owner/employer safety rules must be strictly followed when installing and servicing this equipment.

Materials required

Only standard hand tools are required to install and service this equipment.

Before Installing Martin[®] Inspection Door

IMPORTANT

The delivery service is responsible for damage occurring in transit. Martin Engineering CANNOT enter claims for damages. Contact your transportation agent for more information.

1. Inspect shipping container for damage. Report damage to delivery service immediately and fill out delivery service's claim form. Keep any damaged goods subject to examination.
2. Remove Martin[®] Inspection Door from shipping container. Equipment in container should include the following:
 - Martin[®] Inspection Door.
 - Martin[®] Inspection Door Warning Label, P/N 30382.
3. If anything is missing, contact Martin Engineering or representative.



WARNING

Before installing or servicing equipment, turn off and lock out/tag out energy source to conveyor and conveyor accessories.

4. Turn off and lock out/tag out energy source according to ANSI standards (see "References").

WARNING

If equipment will be installed in an enclosed area, test gas level or dust content before using a cutting torch or welding. Using a cutting torch or welding in an area with gas or dust may cause an explosion.

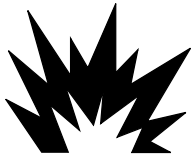

5. If using a cutting torch or welding, test atmosphere for gas level or dust content. Cover conveyor belt with fire retardant cover.

Installing Martin[®] Inspection Door

IMPORTANT

Read entire section before beginning work.

WARNING

Do not mount Martin[®] Inspection Door as follows: facing downward, in direct path of material, where door can be used as a step, or where material can collect in cover.

1. Determine location of Martin[®] Inspection Door on wall.
2. Follow the procedure under “Martin[®] Rubber Inspection Door,” “Martin[®] Steel Inspection Door,” “Martin[®] Inspection Door With Barrier Guard” or “Martin[®] Round Urethane Inspection Door.”

IMPORTANT

Martin[®] Rubber Inspection Doors should only be used when belt cleaner mainframe is required to extend through the door.

Martin[®] Rubber Inspection Door

1. Remove rubber door (A, Figure 1) from door frame (B).
2. Using door frame as template, mark location of mounting holes and inside dimension of door (access opening) on wall.

NOTE

Martin Engineering recommends bolting rather than welding Martin[®] Inspection Door frame to wall.

3. Using saw or cutting torch, cut hole for access opening 1/8 in. (3 mm) larger than access opening marked on wall. If you are bolting door frame to wall, drill holes for mounting screws. Remove burrs and sharp edges.

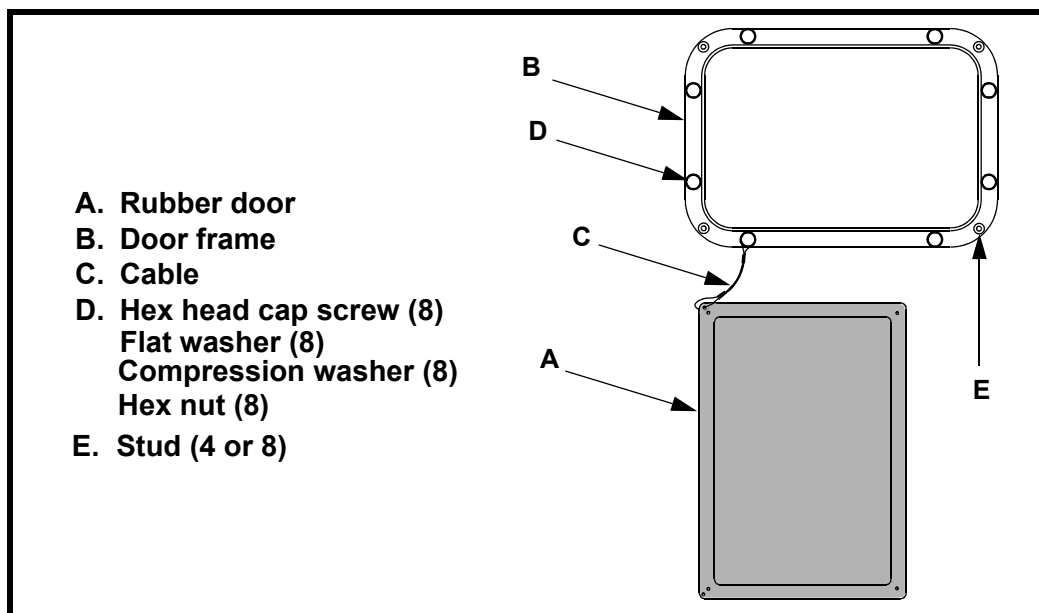

Figure 1. Installing Martin[®] Inspection Door

4. Grind wall surface smooth where door frame will contact it.
5. Bolt or weld Martin[®] Inspection Door frame (B) and cable (C) to wall as follows.
 - a. If bolting, do the following:
 - (1) Place cable eyelet on one of eight hex head cap screws (D).
 - (2) Install eight hex head cap screws, flat washers, compression washers, and hex nuts in drilled mounting holes. Install screw holding cable in a corner hole.
 - (3) Caulk around door frame to seal it to wall.
 - b. If welding, do the following:
 - (1) Tack weld door frame to wall, then skip weld 1/2 in. (12.7 mm) every 2 in. (51 mm).
 - (2) Tack weld cable to wall or door frame.
 - (3) Caulk around door frame to seal it to wall.
6. Push holes in rubber door (A) over studs (E) on door frame (B) until door opening is sealed.

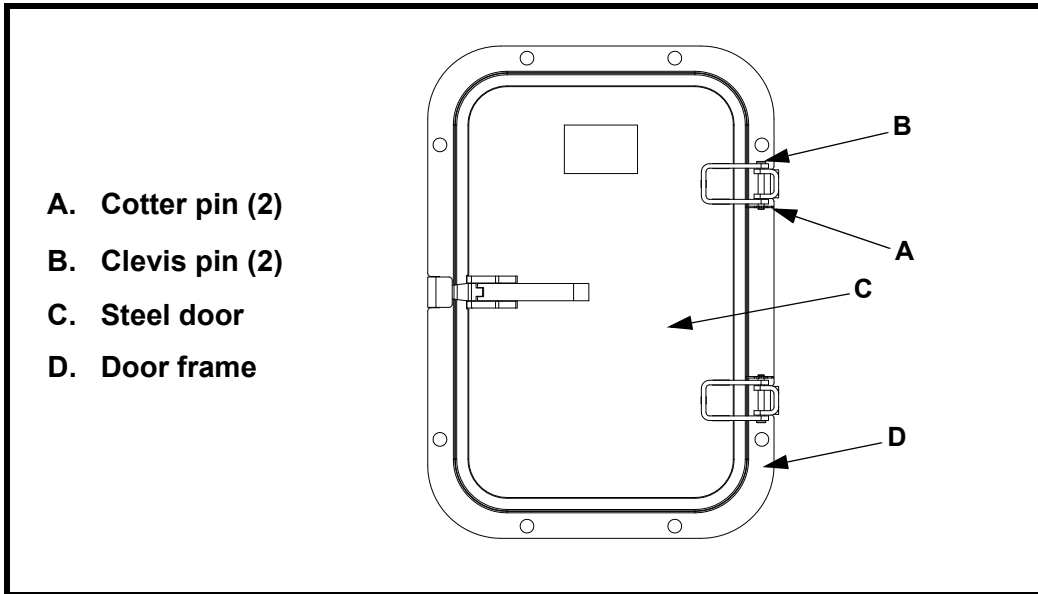

Figure 2. Installing Martin[®] Steel Inspection Door

NOTE

***Martin[®] Steel
Inspection Door***

Martin Engineering recommends installing Martin[®] Steel Inspection Door with hinges to the side or bottom.

1. Remove two cotter pins (A) and two clevis pins (B) from door hinges. Remove steel door (C) from frame (D).
2. Using door frame as template, mark location of mounting holes and inside dimension of door (access opening) on wall.

NOTE

Martin Engineering recommends bolting rather than welding Martin[®] Inspection Door frame to wall.

3. Using saw or cutting torch, cut hole for access opening 1/8 in. (3 mm) larger than access opening marked on wall. If you are bolting door frame to wall, drill holes for mounting screws. Remove burrs and sharp edges.
4. Grind wall surface smooth where door frame will contact it.
5. Bolt or weld Martin[®] Inspection Door frame to wall as follows.
 - a. If bolting, do the following:
 - (1) Install eight hex head cap screws, flat washers, compression washers, and hex nuts in mounting holes.
 - (2) Caulk around door frame to seal it to wall.
 - b. If welding, do the following:
 - (1) Tack weld door frame to wall, then skip weld 1/2 in. (12.7 mm) every 2 in. (51 mm).
 - (2) Caulk around door frame to seal it to wall.

IMPORTANT

Insert clevis pins so that holes for cotter pins are on the bottom.

6. Line up holes in door with hinges on frame and replace clevis pins and cotter pins.

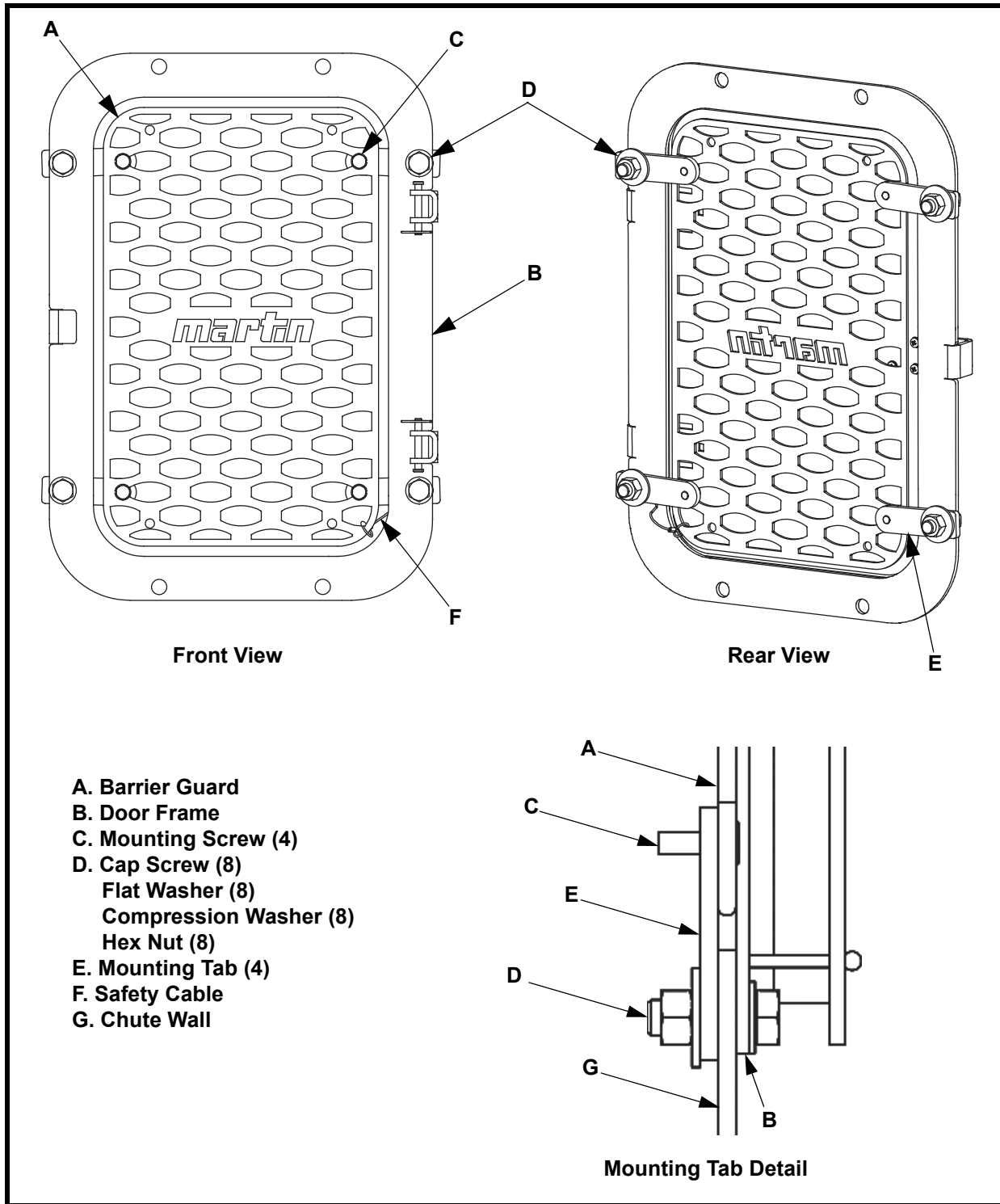

Figure 3. Installing Martin® Inspection Door With Barrier Guard

**Martin[®]
Inspection Door
with Barrier
Guard**

▲ WARNING

Barrier guard is designed to limit access where possible hazards exist. Do not use guard to absorb impact or retain material inside wall.

NOTE

Martin Engineering recommends bolting rather than welding Martin[®] Inspection Door with barrier guard to wall. Guard is secured to wall with tabs that are located on door frame mounting holes. Welding the door frame makes it difficult to properly locate tabs on wall.

1. Remove door from door frame.
2. Remove mounting screws (C), and guard (A) from door frame (B).
3. Follow steps 2 through 4 under either “Martin[®] Rubber Inspection Door” or “Martin[®] Steel Inspection Door.”
4. Install hex head cap screws with flat washers (D) through holes in door frame (B) and chute wall (G).
5. Place mounting tabs (E) over cap screws on inside of chute wall.
6. Install compression washers and hex nuts on cap screws and hand tighten.
7. Install four mounting screws (C) through guard (A) into mounting tabs (E).
8. Place safety cable eyelet (F) on one of the cap screws.
9. Tighten cap screws and nuts (D).
10. Follow steps 5 and 6 under either “Martin[®] Rubber Inspection Door” or “Martin[®] Steel Inspection Door” to complete installation.

**Martin[®]
Round Urethane
Inspection Door**

1. Remove urethane door (A, Figure 4) from Martin[®] Round Urethane Inspection Door frame (B).
2. Hold door frame against wall (C). Draw circle on wall around outside of door frame to mark location of door.
3. Using saw or cutting torch, cut hole for door frame. Remove burrs and sharp edges.
4. Grind wall surface smooth where door frame will contact it.
5. Insert door frame into hole until it is flush with inside of wall and extends outside of wall.
6. Fillet weld door frame to wall. Make continuous 1/4-in. (6-mm) weld around entire door frame.
7. Tack weld end of cable (D) to wall or door frame.
8. Push urethane door over door frame until door opening is sealed.

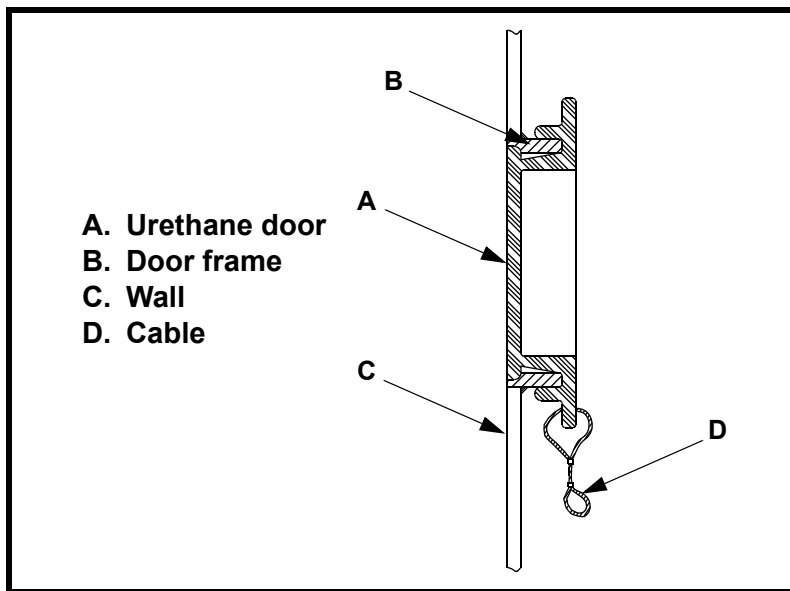

Figure 4. Installing Martin[®] Round Urethane Inspection Door

After Installing Martin[®] Inspection Door

1. Thoroughly wipe wall clean above Martin[®] Inspection Door. Place Martin[®] Inspection Door Warning Label, P/N 30382 on wall visible to anyone using Martin[®] Inspection Door.
2. Observe Martin[®] Inspection Door during normal operations. If material is escaping through door, make sure rubber door is securely seated against door frame or steel door is firmly seated against rubber silicone seal. Check caulk around door frame for leaks.

Weekly Maintenance

1. Make sure all fasteners are tight. Tighten if necessary.
2. Wipe all warning labels clean. If labels are damaged or are not readable, contact Martin Engineering or representative for replacements.
3. Check rubber door for tears, holes, or cracks. Replace as necessary.
4. Check silicone sponge seal around steel door for tears or cracks. Replace as necessary.

Part Numbers

Martin® Inspection Door Assemblies

This section provides product names and corresponding part numbers for Martin® Inspection Doors and related equipment. Please reference part numbers when ordering parts:

With rubber door: See Figure 5.

- 9 x 12 in. (229 x 305 mm): P/N CYAR-0912XXXX
- 12 x 14 in. (305 x 356 mm): P/N CYAR-1214XXXX
- 12 x 18 in. (305 x 457 mm): P/N CYAR-1218XXXX
- 18 x 24 in. (457 x 610 mm): P/N CYAR-1824XXXX
- 24 x 24 in. (610 x 610 mm): P/N CYAR-2424XXXX

With steel door: See Figures 6, 7 and 10.

- 4 in. (114 mm) Diameter: P/N CYARD-4XXX
- 6 in. (152 mm) Diameter: P/N CYARD-6XXX
- 8 in. (203 mm) Diameter: P/N CYARD-8XXX
- 9 x 12 in. (229 x 305 mm): P/N CYA-0912XXXXXX
- 12 x 12 in. (305 x 305 mm): P/N CYA-1212XXXXXX
- 12 x 14 in. (305 x 356 mm): P/N CYA-1214XXXXXX
- 12 x 18 in. (305 x 457 mm): P/N CYA-1218XXXXXX
- 16 x 16 in. (406 x 406 mm): P/N CYA-1616XXXXXX
- 18 x 12 in. (457 x 305 mm): P/N CYA-1812XXXXXX
- 18 x 14 in. (457 x 356 mm): P/N CYA-1814XXXXXX
- 18 x 18 in. (457 x 457 mm): P/N CYA-1818XXXXXX
- 18 x 24 in. (457 x 610 mm): P/N CYA-1824XXXXXX
- 20 x 20 in. (508 x 508 mm): P/N CYA-2020XXXXXX
- 20 x 30 in. (508 x 762 mm): P/N CYA-2030XXXXXX
- 24 x 18 in. (610 x 457 mm): P/N CYA-2418XXXXXX
- 24 x 24 in. (610 x 610 mm): P/N CYA-2424XXXXXX
- 24 x 30 in. (610 x 762 mm): P/N CYA-2430XXXXXX
- 30 x 18 in. (762 x 457 mm): P/N CYA-3018XXXXXX
- 30 x 30 in. (762 x 762 mm): P/N CYA-3030XXXXXX
- 36 x 24 in. (914 x 610 mm): P/N CYA-3624XXXXXX
- 36 x 36 in. (914 x 914 mm): P/N CYA-3636XXXXXX

With extended-height steel door: See Figures 8 and 9.

- 9 x 12 in. (229 x 305 mm): P/N CYAE-0912-XXXXXX
- 12 x 14 in. (305 x 356 mm): P/N CYAE-1214-XXXXXX
- 12 x 18 in. (305 x 457 mm): P/N CYAE-1218-XXXXXX
- 18 x 24 in. (457 x 610 mm): P/N CYAE-1824-XXXXXX
- 24 x 24 in. (610 x 610 mm): P/N CYAE-2424-XXXXXX

With HD steel door: See Figure 11.

- 9 x 12 in. (229 x 305 mm): P/N CYAHD-0912XXXXXX
- 12 x 14 in. (305 x 356 mm): P/N CYAHD-1214XXXXXX
- 12 x 18 in. (305 x 457 mm): P/N CYAHD-1218XXXXXX
- 18 x 24 in. (457 x 610 mm): P/N CYAHD-1824XXXXXX
- 24 x 24 in. (610 x 610 mm): P/N CYAHD-2424XXXXXX

***Martin[®] Barrier
Guard Kit***

For use with Martin[®] Rubber Inspection Doors:

- 9 x 12 in. (229 x 305 mm): P/N 38414-0912
- 12 x 14 in. (305 x 356 mm): P/N 38414-1214
- 12 x 18 in. (305 x 457 mm): P/N 38414-1218
- 18 x 24 in. (457 x 610 mm): P/N 38414-1824
- 24 x 24 in. (610 x 610 mm): P/N 38414-2424

For use with Martin[®] Steel Inspection Doors:

- 9 x 12 in. (229 x 305 mm): P/N 38409-0912
- 12 x 12 in. (305 x 305 mm): P/N 38409-1212
- 12 x 14 in. (305 x 356 mm): P/N 38409-1214
- 12 x 18 in. (305 x 457 mm): P/N 38409-1218
- 16 x 16 in. (406 x 406 mm): P/N 38409-1616
- 18 x 12 in. (457 x 305 mm): P/N 38409-1812
- 18 x 14 in. (457 x 356 mm): P/N 38409-1814
- 18 x 18 in. (457 x 457 mm): P/N 38409-1818
- 18 x 24 in. (457 x 610 mm): P/N 38409-1824
- 20 x 20 in. (508 x 508 mm): P/N 38409-2020
- 20 x 30 in. (508 x 762 mm): P/N 38409-2030
- 24 x 18 in. (610 x 457 mm): P/N 38409-2418
- 24 x 24 in. (610 x 610 mm): P/N 38409-2424
- 24 x 30 in. (610 x 762 mm): P/N 38409-2430
- 30 x 18 in. (762 x 457 mm): P/N 38409-3018
- 30 x 30 in. (762 x 762 mm): P/N 38409-3030
- 36 x 24 in. (914 x 610 mm): P/N 38409-3624
- 36 x 36 in. (914 x 914 mm): P/N 38409-3636

***Martin[®]
Round Urethane
Inspection Door
Assemblies***

See Figure 12.

Standard 8-in. (203-mm) Door: P/N 30348-018X-MW

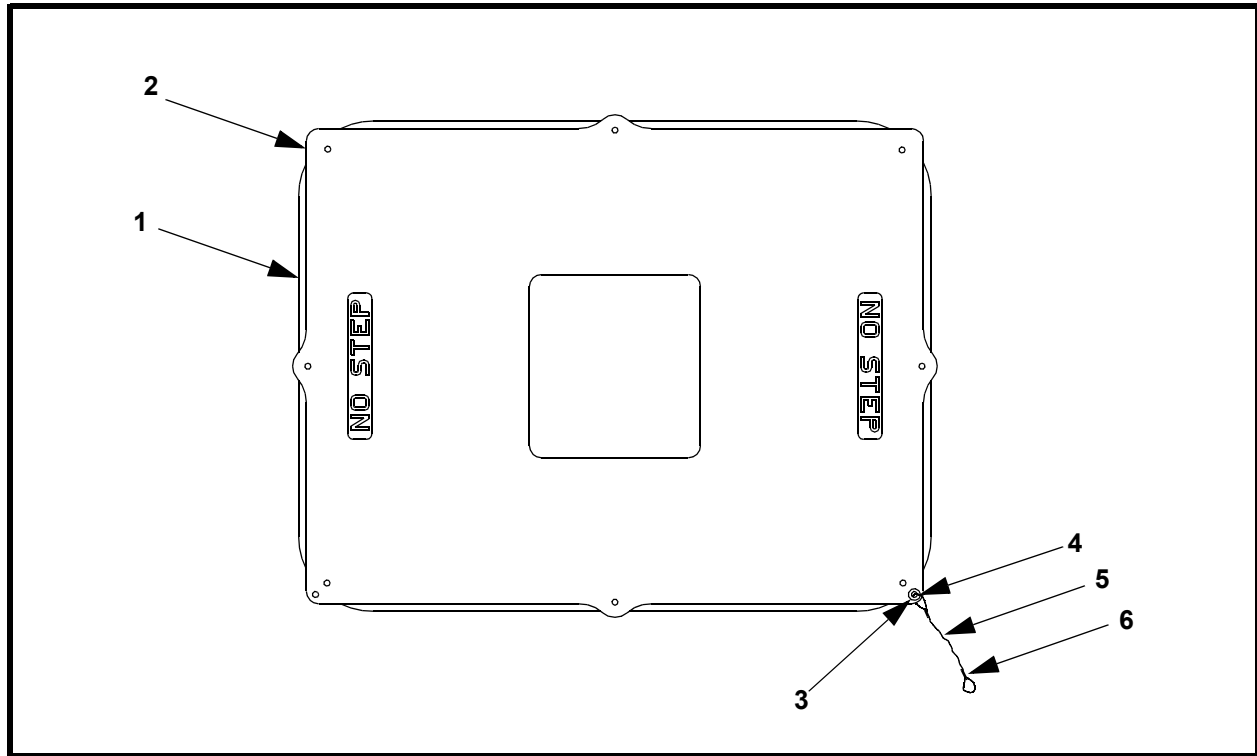

Item	Description	Part No.	Qty.
1	Door Frame	Table II	1
2	Rubber Door	Table II	1
3	Grommet Eyelet	32407-01	1
4	Grommet Washer	32407-02	1
5	Ø .0625 Galvanized Cable	Table II	1.25 ft
6	Cable Clip	Table II	2
7 (NS)	Warning Label	30382	1
8 (NS)	Operator's Manual	M3891	1
9 (NS)	Kit Mounting Hardware	Table II	1
10 (NS)	Barrier Guard Kit	Table II	1

Figure 5. Martin[®] Rubber Inspection Door Assemblies, P/N CYAR-XXXXXXXX*

*The first four Xs indicate the approximate door size in inches: -0912, -1214, -1218, -1824, or -2424. The next X indicates the door frame material: 304 stainless steel (C), 316 stainless steel (S), painted mild steel (Blank); The next X indicates rubber door temperature range: with high-temperature door (H), with mid-temperature door (N), with standard rubber door (Blank); The next X indicates if mounting hardware is included: with mounting hardware (M), without mounting hardware (Blank); The next X indicates if a barrier guard is included: with barrier guard (G), without barrier guard (Blank).

Table II. Martin® Rubber Inspection Door Part Numbers and Quantities

Part No.	P/N Item 2
CYAR-XXXX	27708-XXXX
CYAR-XXXXXH	28557-XXXX
CYAR-XXXXXN	28246-XXXX

Part No.	P/N Item 5	P/N Item 6
CYAR-XXXX	102249	28112
CYAR-XXXXC	100598	33832
CYAR-XXXXS	100598	33832

Part No.	P/N Item 9
CYAR-XXXXM	38228
CYAR-XXXXCM	38228-SS
CYAR-XXXXSM	38228-316SS

Part No.	P/N Item 1	P/N Item 10
CYAR-0912XXXX	38412-0912W	38409-0912
CYAR-1214XXXX	38412-1214W	38409-1214
CYAR-1218XXXX	38412-1218W	38409-1218
CYAR-1824XXXX	38412-1824W	38409-1824
CYAR-2424XXXX	38412-2424W	38409-2424
CYAR-0912CXXX	38412-0912WC	38409-0912C
CYAR-1214CXXX	38412-1214WC	38409-1214C
CYAR-1218CXXX	38412-1218WC	38409-1218C
CYAR-1824CXXX	38412-1824WC	38409-1824C
CYAR-2424CXXX	38412-2424WC	38409-2424C
CYAR-0912SXXX	38412-0912WS	38409-0912S
CYAR-1214SXXX	38412-1214WS	38409-1214S
CYAR-1218SXXX	38412-1218WS	38409-1218S
CYAR-1824SXXX	38412-1824WS	38409-1824S
CYAR-2424SXXX	38412-2424WS	38409-2424S

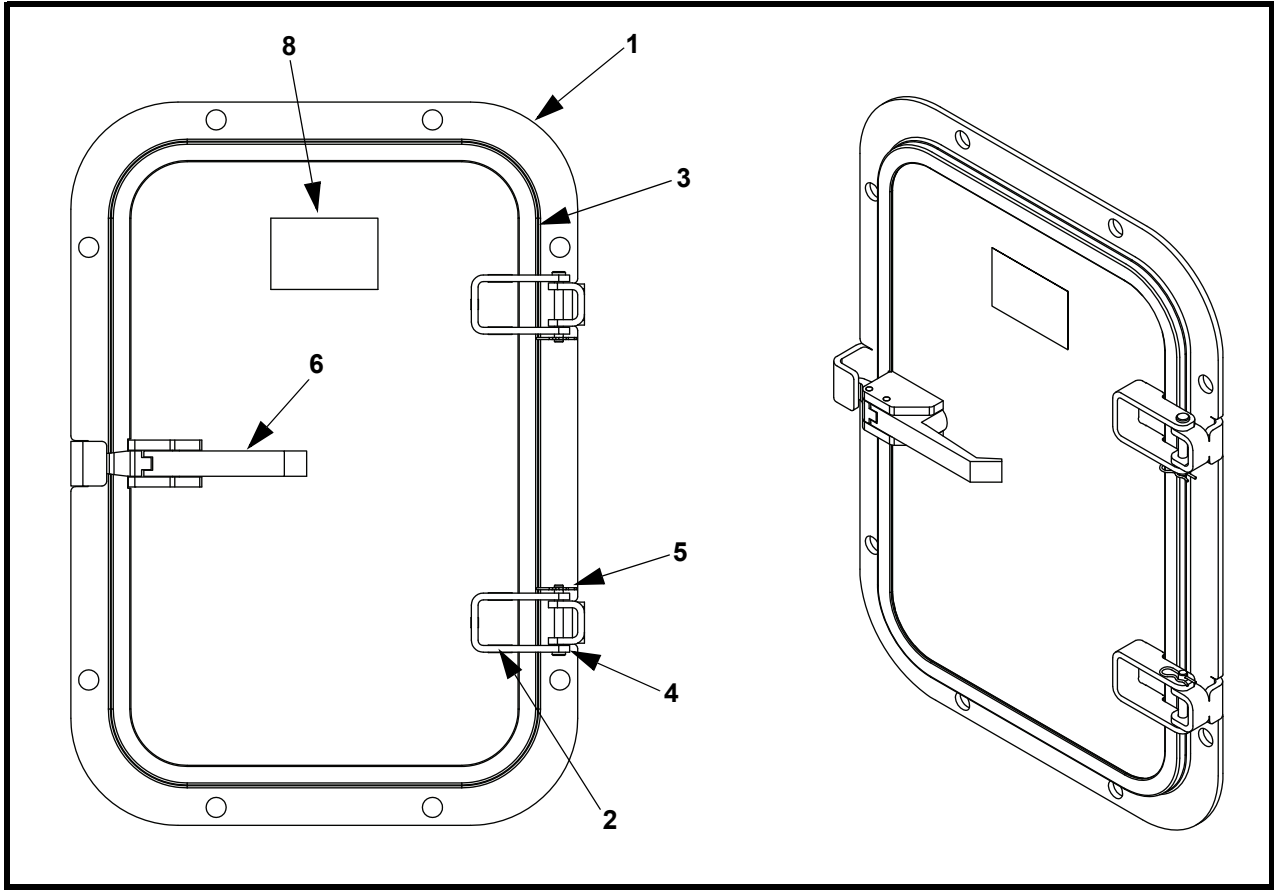

Item	Description	Part No.	Qty.
1	Door Frame	38931-XXXXX**	1
2	Steel Door Weldment	38932-XXXXX**	1
3	Gasket Rubber Door Seal	38400-XXXX	1
4	Pin, Clevis 1/4 x 1-7/8 SS	38641	2
5	Hairpin Cotter .06 DIA x 1.13 SS	34951	2
6	Over Center Lever Latch	Table III	1
7 (NS)	Screw PHPM #10-32NF x 1/2 with washer	Table III	4
8	Label Martin Product	38048	1
9 (NS)	Label Door Warning	30382	1
10 (NS)	Operator's Manual	M3891	1
11 (NS)	Kit Mounting Hardware	Table III	1
12 (NS)	Barrier Guard Kit	38409-XXXXX**	1

Figure 6. Martin® Steel Inspection Door, P/N CYA-XXXXXXXXX*

*The first four Xs indicate the approximate door size in inches (width x height); The next X indicates the door material: 304 stainless steel (C), 316 stainless steel (S), painted mild steel (Blank); The next X indicates if mounting hardware is included: with mounting hardware (M), without mounting hardware (Blank); The next X indicates if a barrier guard is included: with barrier guard (G), without barrier guard (Blank).

**The first four Xs indicate the approximate door size in inches (width x height); The next X indicates material: 304 stainless steel (C), 316 stainless steel (S), painted mild steel (Blank).

Table III. Martin® Steel Inspection Door Part Numbers and Quantities

Part No.	P/N Item 6
CYA-XXXX	37051
CYA-XXXXL	37051-L

Part No.	P/N Item 7
CYA-XXXX	38182
CYA-XXXXC	38182-SS
CYA-XXXXS	38182-SS

Part No.	P/N Item 11
CYA-XXXXM	38228
CYA-XXXXCM	38228-SS
CYA-XXXXSM	38228-316SS

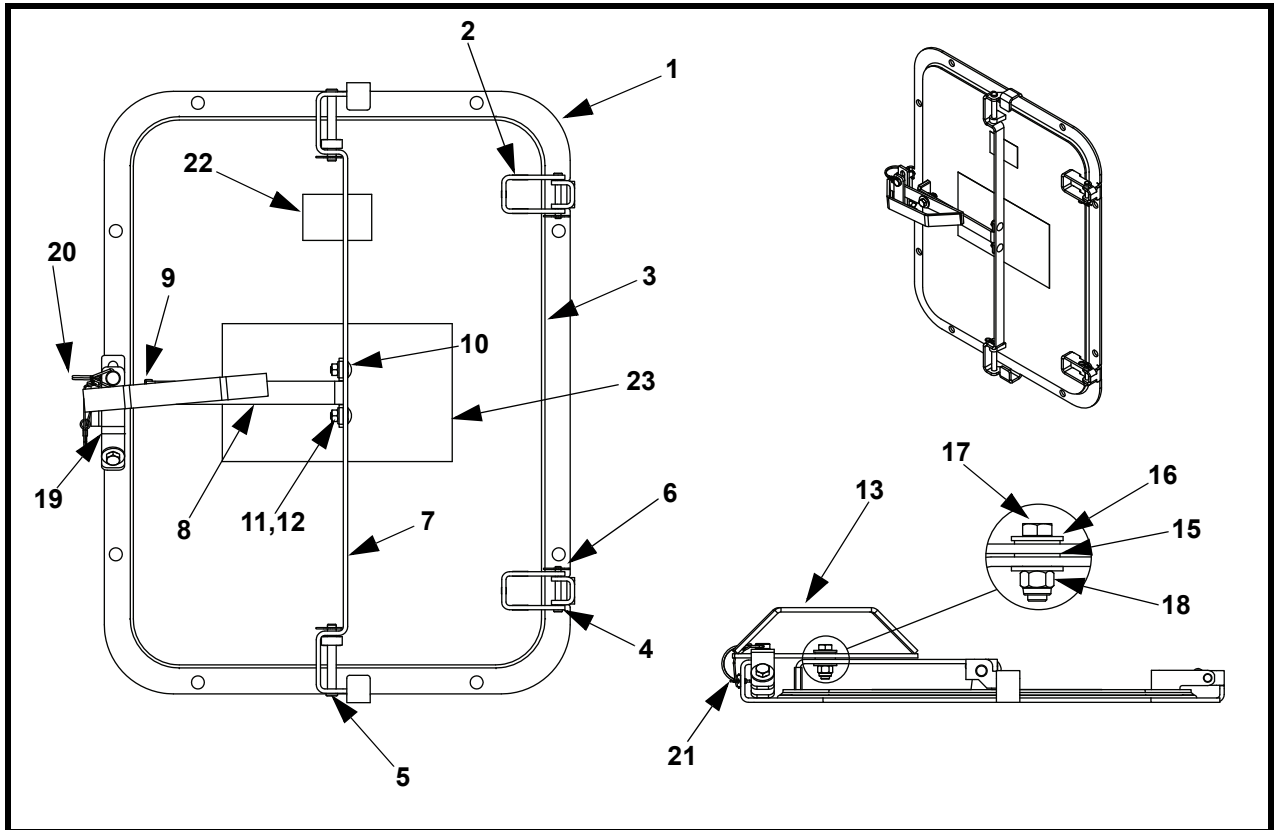

Figure 7. Martin[®] Steel Inspection Door, P/N CYA-XXXXXXXXXX*

*The first four Xs indicate the approximate door size in inches (width x height); The next X indicates the door material: 304 stainless steel (C), 316 stainless steel (S), painted mild steel (Blank); The next X indicates if mounting hardware is included: with mounting hardware (M), without mounting hardware (Blank); The next X indicates if a barrier guard is included: with barrier guard (G), without barrier guard (Blank).

Item	Description	Part No.	Qty.
1	Door Frame	38931H-XXXXX*	1
2	Steel Door Weldment	38932H-XXXXX*	1
3	Gasket Rubber Door Seal	38400-XXXX	1
4	Pin, Clevis 1/4 x 1-7/8 SS	38641	2
5	Pin, Clevis 3/8 x 3 SS	Table IV	2
6	Hairpin Cotter .06 Dia. x 1.13 SS	Table IV	4
7	Hinge Cam	38935-XX**	1
8	Handle Arm	Table IV	1
9	Vinyl Cap	38940	1
10	Bolt RN HD SQ NK 5/16-18 x .75 ZP	Table IV	2
11	Washer Compression 5/16	Table IV	2
12	Nut Hex 5/16-18NC ZP	Table IV	2
13	Handle	Table IV	1
14 (NS)	Handle Spacer	Table IV	1
15	Washer Nylon 9/16	38710	2
16	Washer Flat 3/8 Wide ZP	Table IV	4
17	Screw HHC 3/8-16NC x 1-1/4 ZP	Table IV	2
18	Nut Hex Elastic Lock 3/8-16NC ZP	Table IV	2
19	Latch Bar	Table IV	1
20	Lock Pin with Lanyard and Mount	38877	1
21	Rivet 3/16 Dia. x 1/4	37905	1
22 (NS)	Label Martin Product	38048	1
23 (NS)	Label Martin Product	22193-02	1
24 (NS)	Label Door Warning	30382	1
25 (NS)	Operator's Manual	M3891	1
26 (NS)	Kit Mounting Hardware	Table IV	1
27 (NS)	Barrier Guard Kit	38409-XXXXX*	1

Figure 7. Martin[®] Steel Inspection Door, P/N CYA-XXXXXXXXXX

*The first four Xs indicate the approximate door size in inches (width x height); The next X indicates material: 304 stainless steel (C), 316 stainless steel (S), painted mild steel (Blank).

**XX indicates the height of the door in inches.

Table IV. Martin® Steel Inspection Door Part Numbers

Part No.	P/N Item 5	P/N Item 6	P/N Item 8	P/N Item 10	P/N Item 11	P/N Item 12	P/N Item 13
CYA-XXXX	38941	34951	38936	38942	11452	11963	38937
CYA-XXXXC	38941	34951	38936-C	38942-C	38698	37723	38937-C
CYA-XXXXS	38941-S	38934	38936-S	38942-S	38698	37723	38937-S

Part No.	P/N Item 14	P/N Item 16	P/N Item 17	P/N Item 18	P/N Item 19	P/N Item 26
CYA-XXXX	38681	18007	12215	14201	38571	38228
CYA-XXXXC	38681-SS	16055	32483	16204	38571-C	38228-SS
CYA-XXXXS	38681-SS	16055	32483	16204	38571-S	38228-316SS

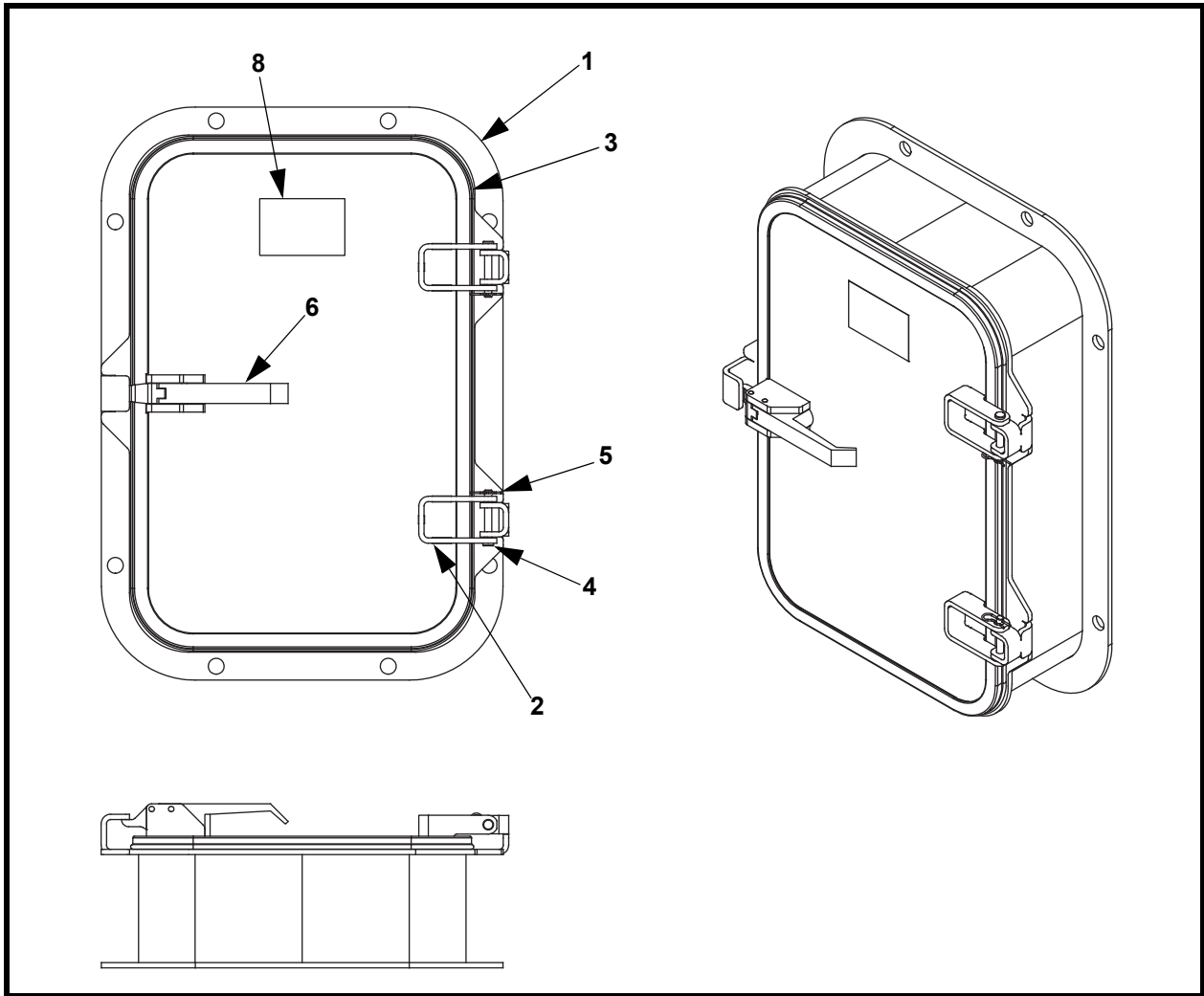

Figure 8. Martin® Extended-Height Steel Inspection Door, P/N CYAE-XXXX-XXXXXX*

*The first four Xs indicate the approximate door size in inches:-0912, -1214, or -1218. The next XX indicates the frame band height in inches: -03, -04, -05, -06, -07, or -08. The next X indicates the door material: 304 stainless steel (C), 316 stainless steel (S), painted mild steel (Blank); The next X indicates if mounting hardware is included: with mounting hardware (M), without mounting hardware (Blank); The next X indicates if the latch is lockable: with lockable latch (L), with standard nonlockable latch (Blank); The next X indicates if a barrier guard is included: with barrier guard (G), without barrier guard (Blank).

Item	Description	Part No.	Qty.
1	Door Frame Weldment	38945-XXXX-XXWX*	1
2	Steel Door Weldment	38932-XXXXX**	1
3	Rubber Door Gasket	Table V	1
4	Pin, Clevis Stainless Steel 1/4 x 1-7/8	38641	2
5	Hairpin Cotter 0.6 DIA x 1.13 SS	34951	2
6	Over Center Lever Latch	Table V	1
7	Screw PHPM #10-32NF x 1/2 w/washer	Table V	4
8	Label Martin Product	38048	1
9 (NS)	Label Door Warning	30382	1
10 (NS)	Operator's Manual	M3891	1
11 (NS)	Kit Mounting Hardware	Table V	1
12 (NS)	Barrier Guard Kit	38409-XXXXX**	1

*The first four Xs indicate the approximate door size in inches: -0912, -1214, or -1218. The next XX indicates the frame band height in inches: -03, -04, -05, -06, -07, or -08. The next X indicates the door material: 304 stainless steel (C), 316 stainless steel (S), painted mild steel (Blank).

**The first four Xs indicate the approximate door size in inches: -0912, -1214, or -1218. The next X indicates the door material: 304 stainless steel (C), 316 stainless steel (S), painted mild steel (Blank).

Table V. Martin® Extended-Height Steel Inspection Door Part Numbers and Quantities

Part No.	P/N Item 3
CYAE-0912-XXXXXX	38400-0912
CYAE-1214-XXXXXX	38400-1214
CYAE-1218-XXXXXX	38400-1218

Part No.	P/N Item 6
CYAE-XXXX-XXXX	37051
CYAE-XXXX-XXLX	37051-L

Part No.	P/N Item 7
CYAE-XXXX-XXXX	38182
CYAE-XXXX-XXCX	38182-SS
CYAE-XXXX-XXSX	38182-SS

Part No.	P/N Item 11
CYAE-XXXX-XXXX	38228
CYAE-XXXX-XXCMX	38228-SS
CYAE-XXXX-XXSMX	38228-316SS

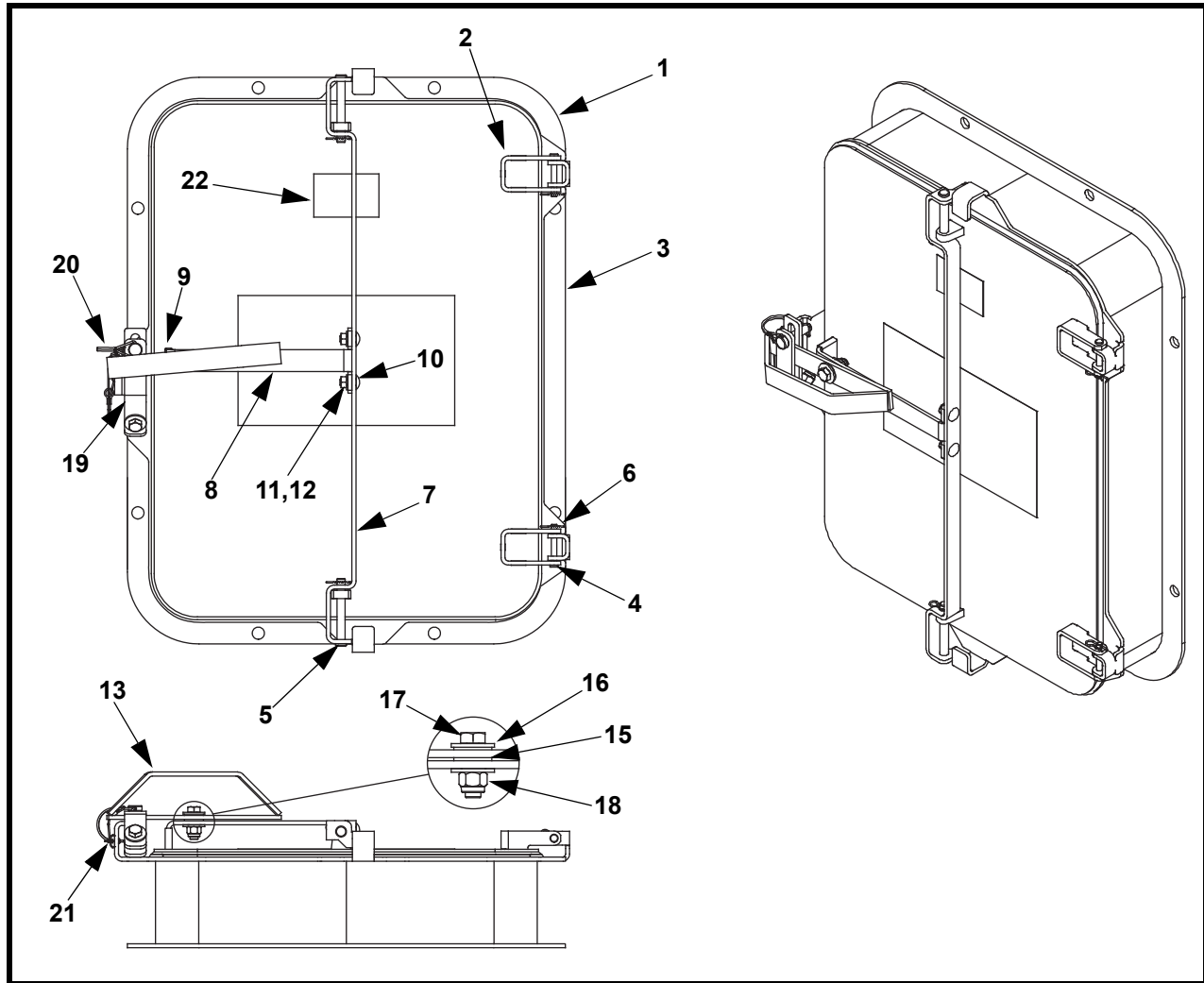

Figure 9. Martin® Extended-Height Steel Inspection Door, P/N CYAE-XXXX-XXXXXX*

*The first four Xs indicate the approximate door size in inches:-1824 or -2424. The next XX indicates the frame band height in inches: -03, -04, -05, -06, -07, -08, -09, -10, -11, or -12. The next X indicates the door material: 304 stainless steel (C), 316 stainless steel (S), painted mild steel (Blank); The next X indicates if mounting hardware is included: with mounting hardware (M), without mounting hardware (Blank); The next X indicates if a barrier guard is included: with barrier guard (G), without barrier guard (Blank).

Item	Description	Part No.	Qty.
1	Door Frame	38931H-XXXXX*	1
2	Steel Door Weldment	38932H-XXXXX*	1
3	Gasket Rubber Door Seal	38400-XXXX	1
4	Pin, Clevis 1/4 x 1-7/8 SS	38641	2
5	Pin, Clevis 3/8 x 3 SS	Table VI	2
6	Hairpin Cotter .06 Dia. x 1.13 SS	Table VI	4
7	Hinge Cam	38935-XX**	1
8	Handle Arm	Table VI	1
9	Vinyl Cap	38940	1
10	Bolt RN HD SQ NK 5/16-18 x .75 ZP	Table VI	2
11	Washer Compression 5/16	Table VI	2
12	Nut Hex 5/16-18NC ZP	Table VI	2
13	Handle	Table VI	1
14 (NS)	Handle Spacer	Table VI	1
15	Washer Nylon 9/16	38710	2
16	Washer Flat 3/8 Wide ZP	Table VI	4
17	Screw HHC 3/8-16NC x 1-1/4 ZP	Table VI	2
18	Nut Hex Elastic Lock 3/8-16NC ZP	Table VI	2
19	Latch Bar	Table VI	1
20	Lock Pin with Lanyard and Mount	38877	1
21	Rivet 3/16 Dia. x 1/4	37905	1
22 (NS)	Label Martin Product	38048	1
23 (NS)	Label Martin Product	22193-02	1
24 (NS)	Label Door Warning	30382	1
25 (NS)	Operator's Manual	M3891	1
26 (NS)	Kit Mounting Hardware	Table VI	1
27 (NS)	Barrier Guard Kit	38409-XXXXX*	1

Figure 9. Martin® Extended-Height Steel Inspection Door, P/N CYAE-XXXX-XXXXXX

*The first four Xs indicate the approximate door size in inches (width x height); The next X indicates material:
304 stainless steel (C), 316 stainless steel (S), painted mild steel (Blank).

**XX indicates the height of the door in inches.

Table VI. Martin® Extended-Height Steel Inspection Door Part Numbers

Part No.	P/N Item 5	P/N Item 6	P/N Item 8	P/N Item 10	P/N Item 11	P/N Item 12	P/N Item 13
CYA-XXXX	38941	34951	38936	38942	11452	11963	38937
CYA-XXXXC	38941	34951	38936-C	38942-C	38698	37723	38937-C
CYA-XXXXS	38941-S	38934	38936-S	38942-S	38698	37723	38937-S

Part Numbers

Part No.	P/N Item 14	P/N Item 16	P/N Item 17	P/N Item 18	P/N Item 19	P/N Item 26
CYA-XXXX	38681	18007	12215	14201	38571-P	38228
CYA-XXXXC	38681-SS	16055	32483	16204	38571-C	38228-SS
CYA-XXXXS	38681-SS	16055	32483	16204	38571-S	38228-316SS

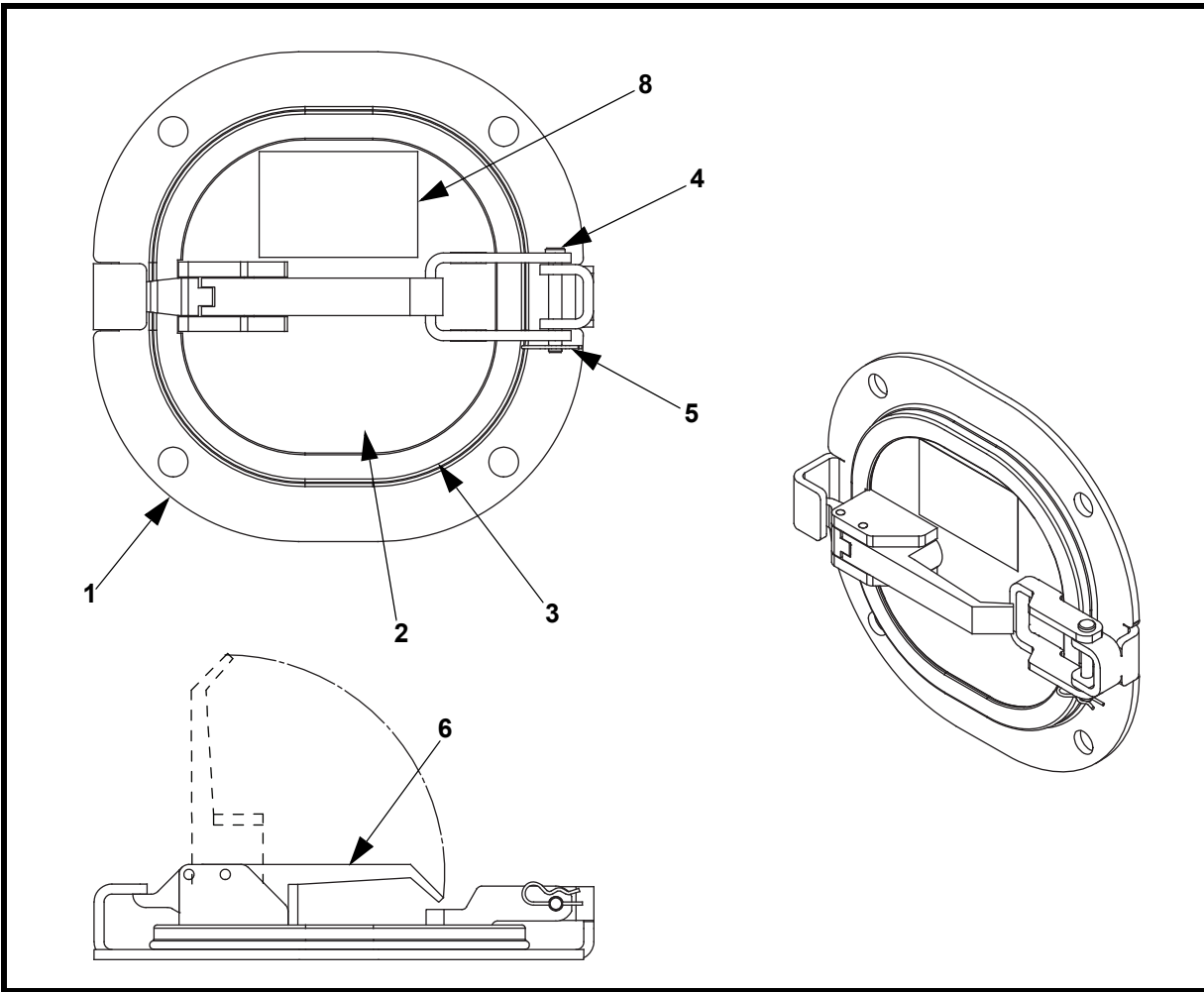

Item	Description	Part No.	Qty.
1	Door Frame	Table VII	1
2	Door Weldment	Table VII	1
3	Gasket Rubber Door Seal	Table VII	1
4	Pin Clevis 1/4 x 1-7/8 SS	38641	1
5	Hairpin Cotter .06 Dia. x 1.13 SS	34951	1
6	Over Center Lever Latch	Table VII	1
7 (NS)	Screw PHPM #10-32NF x 1/2 with Washer	Table VII	4
8	Label Martin Product	38048	1
9 (NS)	Label Door Warning	30382	1
10 (NS)	Operator's Manual	M3891	1
11 (NS)	Kit Mounting Hardware	Table VII	1
12 (NS)	Barrier Guard Kit	Table VII	1

Figure 10. Martin® Round Steel Inspection Door Assembly, P/N CYARD-XXXX*

*First X indicates door diameter in inches; The next X indicates door material: 304 stainless steel (C), 316 stainless steel (S), painted mild steel (Blank); The next X indicates if mounting hardware is included: with mounting hardware (M), without mounting hardware (Blank); The next X indicates if the latch is lockable: with lockable latch (L), with standard nonlockable latch (Blank).

**Table VII. Martin® Round Steel Inspection Door Assembly
Part Numbers and Quantities**

Part Number	Item 1 P/N	Item 2 P/N	Item 12 P/N
CYARD-4XXX	38931RD-4W	38932RD-4W	38409R-4
CYARD-6XXX	38931RD-6W	38932RD-6W	38409R-6
CYARD-8XXX	38931RD-8W	38932RD-8W	38409R-8
CYARD-4CXX	38931RD-4WC	38932RD-4WC	38409R-4C
CYARD-6CXX	38931RD-6WC	38932RD-6WC	38409R-6C
CYARD-8CXX	38931RD-8WC	38932RD-8WC	38409R-8C
CYARD-4SXX	38931RD-4WS	38932RD-4WS	38409R-4S
CYARD-6SXX	38931RD-6WS	38932RD-6WS	38409R-6S
CYARD-8SXX	38931RD-8WS	38932RD-8WS	38409R-8S

Part Number	Item 3 P/N
CYARD-4XXX	38400-4
CYARD-6XXX	38400-6
CYARD-8XXX	38400-8

Part Number	Item 6 P/N
CYARD-X	37051
CYARD-XL	37051-L

Part Number	Item 7 P/N
CYARD-X	38182
CYARD-XC	38182-SS
CYARD-XS	38182-SS

Part Number	Item 11 P/N
CYARD-XM	38228-04
CYARD-XCM	38228-04SS
CYARD-XSM	38228-04316SS

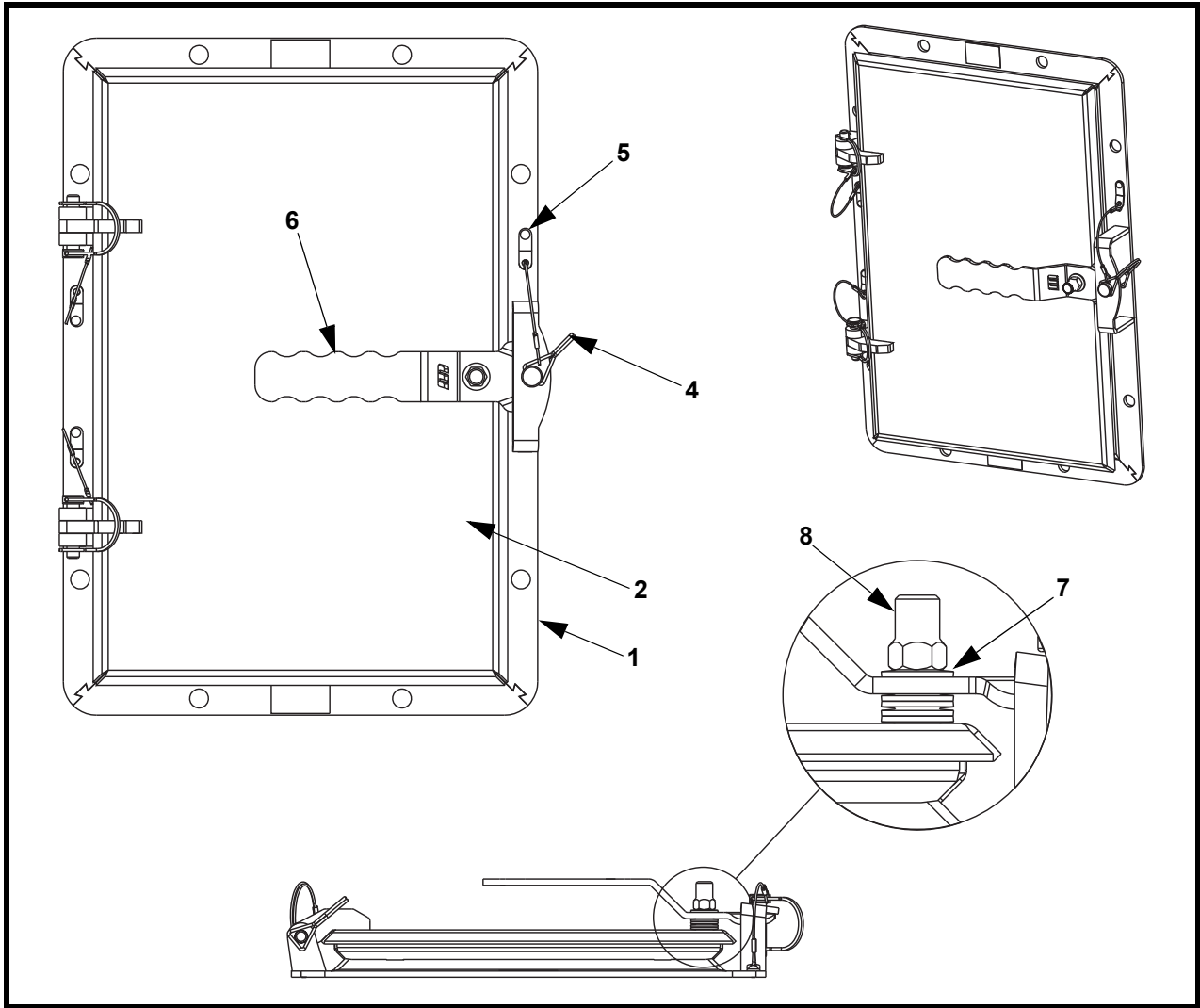

Figure 11. Martin® HD Steel Inspection Door, P/N CYAHD-XXXXXXXXX*

*The first four Xs indicate the approximate door size in inches (width x height); The next X indicates the door material: 304 stainless steel (C), 316 stainless steel (S), painted mild steel (Blank); The next X indicates the door liner material: AR400 (4), AR500 (5), no liner (Blank); The next X indicates if mounting hardware is included: with mounting hardware (M), without mounting hardware (Blank); The next X indicates if a barrier guard is included: with barrier guard (G), without barrier guard (Blank).

**The first four Xs indicate the approximate door size in inches (width x height); The next X indicates material: 304 stainless steel (C), 316 stainless steel (S), painted mild steel (Blank).

Item	Description	Part No.	Qty.
1	Frame Weldment	39160-XXXXX**	1
2	Door Weldment	Table VIII	1
3 (NS)	Seal	Table VIII	1
4	Snap Lock Pin with Lanyard 3/8 SS	38577	Table VIII
5	Screw Drive No. 7 x 3/16 LG ZP	32873	Table VIII
6	Latch Handle	39159-C	Table VIII
7	Washer Compression 3/8 SS	28565	Table VIII
8	Nut Hex Top Lock 3/8-16NC SS	39152-C	Table VIII
9 (NS)	Label Martin Product	32238-01	2
10 (NS)	Kit Mounting Hardware	Table VIII	1
11 (NS)	Logo Decal	22193-02	1
12 (NS)	Barrier Guard Kit	38409-XXXXX**	1
13 (NS)	Operator's Manual	M3891	1

Figure 11. Martin® HD Steel Inspection Door, P/N CYAHD-XXXXXXXXXX

**The first four Xs indicate the approximate door size in inches (width x height); The next X indicates material: 304 stainless steel (C), 316 stainless steel (S), painted mild steel (Blank).

Table VIII. Martin® HD Steel Inspection Door Part Numbers and Quantities

Part No.	P/N Item 2	P/N Item 3	Qty Items 4,5	Qty Items 6,8	Qty Item 7
CYAHD-0912XXXX	39162-0912X*	39164-0912	3	1	5
CYAHD-1214XXXX	39162-1214X*	39164-1214	3	1	5
CYAHD-1218XXXX	39162-1218X*	39164-1218	3	1	5
CYAHD-1818XXXX	39162-1818X*	39164-1818	3	1	5
CYAHD-1824XXXX	39162-1824X*	39164-1824	4	2	10
CYAHD-2424XXXX	39162-2424X*	39164-2424	4	2	10

*X indicates liner material: AR400 (4), AR500 (5), no liner (Blank).

Part No.	P/N Item 10
CYAHD-XXXXM	38228
CYAHD-XXXXCM	38228-SS
CYAHD-XXXXSM	38228-316SS

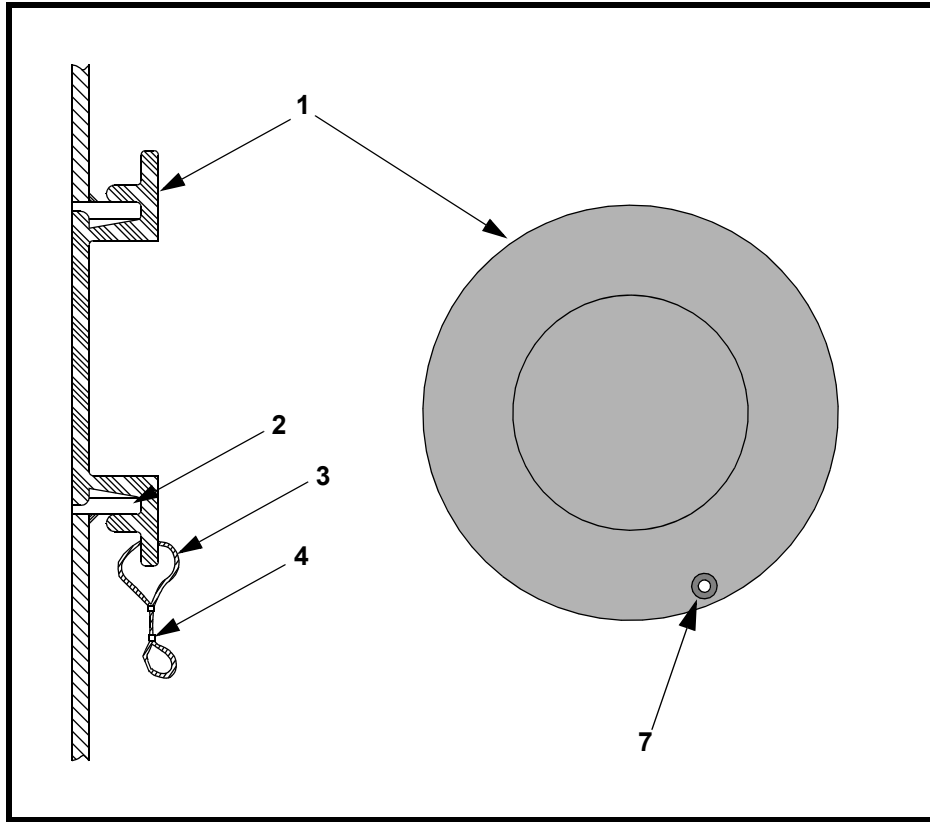

Item	Description	Part No.	Qty.
1	Plug Door	30348-081	1
2	Plug Door Frame	30349-018X-MW	1
3	Ø .0625 Galvanized Cable	102249	1.25ft
4	Cable Clip	28112	2
5 (NS)	Warning Label	30382	1
6 (NS)	Operator's Manual	M3891	1
7	Grommet and Washer	32407	1
8 (NS)	Handle	37974	1
9 (NS)	Screw RHM 1/4-20NC-2A x 3/4	17325	2
10 (NS)	Washer Compression 1/4 ZP	11521	2
11 (NS)	Nut Crown Elastic Lock 1/4-20 ZP	30227	2
12 (NS)	Flat Washer 0.34 ID x 1.25 OD x 0.05	35317	2

Figure 12. Martin[®] Round Urethane Inspection Door Assembly, P/N 30350-018X-MW*

*X indicates stainless steel door frame (S).

Appendix A

Martin[®] Inspection Door Label



Martin[®] Inspection Door Warning Label, P/N 30382

Notes

Appendix B
Martin[®] Inspection Door Dimensions

Appendix B

Part Number	Rubber Inspection Door Dimensions—in. (mm)												
	A	B	C	D	E	F	G	H	J	K	L	M	
CYAR-0912	12.63 (321)	11.88 (302)	9.06 (230)	2.81 (71)	2.81 (71)	5.94 (151)	8.75 (222)	9.50 (241)	11.25 (286)	14.38 (365)	10.08 (256)	13.20 (335)	
CYAR-1214	14.75 (375)	14.00 (356)	11.19 (284)	2.81 (71)	2.81 (71)	9.19 (233)	12.00 (305)	12.75 (324)	14.50 (368)	16.50 (419)	13.88 (353)	15.75 (400)	
CYAR-1218	18.50 (470)	17.75 (451)	14.94 (379)	2.81 (71)	2.81 (71)	8.88 (226)	11.69 (297)	12.44 (316)	14.19 (360)	20.25 (514)	13.02 (331)	19.08 (485)	
CYAR-1824	24.44 (621)	23.69 (602)	18.88 (480)	4.81 (122)	4.81 (122)	12.94 (329)	17.75 (451)	18.50 (470)	20.25 (514)	26.19 (665)	18.95 (481)	25.02 (636)	
CYAR-2424	24.19 (614)	23.44 (595)	18.63 (473)	4.81 (122)	4.81 (122)	18.63 (473)	23.44 (595)	24.19 (614)	25.94 (659)	25.94 (659)	24.95 (634)	24.95 (634)	

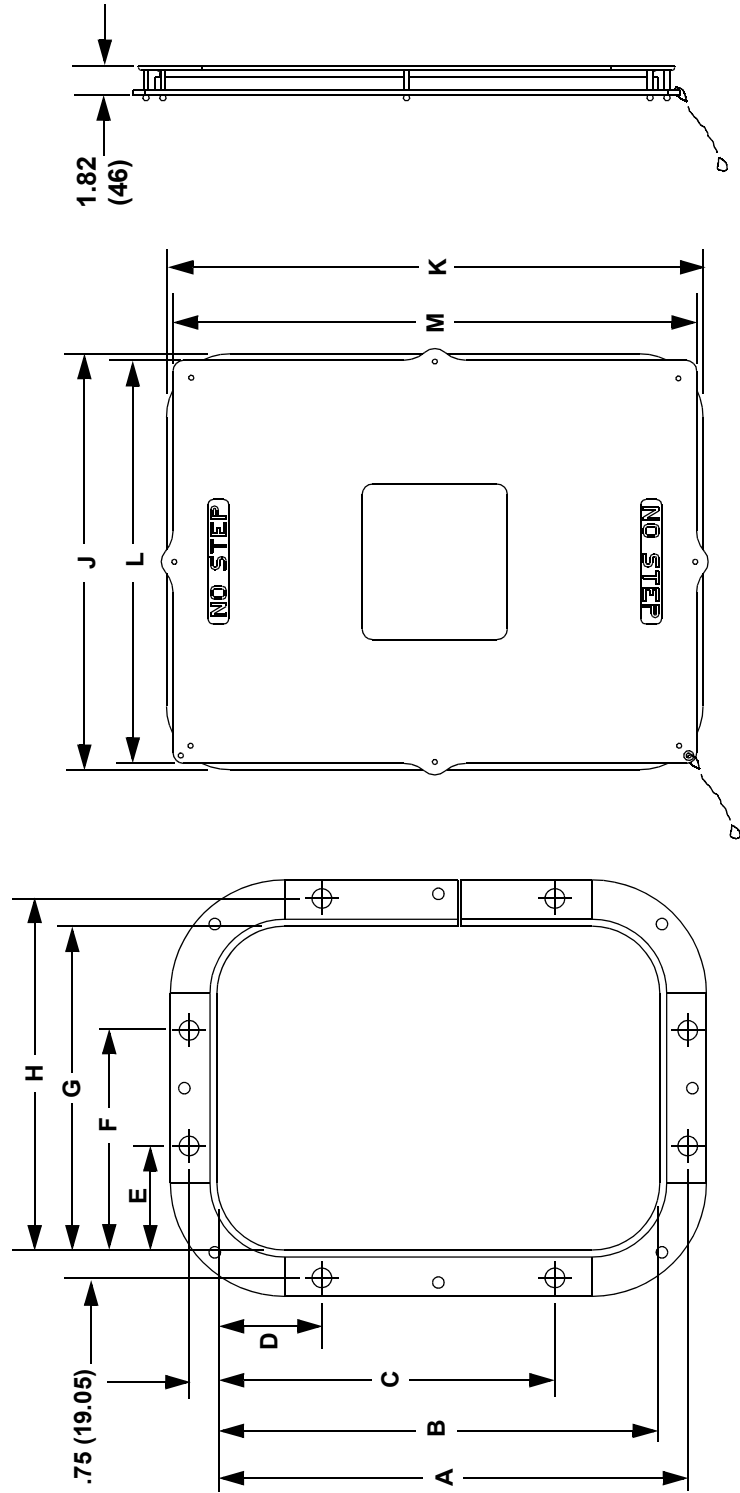

Martin® Rubber Inspection Door Dimensions (see chart above)

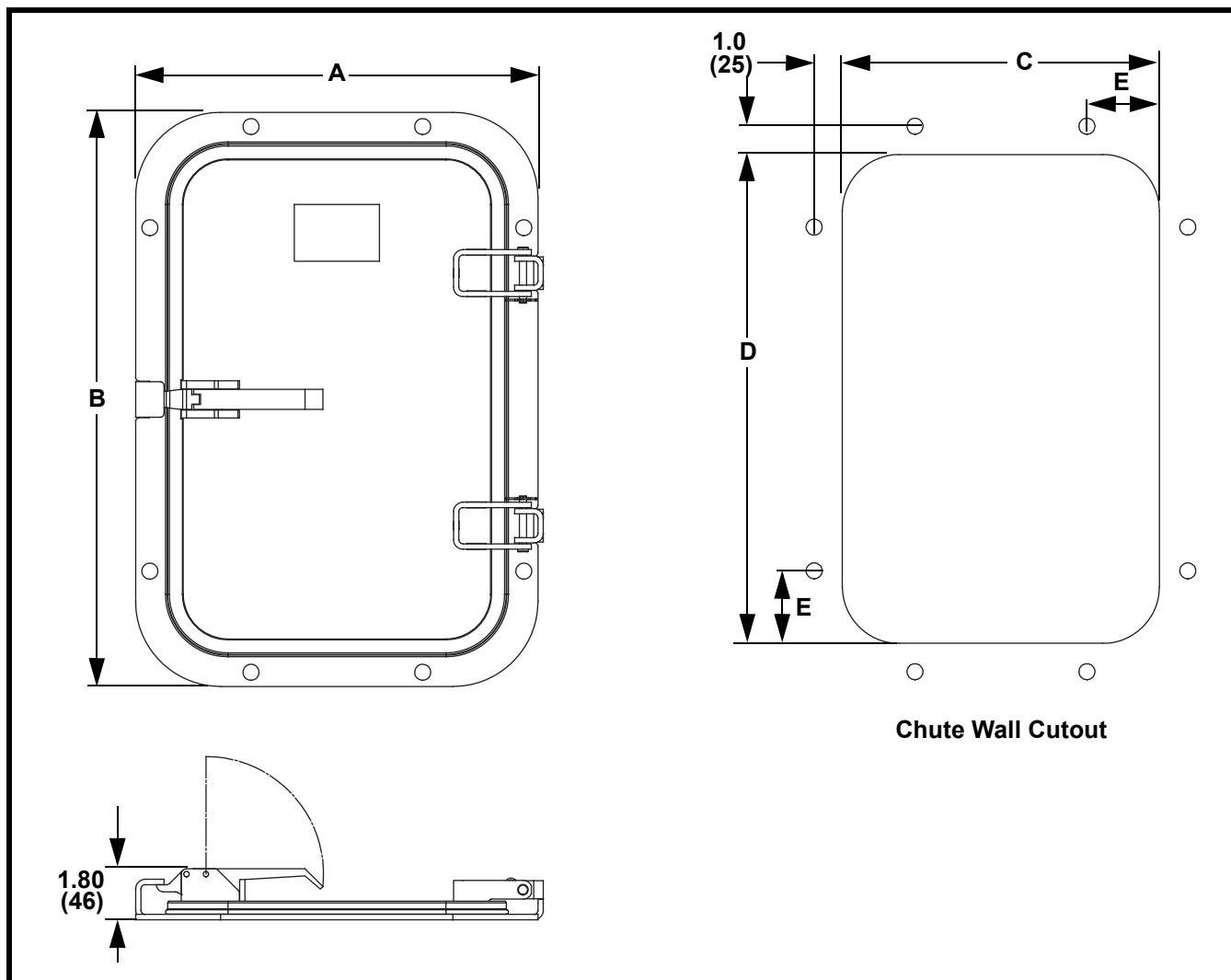

Part Number	Martin® Steel Inspection Door Dimensions in. (mm)				
	A	B	C	D	E
CYA-0912XXXXXX	11.26 (286)	14.39 (365)	8.25 (210)	11.38 (289)	2.56 (65)
CYA-1212XXXXXX	14.20 (360)	14.39 (365)	11.19 (284)	11.38 (289)	2.56 (65)
CYA-1214XXXXXX	14.20 (360)	16.26 (413)	11.19 (284)	13.25 (337)	2.56 (65)
CYA-1218XXXXXX	14.20 (360)	20.26 (514)	11.19 (284)	17.25 (438)	2.56 (65)
CYA-1616XXXXXX	18.26 (464)	18.26 (464)	15.25 (387)	15.25 (387)	2.56 (65)
CYA-1812XXXXXX	20.26 (514)	14.20 (360)	17.25 (438)	11.19 (284)	2.56 (65)
CYA-1814XXXXXX	20.26 (514)	16.26 (413)	17.25 (438)	13.25 (337)	2.56 (65)
CYA-1818XXXXXX	20.26 (514)	20.26 (514)	17.25 (438)	17.25 (438)	2.56 (65)

Appendix B

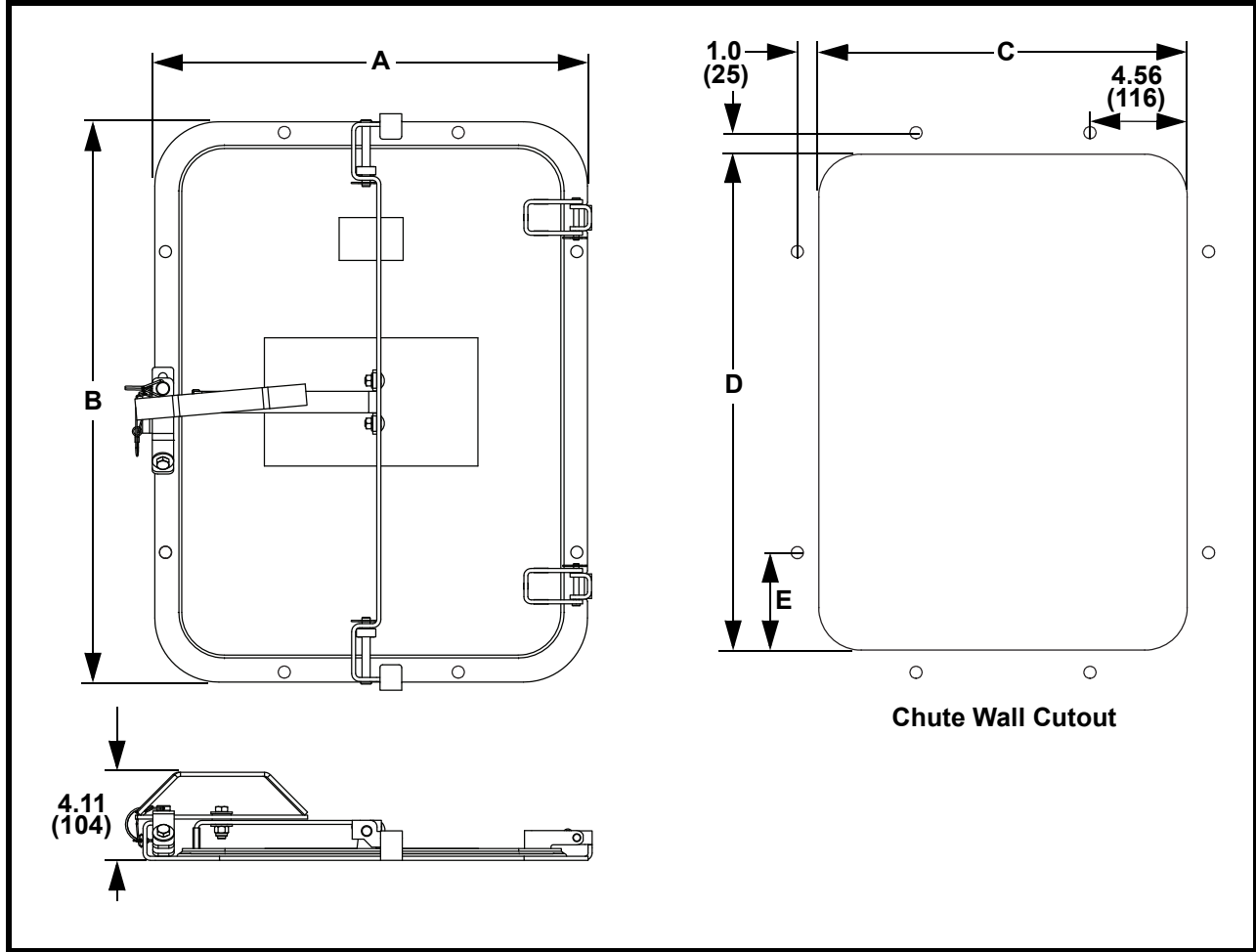

Part Number	Martin® Steel Inspection Door Dimensions in. (mm)				
	A	B	C	D	E
CYA-1824XXXXXX	20.26 (515)	26.20 (665)	17.25 (438)	23.19 (589)	4.56 (116)
CYA-2020XXXXXX	22.26 (565)	22.26 (565)	19.25 (489)	19.25 (489)	4.56 (116)
CYA-2030XXXXXX	23.50 (597)	33.50 (851)	20.25 (514)	30.25 (768)	4.56 (116)
CYA-2418XXXXXX	26.44 (672)	20.50 (521)	23.19 (589)	17.25 (438)	2.56 (65)
CYA-2424XXXXXX	26.19 (665)	26.19 (665)	22.94 (583)	22.94 (583)	4.56 (116)
CYA-2430XXXXXX	26.19 (665)	33.50 (851)	22.94 (583)	30.25 (768)	4.56 (116)
CYA-2436XXXXXX	26.19 (665)	39.50 (1003)	22.94 (583)	36.25 (921)	4.56 (116)
CYA-3018XXXXXX	33.50 (851)	20.50 (521)	30.25 (768)	17.25 (438)	2.56 (65)
CYA-3030XXXXXX	33.50 (851)	33.50 (851)	30.25 (768)	30.25 (768)	4.56 (116)
CYA-3624XXXXXX	39.50 (1003)	26.19 (665)	36.25 (921)	22.94 (583)	4.56 (116)
CYA-3636XXXXXX	39.50 (1003)	39.50 (1003)	36.25 (921)	36.25 (921)	4.56 (116)

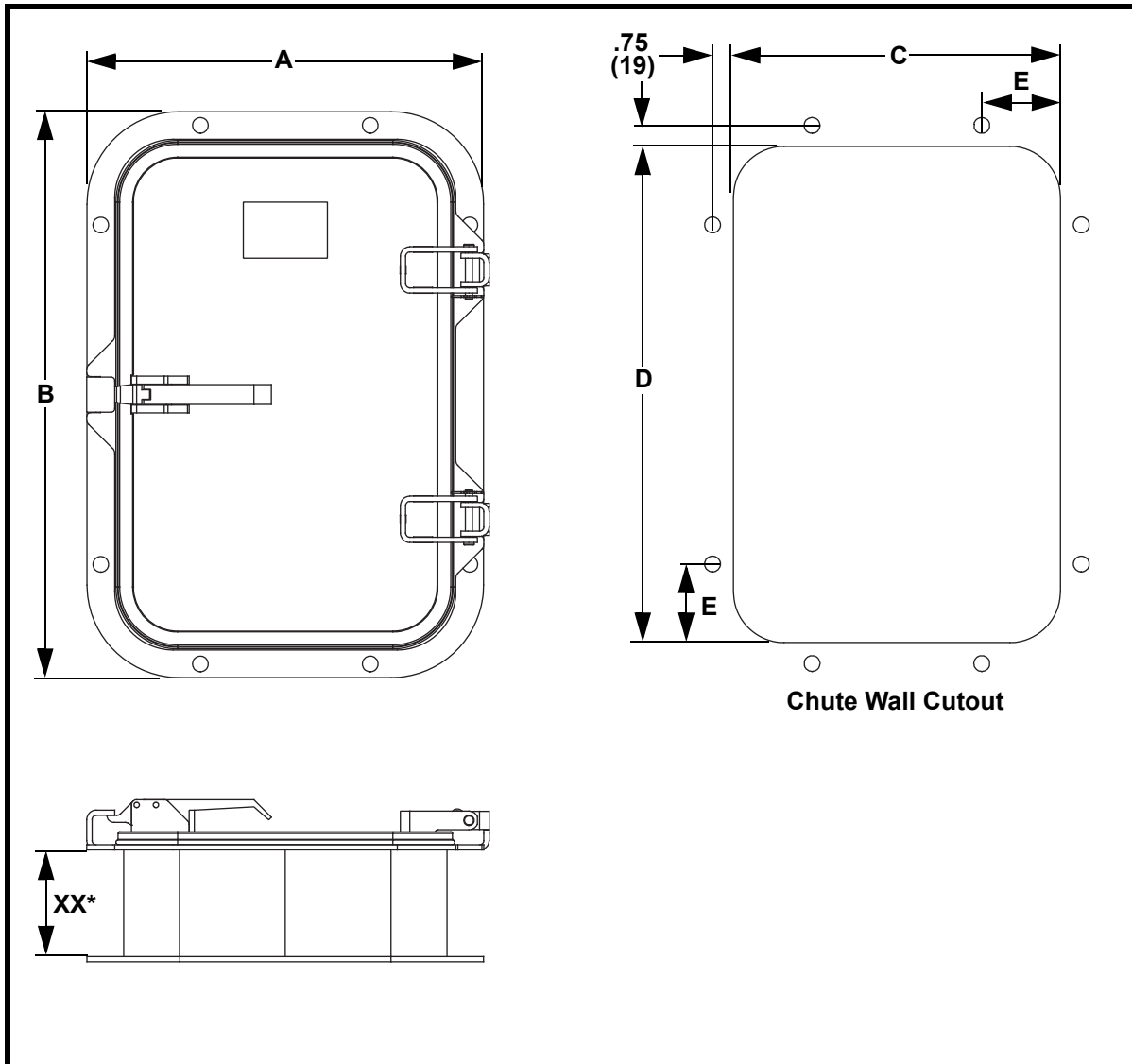

*XX indicates the frame band height in inches: 03, 04, 05, 06, 07, 08, 09, 10, 11, or 12
(08 is maximum height for -0912, -1214, and -1218 doors).

Part Number	Martin® Extended-Height Steel Inspection Door Dimensions in. (mm)				
	A	B	C	D	E
CYAE-0912-XXXXXX	11.23 (285)	14.36 (365)	8.75 (222)	11.88 (302)	2.81 (71)
CYAE-1214-XXXXXX	14.17 (360)	16.23 (412)	12.00 (305)	14.00 (356)	2.81 (71)
CYAE-1218-XXXXXX	14.17 (360)	20.23 (514)	11.69 (297)	17.75 (451)	2.81 (71)
CYAE-1824-XXXXXX	20.23 (514)	26.17 (665)	17.75 (451)	23.69 (602)	4.81 (122)
CYAE-2424-XXXXXX	25.92 (658)	25.92 (658)	23.44 (595)	23.44 (595)	4.81 (122)

Appendix B

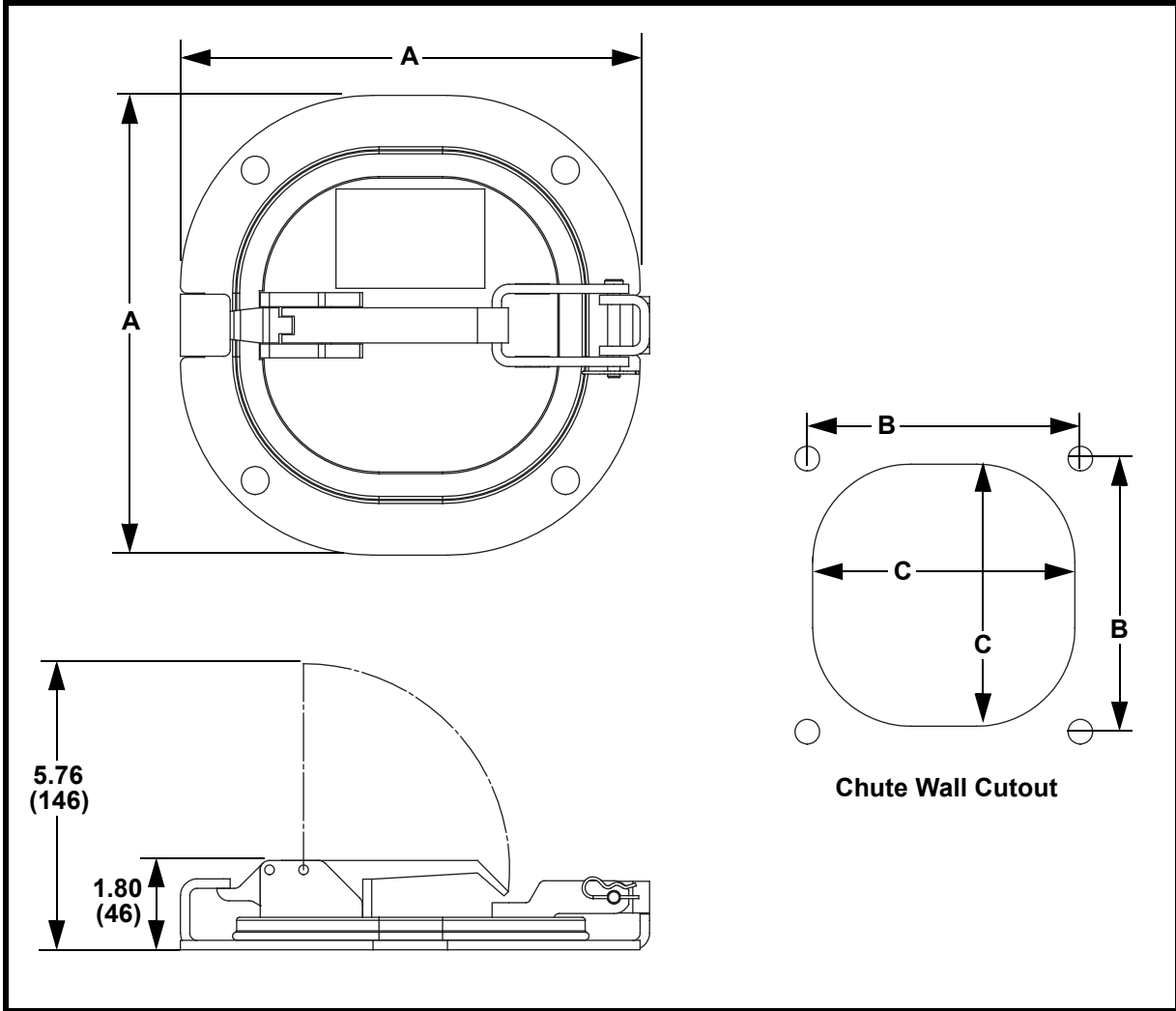

Part Number	Martin® Round Steel Inspection Door Dimensions in. (mm)		
	A	B	C
CYARD-4XXX	7.76 (197)	5.25 (133)	4.50 (114)
CYARD-6XXX	9.26 (235)	6.25 (159)	6.00 (152)
CYARD-8XXX	11.26 (286)	7.75 (197)	8.00 (203)

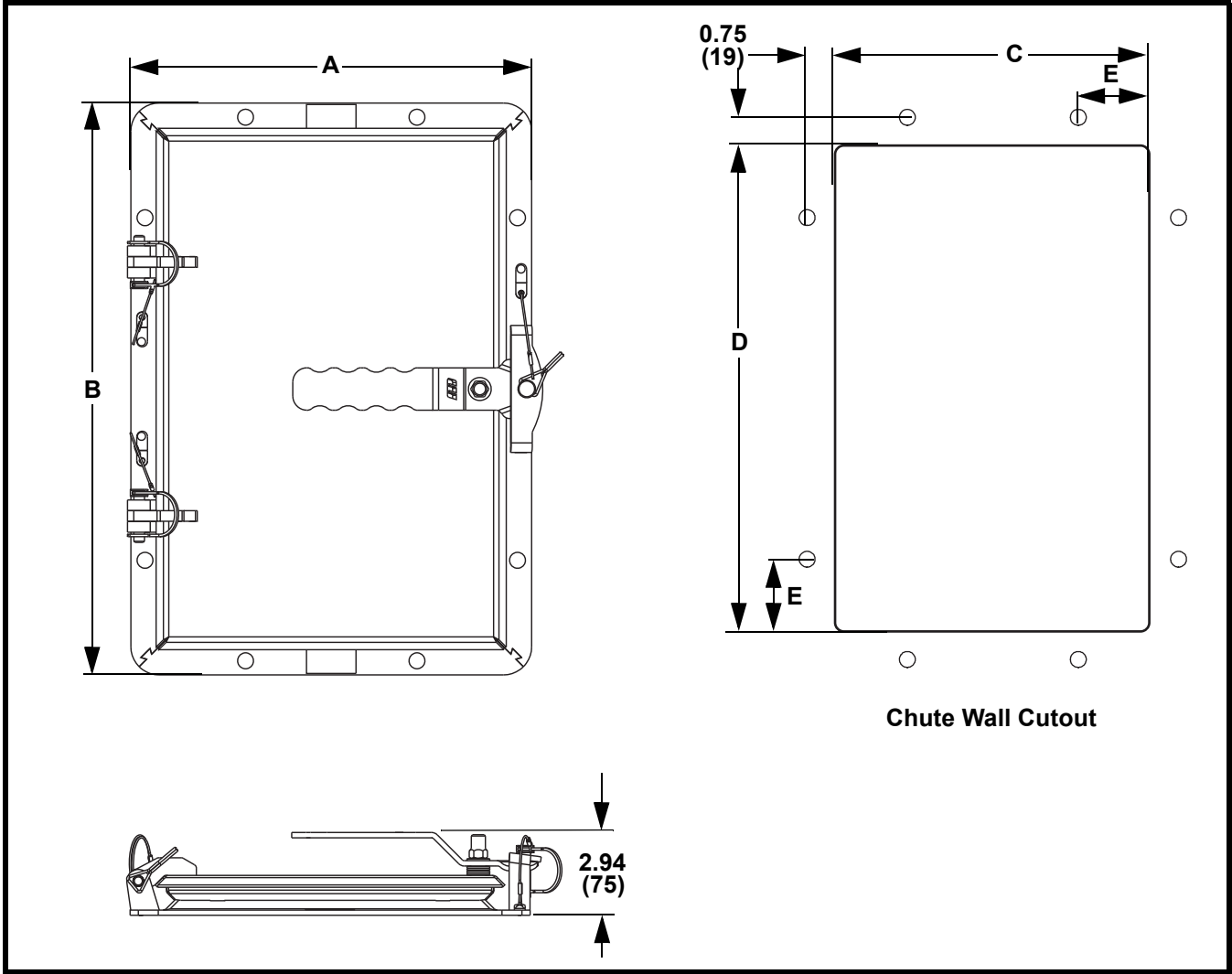

Part Number	Martin® HD Steel Inspection Door Dimensions in. (mm)				
	A	B	C	D	E
CYAHD-0912XXXXXX	11.25 (286)	14.38 (365)	8.75 (222)	11.88 (302)	2.81 (71)
CYAHD-1214XXXXXX	14.19 (360)	16.25 (413)	11.69 (297)	13.75 (349)	2.81 (71)
CYAHD-1218XXXXXX	14.19 (360)	20.25 (514)	11.69 (297)	17.75 (451)	2.81 (71)
CYAHD-1818XXXXXX	20.25 (514)	20.25 (514)	17.75 (451)	17.75 (451)	2.81 (71)
CYAHD-1824XXXXXX	20.25 (514)	26.19 (665)	17.75 (451)	23.69 (602)	4.81 (122)
CYAHD-2424XXXXXX	25.94 (659)	25.94 (659)	23.44 (595)	23.44 (595)	4.81 (122)

Appendix B

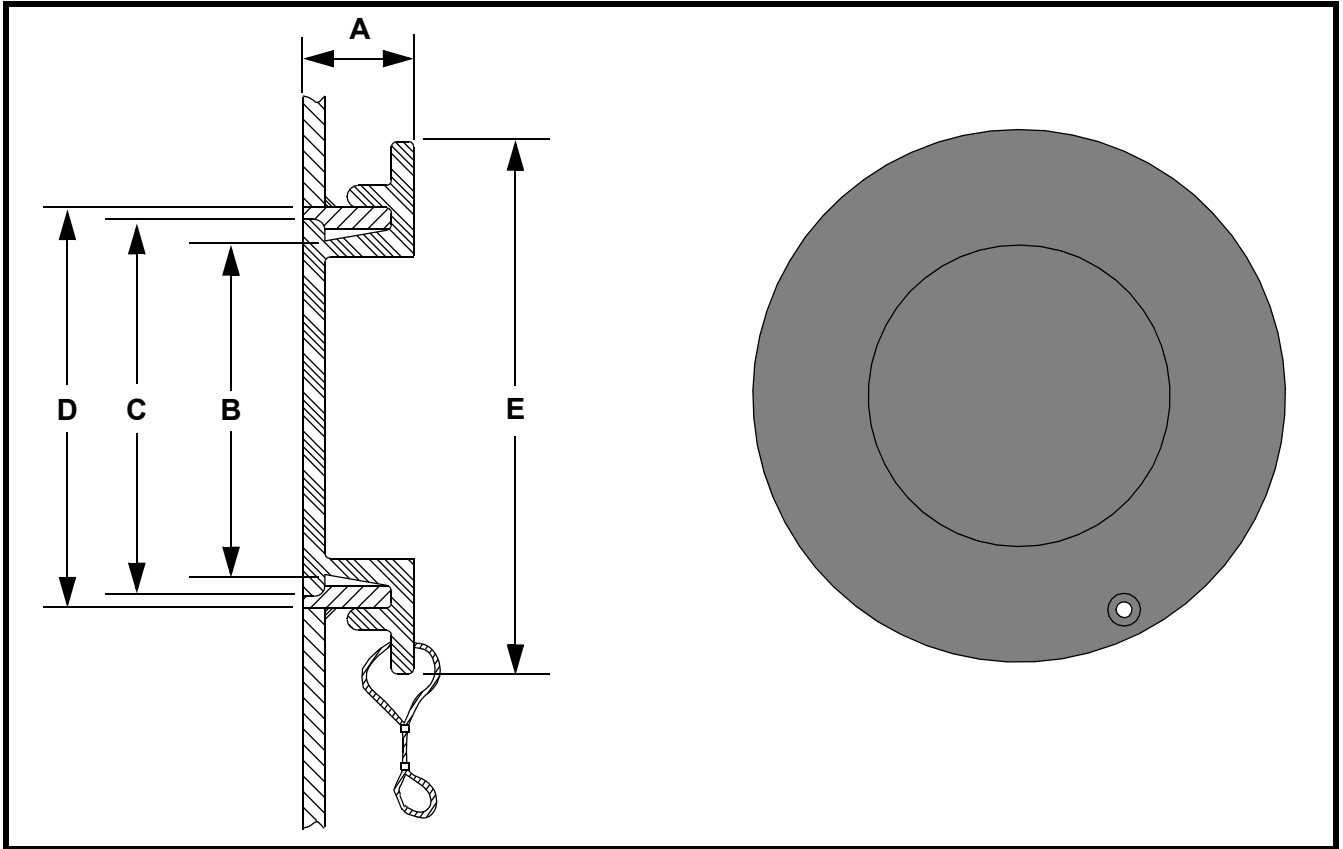

Part Number	Martin® Round Urethane Inspection Door Dimensions—in. (mm)				
	A	B	C	D	E
30350-018X-MW	1.25 (32)	7.98 (203)	8.30 (211)	8.62 (220)	10.00 (254)

Any product, process, or technology described here may be the subject of intellectual property rights reserved by Martin Engineering Company. Trademarks or service marks designated with the ® symbol are registered with the U.S. Patent and Trademark Office and may be proprietary in one or more countries or regions. Other trademarks and service marks belonging to Martin Engineering Company in the United States and/or other countries or regions may be designated with the “TM” and “SM” symbols. Brands, trademarks, and names of other parties, who may or may not be affiliated with, connected to, or endorsed by Martin Engineering Company, are identified wherever possible. Additional information regarding Martin Engineering Company’s intellectual property can be obtained at www.martin-eng.com/trademarks.

Problem Solved™ ***GUARANTEED!***

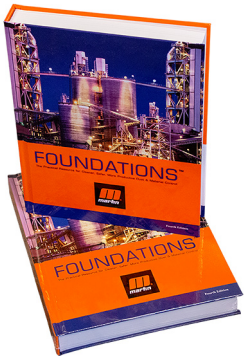

For nearly 30 years, Martin Engineering's Foundations™ Books have taught industry personnel to operate and maintain clean and safe belt conveyors. The Foundations™ Book, fourth edition, focuses on improving belt conveyors by controlling fugitive material. "The Practical Resource for Total Dust and Material Control," is a 576-page hard cover volume that provides information of value to industries where the efficient handling of bulk materials is a key to productivity and profitability.

Expanding upon the book, our Foundations™ Training Program addresses the design and development of more productive belt conveyors, and is offered in three customizable seminars. Attendees gain a better understanding of conveyor safety and performance, helping to justify upgrade investments and increase profitability.



Martin Engineering USA

One Martin Place
Neponset, IL 61345-9766 USA
800 544 2947 or 309 852 2384
Fax 800 814 1553
www.martin-eng.com

**COMPANY WITH
QUALITY SYSTEM
CERTIFIED BY DNV GL
= ISO 9001 =**