

# Martin® Conveyor Guard Installation Instructions



## ⚠ DANGER

Before installing, servicing, or adjusting the conveyor equipment, turn off and lock out/tag out all energy sources to the conveyor and conveyor accessories according to ANSI standards. Failure to do so could result in serious injury or death.

Part Number	Dim. A in. (mm)	Dim. B in. (mm)
UCBG-000813-FHXX	8 (203)	13 (330)
UCBG-001313-FHXX	13 (330)	13 (330)
UCBG-001318-FHXX	13 (330)	18 (457)
UCBG-001813-FHXX	18 (457)	13 (330)
UCBG-001818-FHXX	18 (457)	18 (457)
UCBG-002424-FHXX	24 (610)	24 (610)

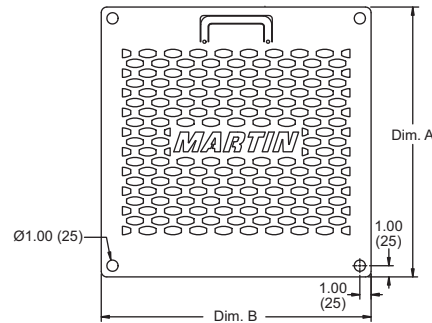

Part Number	Dim. A in. (mm)	Dim. B in. (mm)
UCBG-000824-FHXX	8 (203)	24 (610)
UCBG-001324-FHXX	13 (330)	24 (610)
UCBG-001330-FHXX	13 (330)	30 (762)
UCBG-001332-FHXX	13 (330)	32 (813)
UCBG-001336-FHXX	13 (330)	36 (914)
UCBG-001824-FHXX	18 (457)	24 (610)
UCBG-001836-FHXX	18 (457)	36 (914)
UCBG-001842-FHXX	18 (457)	42 (1067)
UCBG-002430-FHXX	24 (610)	30 (762)
UCBG-002436-FHXX	24 (610)	36 (914)
UCBG-002440-FHXX	24 (610)	40 (1016)
UCBG-002442-FHXX	24 (610)	42 (1067)
UCBG-003024-FHXX	30 (762)	24 (610)
UCBG-003030-FHXX	30 (762)	30 (762)
UCBG-003036-FHXX	30 (762)	36 (914)
UCBG-003042-FHXX	30 (762)	42 (1067)
UCBG-003618-FHXX	36 (914)	18 (457)
UCBG-003624-FHXX	36 (914)	24 (610)
UCBG-003630-FHXX	36 (914)	30 (762)
UCBG-003636-FHXX	36 (914)	36 (914)
UCBG-003642-FHXX	36 (914)	42 (1067)

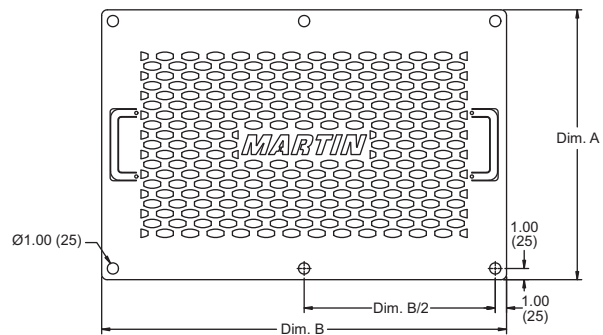

Figure 1. Conveyor Guard Dimensions

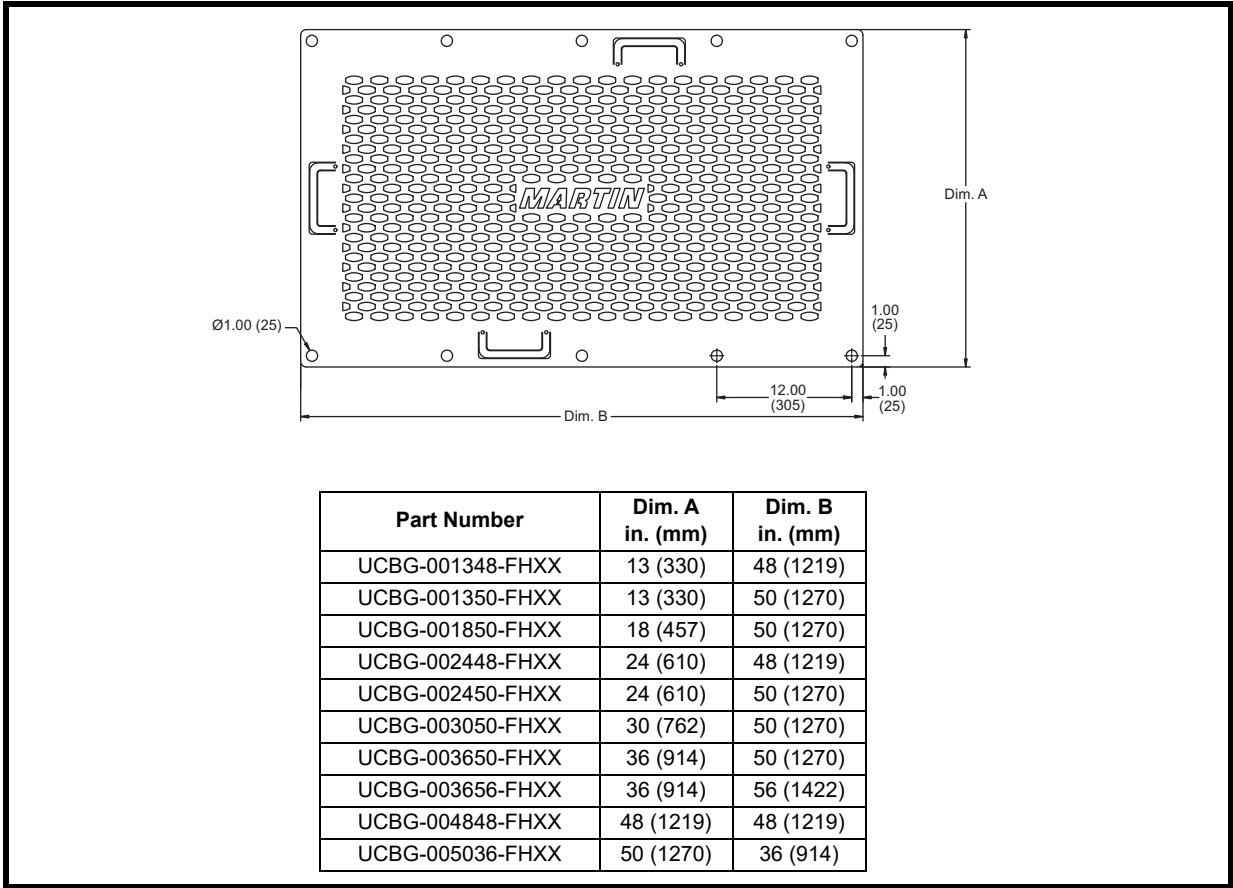

Figure 1. Conveyor Guard Dimensions

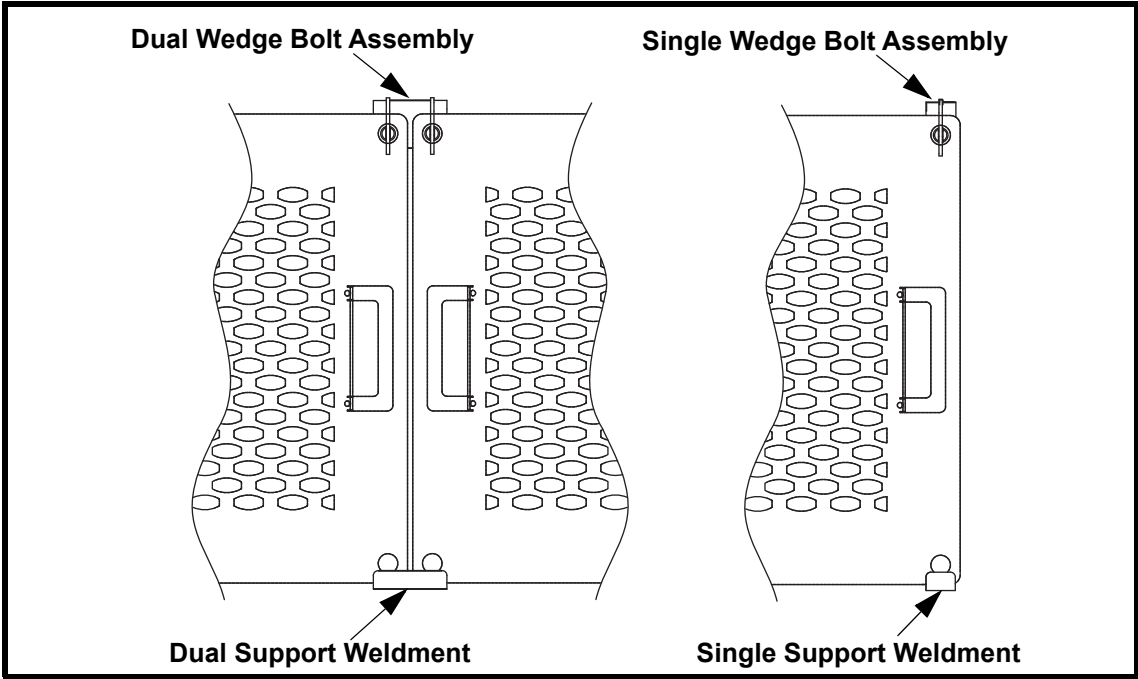
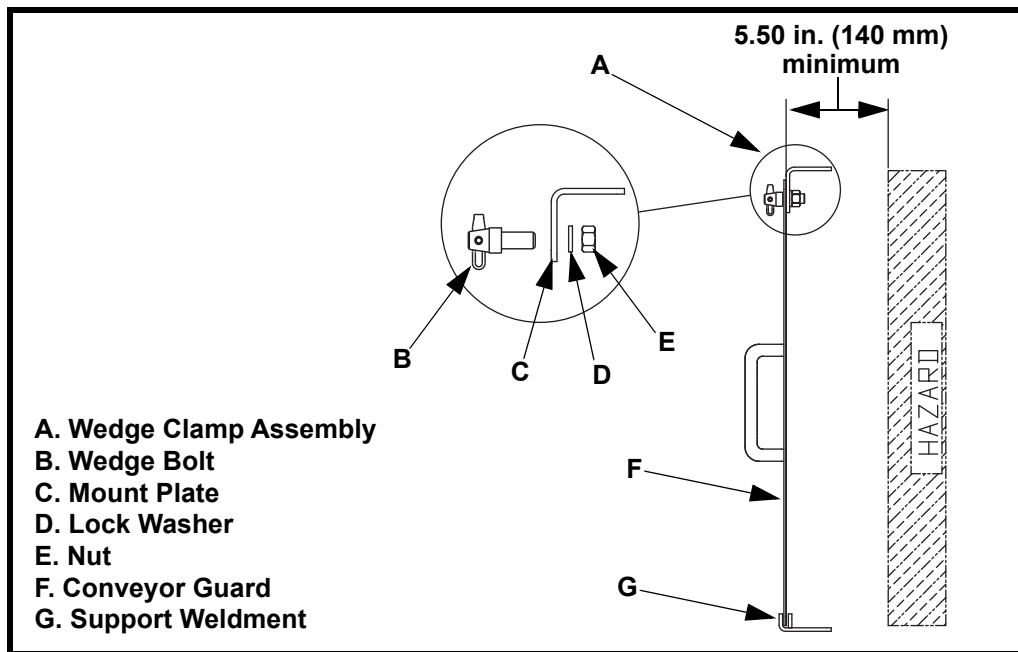

Figure 2. Installation Configurations



**Figure 3. Conveyor Guard Installation**

## IMPORTANT

Conveyor Guard must be installed a minimum of 5.50 in. (140 mm) away from hazard to conform to OSHA 29 CFR 1910.217.

## NOTE

Refer to the “Part Numbers” section of this manual for a complete list of guarding structure components available from Martin Engineering.

1. Determine location and configuration of guard(s).
2. If structure does not exist for installing mounting plates, use the best available field resources and methods to fabricate a support structure for the conveyor guards.
3. Using the conveyor guard as a template, mark location of mounting holes. Refer to Figure 1.
4. Align mount plates with locations marked in step 3.
5. Bolt or weld mount plates (C) to support structure.
6. Install wedge bolt (B) on mount plate (C) and fasten with lock washer (D) and nut (E).
7. Install conveyor guard (F) on wedge clamp assemblies (A).
8. Determine location of support weldments (G).
9. Bolt or weld support weldments (G) to structure.
10. Integrated handles can be bent into a working position where needed:
  - a. Make sure labels and logo will be visible and properly positioned when handle is in working position.
  - b. Insert a punch into hole at base of handle.
  - c. Slowly bend each side of the handle upward. Alternate from one side to the other frequently when bending to avoid distorting handle.
  - d. Handles can be bent into final position by hand.
11. Make sure all fasteners are tight and conveyor guards do not interfere with operation of conveyor.

# Part Numbers

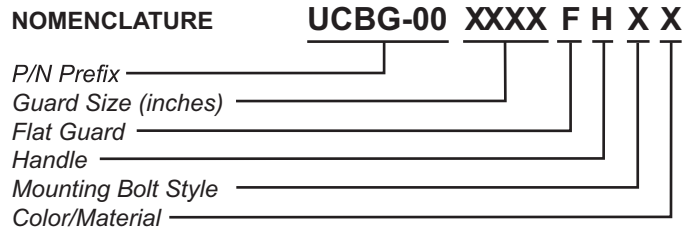

**MOUNTING BOLT STYLE**

- B:** Includes 4 Wedge Bolts, Nuts, and Lock Washers
- D:** Includes 1 Dual Wedge Bolt Assembly and 1 Support Weldment
- S:** Includes 2 Single Wedge Bolt Assemblies and 2 Support Weldments

**COLOR/MATERIAL**

- Y:** Safety Yellow
- O:** Martin® Orange
- P:** Pink
- C:** 304 Stainless Steel

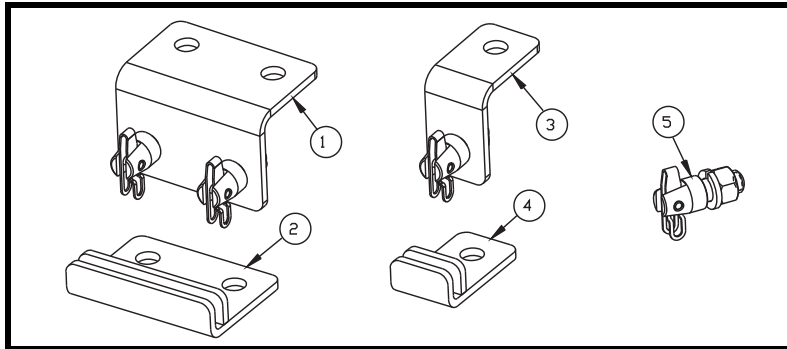

**Mounting Accessory Part Numbers**

Assembly P/N	Item	Description	Part Number	Qty.
UCBG-00XXXX-FHBX	1	Dual Wedge Bolt Assembly	UCBG-001002	4
	2	Dual Support Weldment	UCBG-001102	1
UCBG-00XXXX-FHDX	3	Single Wedge Bolt Assembly	UCBG-001001	2
	4	Single Support Weldment	UCBG-001101	2
UCBG-00XXXX-FHSX	5	Wedge Bolt	UCBG-001003	1

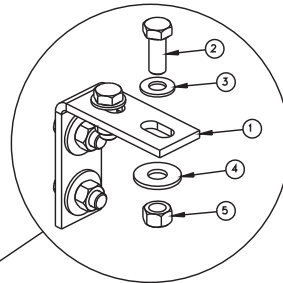
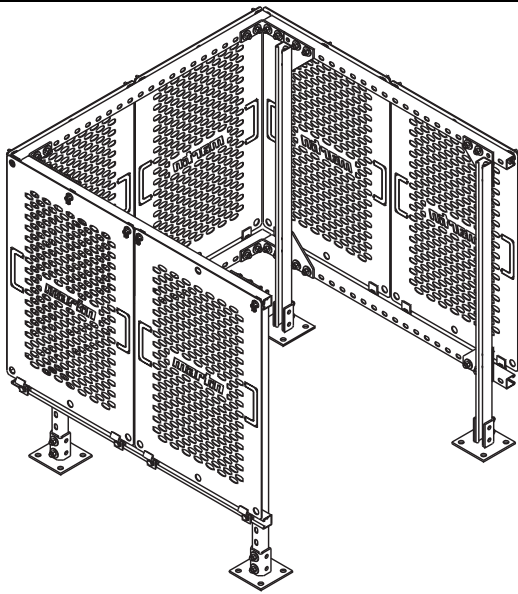

**P/N 38910-07**

**P/N 36470-XXX**

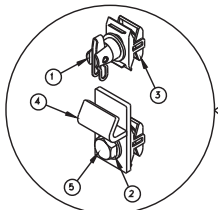
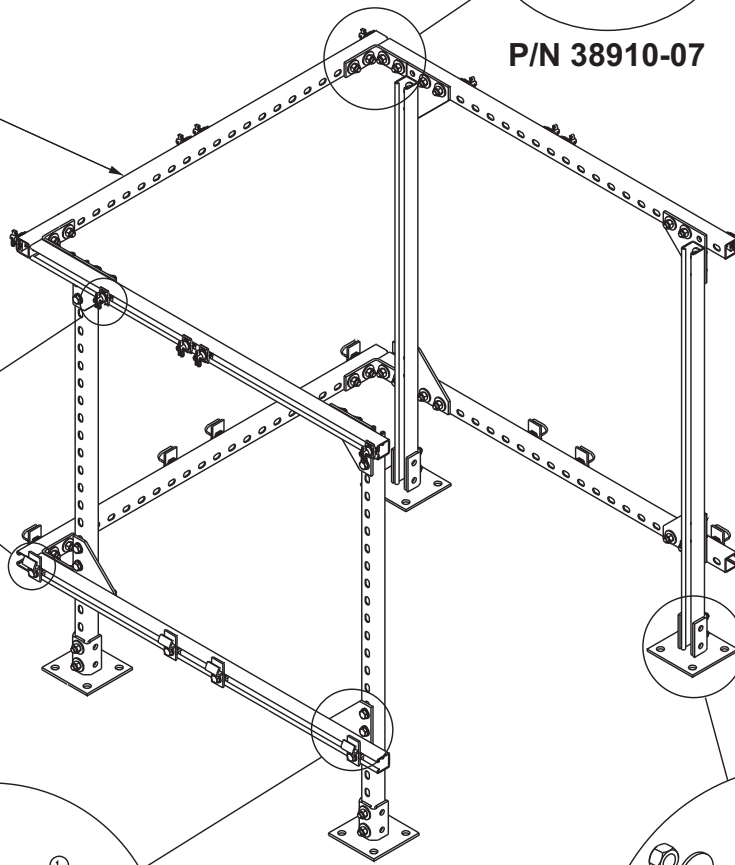

**P/N 38910-01**

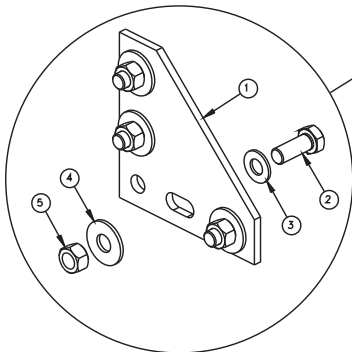

**P/N 38910-06**

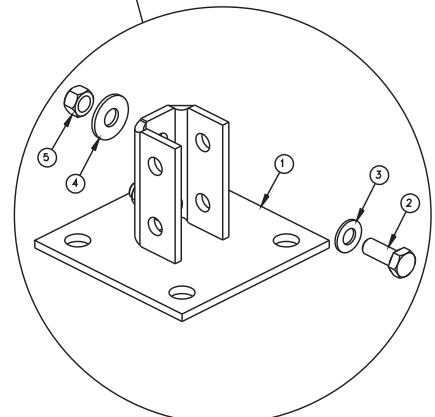

**P/N 38910-05**

**Barrier Guard Mounting Kit, P/N 38910-01**

Item	Description	Part No.	Qty.
1	Wedge Bolt 1/2-13NC x 1 ZP	UCBG-001003	2
2	Washer Compression 1/2	11750	4
3	Nut Tab-Lock	38852	4
4	Barrier Guard Panel Hanger Weldment	38908	2
5	Screw HHC 1/2-13NC x 1-1/4 ZP	13835	2

**Mounting Plate with Hardware, P/N 38910-05**

Item	Description	Part No.	Qty.
1	Mounting Plate	39038	1
2	Screw HHC 1/2-13NC x 1-1/4 ZP	13835	2
3	Washer Compression 1/2	11750	2
4	Washer Flat 1/2 ZP	17328	2
5	Nut Hex 1/2-13NC ZP	11771	2

**Slotted Plate with Hardware, P/N 38910-06**

Item	Description	Part No.	Qty.
1	Slotted Plate	39039	1
2	Screw HHC 1/2-13NC x 1-1/4 ZP	13835	4
3	Washer Compression 1/2	11750	4
4	Washer Flat 1/2 ZP	17328	4
5	Nut Hex 1/2-13NC ZP	11771	4

**L-Bracket with Hardware, P/N 38910-07**

Item	Description	Part No.	Qty.
1	L-Bracket	39040	1
2	Screw HHC 1/2-13NC x 1-1/4 ZP	13835	4
3	Washer Compression 1/2	11750	4
4	Washer Flat 1/2 ZP	17328	4
5	Nut Hex 1/2-13NC ZP	11771	4

**Slotted Channel, P/N 36470-XXX**

Part No.	Length (in.)
36470	12
36470-14	14
36470-30	30
36470-60	60
36470-72	72
36470-120	120

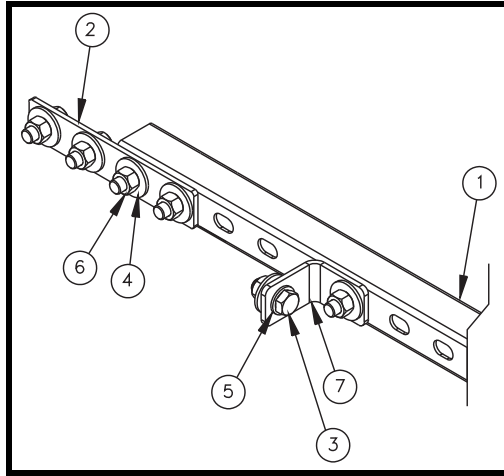

**Slotted Channel with Mounting Hardware for use on Standard Style Supports, P/N 38910-02**

Item	Description	Part No.	Qty.
1	Channel with Slotted Holes	36470-120	2
2	Splice Plate	38909	2
3	Washer Compression 1/2	11750	16
4	Washer Flat 1/2 ZP	17328	16
5	Screw HHC 1/2-13NC x 1-1/4 ZP	13835	16
6	Nut Hex 1/2-13NC ZP	11771	16
7	Mount Plate	UCBG-001001-P	4

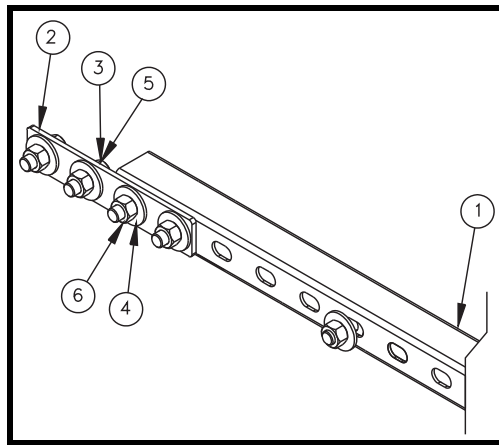

**Slotted Channel with Mounting Hardware for use on EVO<sup>®</sup> Style Supports, P/N 38910-03**

Item	Description	Part No.	Qty.
1	Channel with Slotted Holes	36470-120	2
2	Splice Plate	38909	2
3	Washer Compression 1/2	11750	12
4	Washer Flat 1/2 ZP	17328	12
5	Screw HHC 1/2-13NC x 1-1/4 ZP	13835	12
6	Nut Hex 1/2-13NC ZP	11771	12

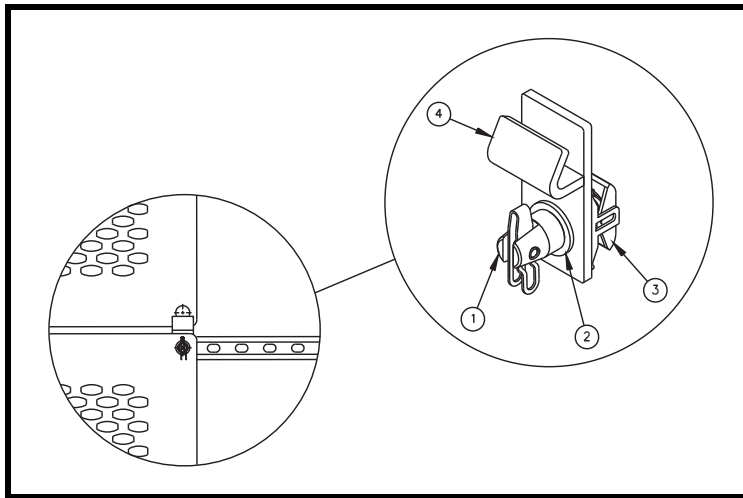

### Double Barrier Guard Mounting Kit, P/N 38910-08

Item	Description	Part No.	Qty.
1	Wedge Bolt 1/2-13NC x 1 ZP	UCBG-001003	2
2	Washer Compression 1/2	11750	2
3	Nut Tab-Lock	38852	2
4	Barrier Guard Panel Hanger Weldment	38908-L	2

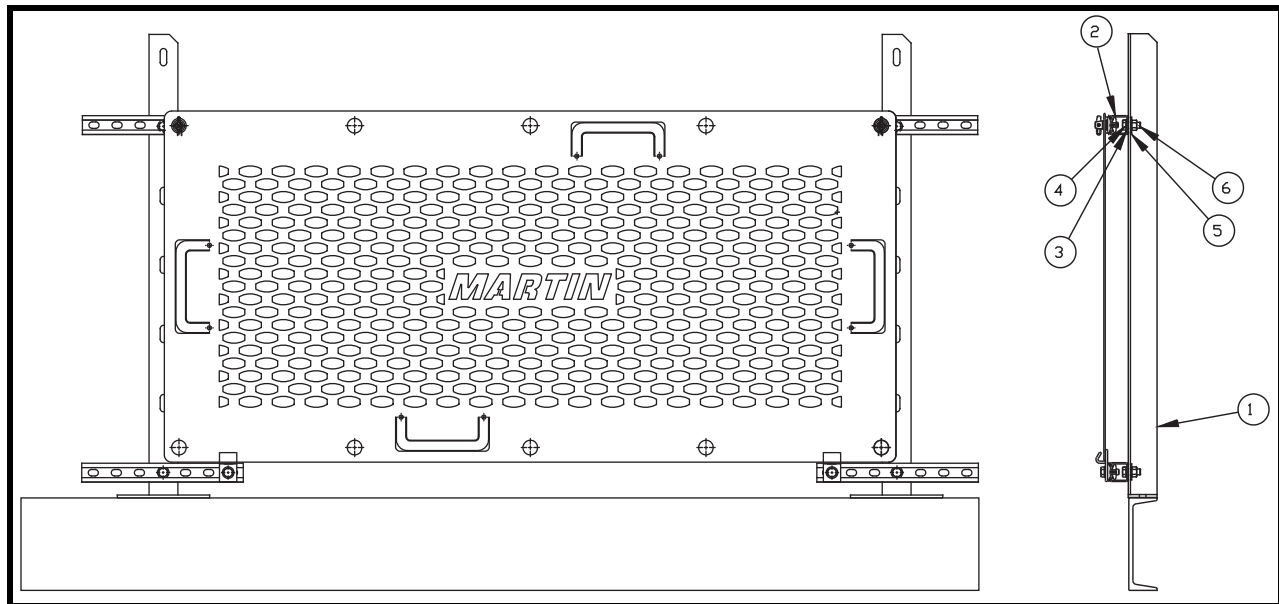

### Upright Stand Assembly, P/N 38910-09

Item	Description	Part No.	Qty.
1	Upright Stand Weldment	39083-W	1
2	Channel with Slotted Holes	36470-14	2
3	Washer Compression 1/2	11750	2
4	Screw HHC 1/2-13NC x 1-1/4 ZP	13835	2
5	Washer Flat 1/2 ZP	17328	2
6	Nut Hex 1/2-13NC ZP	11771	2