

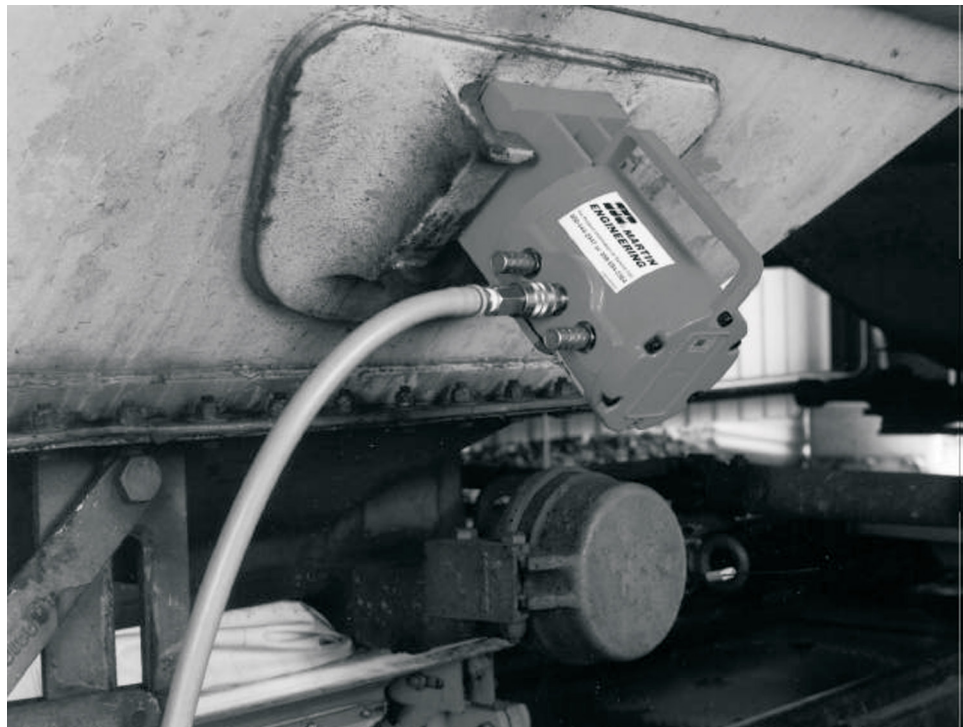

Martin® Non-Impacting Railcar Vibrator

[Go to Martin® Non-Impacting Railcar Vibrator web page](#)



***Operator's Manual
M3559***

Important

MARTIN ENGINEERING HEREBY DISCLAIMS ANY LIABILITY FOR: DAMAGE DUE TO CONTAMINATION OF THE MATERIAL; USER'S FAILURE TO INSPECT, MAINTAIN AND TAKE REASONABLE CARE OF THE EQUIPMENT; INJURIES OR DAMAGE RESULTING FROM USE OR APPLICATION OF THIS PRODUCT CONTRARY TO INSTRUCTIONS AND SPECIFICATIONS CONTAINED HEREIN. MARTIN ENGINEERING'S LIABILITY SHALL BE LIMITED TO REPAIR OR REPLACEMENT OF EQUIPMENT SHOWN TO BE DEFECTIVE.

Observe all safety rules given herein along with owner and Government standards and regulations. Know and understand lockout/tagout procedures as defined by American National Standards Institute (ANSI) z244.1-1982, *American National Standard for Personnel Protection - Lockout/Tagout of Energy Sources - Minimum Safety Requirements* and Occupational Safety and Health Administration (OSHA) Federal Register, Part IV, 29 CFR Part 1910, *Control of Hazardous Energy Source (Lockout/Tagout); Final Rule*.

The following symbols may be used in this manual:



Danger: Immediate hazards that will result in severe personal injury or death.



Warning: Hazards or unsafe practices that could result in personal injury.



Caution: Hazards or unsafe practices that could result in product or property damages.



Important: Instructions that must be followed to ensure proper installation/operation of equipment.



Note: General statements to assist the reader.

Table of Contents

Section	Page
List of Figures	ii
Introduction	1
General	1
References	1
Safety	1
Materials required	1
Before Installing Vibrator	2
Installing/Operating Vibrator	3
After Installing Vibrator	4
Weekly Maintenance	4
Troubleshooting	5
Part Numbers	6

List of Figures

Figure	Title	Page
1	Martin® Non-Impacting Railcar Vibrator Assembly, P/N 36889	7
2	Air/Exhaust Inlet Label Placement	8
3	Vibrator Warning Tag, P/N 34071	9

Introduction

General

Martin® Non-Impacting Railcar Vibrators provide force to activate the free flow of sticky, coarse, high-moisture materials in railcars. The vibrators require no maintenance when used with filtered, regulated and lubricated air.

Vibrators are quiet, lightweight, and are used on the sloped portion of railcars.

This manual covers installing and operating the Martin® Non-Impacting Railcar Vibrators. For assistance installing the vibrators or for other applications, call Martin Engineering or a representative.

References

The following documents are referenced in this manual:

- American National Standards Institute (ANSI) z244.1-1982, *American National Standard for Personnel Protection - Lockout/Tagout of Energy Sources - Minimum Safety Requirements*, American National Standards Institute, Inc., 1430 Broadway, New York, NY 10018.
- Federal Register, Volume 54, Number 169, Part IV, 29 CFR Part 1910, *Control of Hazardous Energy Source (Lockout/Tagout); Final Rule*, Department of Labor, Occupational Safety and Health Administration (OSHA), 32nd Floor, Room 3244, 230 South Dearborn Street, Chicago, IL 60604.

Safety

All safety rules defined in the above documents, and all owner/employer safety rules, must be strictly followed when working on the Martin® Non-Impacting Railcar Vibrator.

Materials required

For proper operation of this equipment:

- Filter, regulator, lubricator located within 25 feet of vibrator.
(set pressure at 40 psi minimum/80 psi maximum and set lubricator set to deliver 1–2 drops of oil per minute)
- 1/2 inch hose minimum.

Before Installing Vibrator

IMPORTANT

The delivery service is responsible for damage occurring in transit. Martin Engineering CANNOT enter claims for damages. Contact your transportation agent for more information.

1. Inspect shipping container for damage. Report damage to delivery service immediately and fill out delivery service's claim form. Keep any damaged goods subject to examination.
2. Remove vibrator from shipping container.
3. If anything is missing, contact Martin Engineering or representative.
4. Make sure mounting surface and vibrator are clean and free of debris.

Installing/Operating Vibrator

CAUTION

Abusing or handling vibrator carelessly will accelerate wear and shorten its life.

To install the vibrator:

1. Place male wedge bracket into female bracket of railcar.

IMPORTANT

Piston vibrators produce linear vibration best applied to wet, sticky material adhering to a railcar wall. The object is to move the wall back and forth to dislodge the material.

2. Connect air lines to vibrator with ball valve to quick-start vibrator.
3. Make sure vibrator has a clean FRL setup within 25 feet of vibrator and connect air line.
4. Set pressure to 40–80 psi operating range.
5. Set oil to 1–2 drops per minute.
6. Vibrator needs full air pressure from start with ball valve operation. Fully open ball valve to start vibrator.

NOTE

The Martin® Non-Impacting Railcar Vibrator requires 40 psi minimum/80 psi maximum to start and operate vibrator.

IMPORTANT

Martin Engineering recommends thin grade air motor oil in vibrators.

IMPORTANT

It is strongly recommended to use size 5 micrometer filters due to the small tolerance between piston and bore.

IMPORTANT

Air line and FRL kit need to be adequate for individual vibrator.

IMPORTANT

Verify lubricator is working while unit is on. Lack of lubrication will terminate vibrator.

NOTE

Vibrator operates at temperatures of 30°F (-1°C) and above.

After Installing Vibrator

▲ WARNING

The Martin® Non-Impacting Railcar Vibrator operates at a decibel level of under 85 dba. Hearing protection is not required at this level. However, certain products vibrating in the hopper car may cause the decibel level to rise. Martin Engineering recommends testing the decibel level when operating on hopper. If decibel level exceeds 85 dba, hearing protection is required.

Weekly Maintenance

IMPORTANT

Read entire section before beginning work.

1. Check vibrator mounts for structural damage.
2. Make sure all fasteners are tight. Tighten if necessary. See engineering drawing for torque specs.
3. Check mufflers for dirt or oil accumulation by removing the screen. Clean mufflers with a petroleum solvent such as kerosene or WD-40.
4. Check air filter for accumulation of dirt. If clogged, wash out or replace.
5. Install air line.
6. Check lubricator for sufficient oil in the container.
7. Wipe all labels clean. If labels are not readable, contact Martin Engineering or a representative for replacements.
8. Restart vibrator.

IMPORTANT

It is extremely important to keep lubricator filled with oil. Vibrator will be damaged if lubricator runs out of oil. Set lubricator at a rate of 1–2 drops per minute.

Troubleshooting

Troubleshooting

If you are experiencing problems with the Martin® Non-Impacting Railcar Vibrator, see below.

Symptom	Corrective Action
Vibrator not running	<p>Verify air pressure. 40 psi min./80 psi max. Vibrator needs full air pressure on start-up with ball valve operation. No air pressure. Make sure air is on and being supplied to vibrator. Check lubrication. Vibrator may not operate at temperatures below 30°F.</p>
Vibrator not performing full-speed	<p>Mufflers dirty. Clean or replace mufflers. Check air pressure and air line. Air line and components must be proper volume for individual vibrator. Ensure that flexible tube is not bent. Make sure inside diameter of air pressure supply pipe is large enough and not too long. Check inside diameter of valves used. Make sure there are not too many air consumers being operated at the same time with one air line. Consumers should be selectively controlled. Check lubrication.</p>
Vibrator not starting (manually driven)	<p>The piston needs to be supplied with full pressure (40 psi min./80 psi max.) upon start-up. Open the valve as quickly as possible or make use of the solenoid valves. Electrically- or pneumatically-driven valves are recommended. Insufficiently large tube or valve diameter may cause similar problems. Check lubrication.</p>
Vibrator not starting	<p>Gumming of oil causes parts to stick together. Add 10 drops of kerosene into air inlet to dissolve the gumming oil. Air pressure supply blockage: Check muffler or hose for clogging. If clogged, wash out with kerosene and replace. Check lubrication.</p>

NOTE

Vibrator operates at temperatures of 30°F and above.

Part Numbers

This section provides product names and corresponding part numbers for Martin® Non-Impacting Railcar Vibrator and related equipment. Please reference part numbers when ordering parts.

Railcar Vibrator

Railcar Vibrator Assembly: P/N 36889.

Accessories

Female Wedge Bracket (LBF): P/N 12735

Control Line Kit: P/N 39504

Oil

Air Motor Oil (qt): P/N 14766

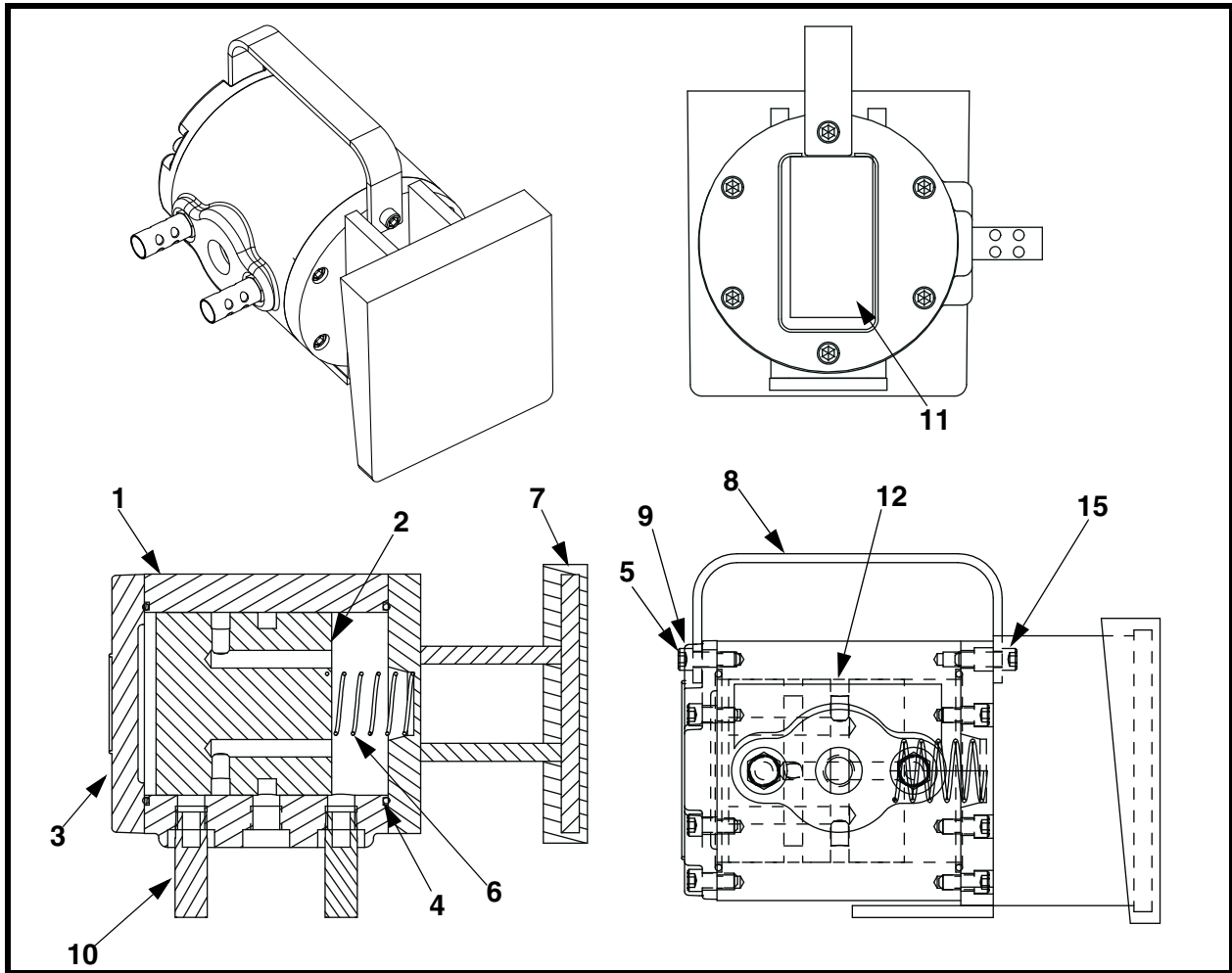

Figure 1. Martin® Non-Impacting Railcar Vibrator Assembly, P/N 36889

Item	Description	Part No.	Qty
1	Piston Vibrator Body	36888-F	1
2	Piston	36896-HG	1
3	Top Cover (Machined)	36400	1
4	O-Ring #242 3.984 ID x .139 CS	36404	2
5	Screw SHC 5/16-18NC x 1	501246-YNP	11
6	Spring 1.205 ID x .072 WD	29684-05	1
7	Mount Bracket w/Polyurethane Wedge	36891	1
8	Handle	36892	1
9	Compression Washer 5/16	31401	2
10	Muffler 3/8	210316	2
11	Serial Number Label	CG-100418	1
12	Exhaust Inlet Label	36913	1
13 (NS)	Plastic Plug 3/8 NPT (Push-in)	606013	6
14 (NS)	Operator Manual	M3559	1
15	Screw SHC 5/16-18NC x 1-1/2	501248-YNP	1
16 (NS)	OSHA Hearing Protection Tag	34085	1

NS = Not shown

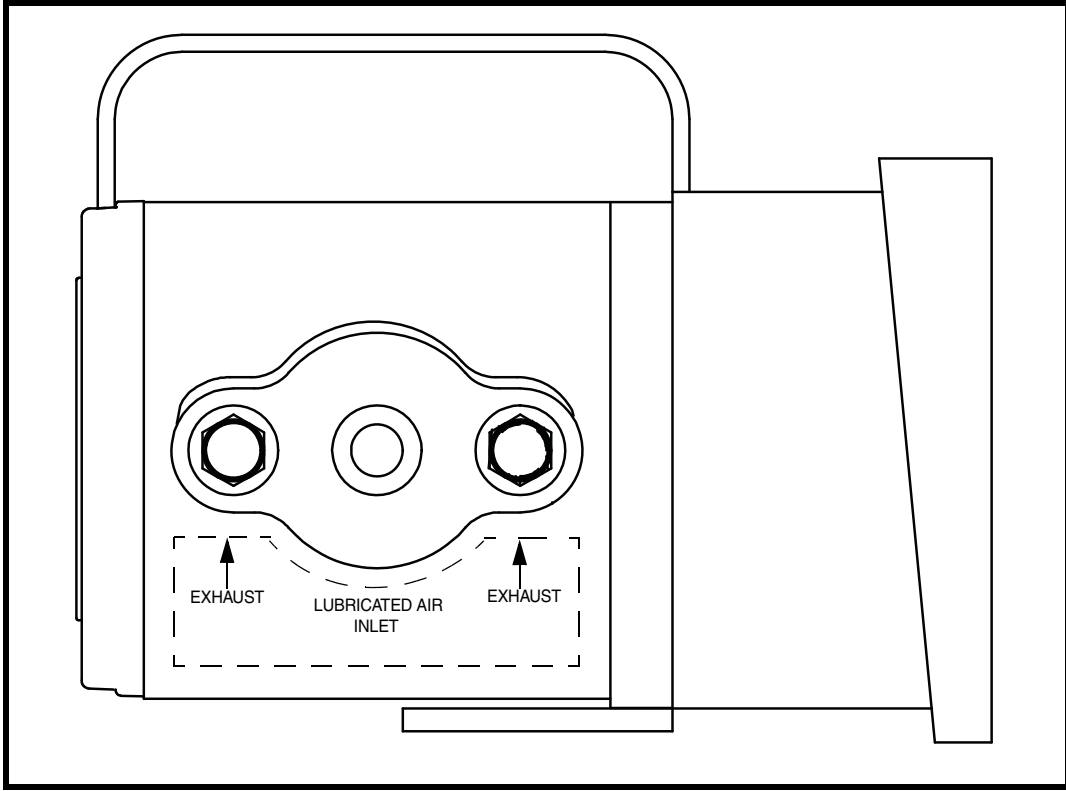

Figure 2. Air/ Exhaust Inlet Label Placement

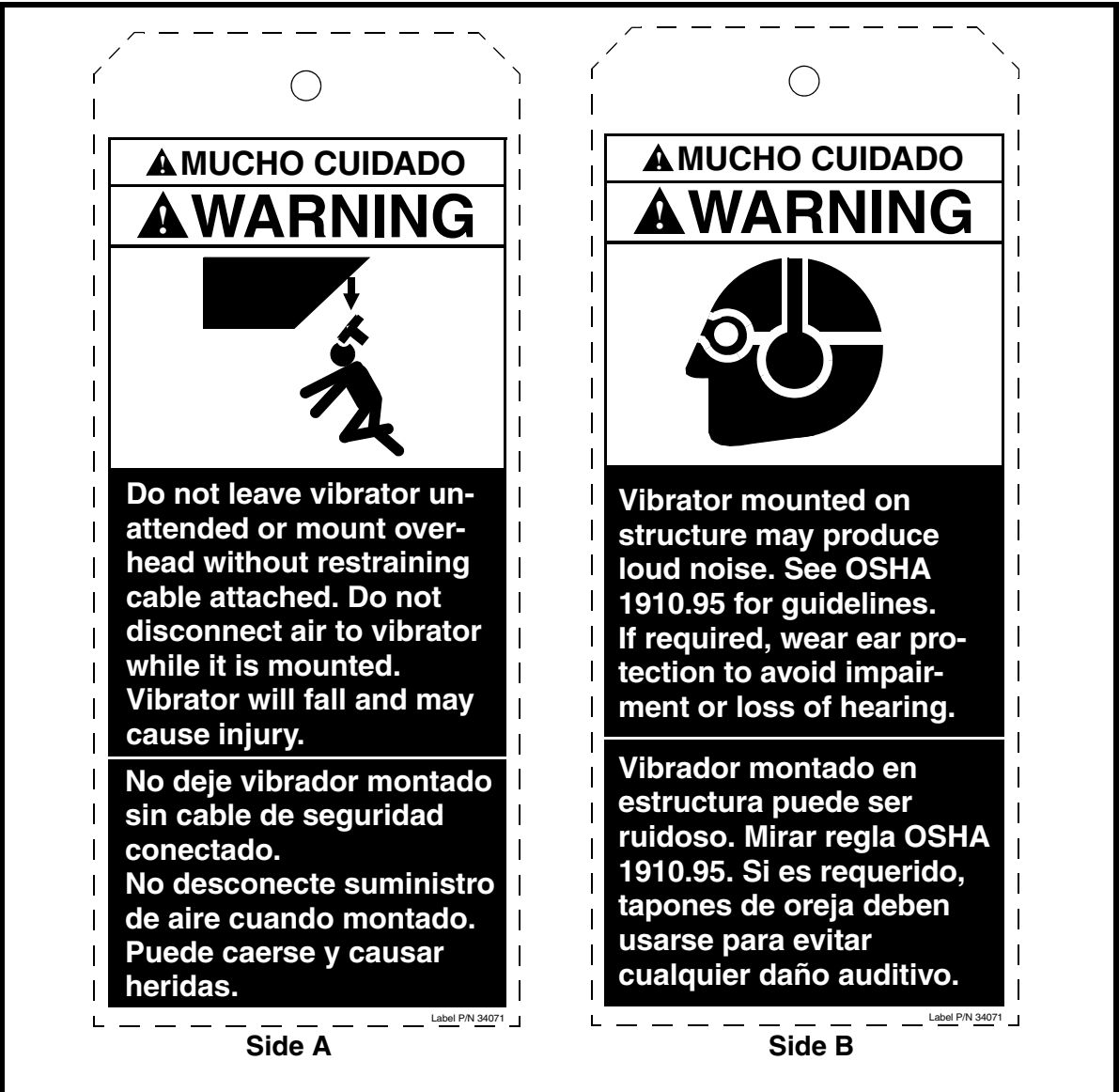
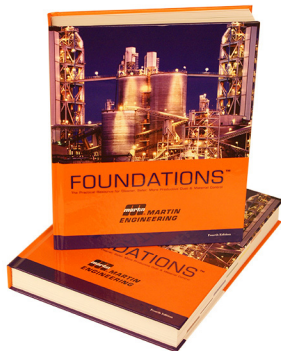

Figure 3. Vibrator Warning Tag, P/N 34071

Any product, process, or technology described here may be the subject of intellectual property rights reserved by Martin Engineering Company. Trademarks or service marks designated with the ® symbol are registered with the U.S. Patent and Trademark Office and may be proprietary in one or more countries or regions. Other trademarks and service marks belonging to Martin Engineering Company in the United States and/or other countries or regions may be designated with the “TM” and “SM” symbols. Brands, trademarks, and names of other parties, who may or may not be affiliated with, connected to, or endorsed by Martin Engineering Company, are identified wherever possible. Additional information regarding Martin Engineering Company’s intellectual property can be obtained at www.martin-eng.com/trademarks.

Problem Solved™ GUARANTEED!



For nearly 20 years, Martin Engineering's Foundations™ Books have taught industry personnel to operate and maintain clean and safe belt conveyors. The Foundations™ Book, fourth edition, focuses on improving belt conveyors by controlling fugitive material. "The Practical Resource for Total Dust and Material Control," is a 576-page hard cover volume that provides information of value to industries where the efficient handling of bulk materials is a key to productivity and profitability.

Expanding upon the book, our Foundations™ Training Program addresses the design and development of more productive belt conveyors, and is offered in three customizable seminars. Attendees gain a better understanding of conveyor safety and performance, helping to justify upgrade investments and increase profitability.



Martin Engineering USA

One Martin Place
Neponset, IL 61345-9766 USA
800 544 2947 or 309 852 2384
Fax 800 814 1553
www.martin-eng.com

**COMPANY WITH
QUALITY SYSTEM
CERTIFIED BY DNV
= ISO 9001:2008 =**