

# Martin® Inspection Door HD



Available in mild steel or stainless steel, the [Martin® Inspection Door HD](#) provides quick and easy access to belt cleaners and other components inside chutes and enclosures for inspection or service.

## BENEFITS

- Dust-Tight Seal**  
 Rubber seal is protected by a steel channel and prevents material escape.
- Built for Tough Conditions**  
 Steel door withstands typical positive and negative pressure applications.
- Simple Installation**  
 Door can be bolted or welded to enclosure wall. Bolt hole pattern matches Martin® Inspection Doors.
- Available with Wear Liner**  
 Door can be ordered with AR500 wear liner welded to the inside.
- “Low-Profile” Design**  
 Door height of 2.94 inches (75 mm) with handle in latched position.
- Lockable Latch**  
 All doors come standard with a lockable latch.
- Matches Your Application**  
 Six sizes available, from 9 X 12 to 24 X 24 inches (229 X 305 to 610 X 610 mm). Custom sizes are not available.

## MARTIN® INSPECTION DOOR HD

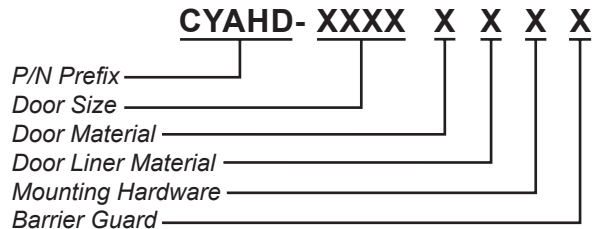

**DOOR SIZE**  
 Approximate door size in inches (width x height)

**DOOR MATERIAL**  
**C:** 304 Stainless Steel  
**S:** 316 Stainless Steel  
**Ø:** Painted Mild Steel

**DOOR LINER MATERIAL**  
**5:** AR500  
**Ø:** No Liner  
**Ø = BLANK**

**MOUNTING HARDWARE**  
**M:** With Mounting Hardware  
**Ø:** Without Mounting Hardware

**BARRIER GUARD**  
**G:** With Barrier Guard  
**Ø:** Without Barrier Guard

**LABELS**  
 Add “NL” at the end of the part number for no labels

# TECHNICAL DATA SHEET

## MARTIN® INSPECTION DOOR HD WITH HI-TEMP SEAL

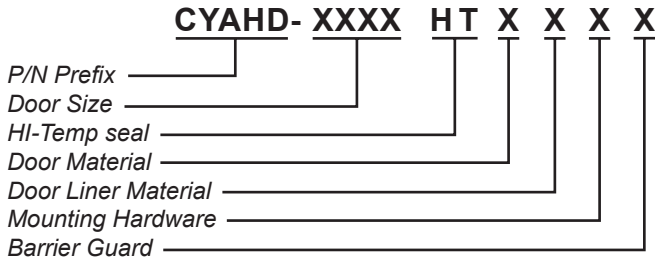

### DOOR SIZE

Approximate door size in inches (width x height)

### DOOR MATERIAL

**C:** 304 Stainless Steel  
**S:** 316 Stainless Steel  
**Ø:** Painted Mild Steel

### DOOR LINER MATERIAL

**5:** AR500  
**Ø:** No Liner

**Ø = BLANK**

### MOUNTING HARDWARE

**M:** With Mounting Hardware  
**Ø:** Without Mounting Hardware

### BARRIER GUARD

**G:** With Barrier Guard  
**Ø:** Without Barrier Guard

### LABELS

Add "NL" at the end of the part number for no labels

## HD ACCESS DOOR REPLACEMENT KIT

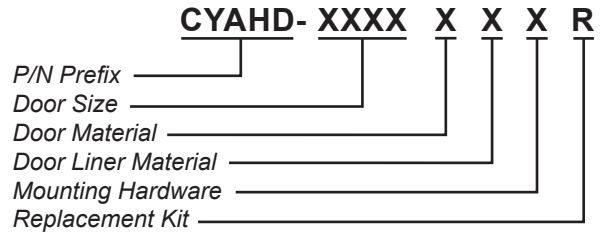

### DOOR SIZE

Approximate door size in inches (width x height)

### DOOR MATERIAL

**C:** 304 Stainless Steel  
**S:** 316 Stainless Steel  
**Ø:** Painted Mild Steel

### DOOR LINER MATERIAL

**5:** AR500  
**Ø:** No Liner

**Ø = BLANK**

### MOUNTING HARDWARE

**M:** With Mounting Hardware  
**Ø:** Without Mounting Hardware

Martin® Steel Inspection Door HD Part Numbers						
	CYAHD-0912	CYAHD-1214	CYAHD-1218	CYAHD-1818	CYAHD-1824	CYAHD-2424
"A"	11.25 (286)	14.19 (360)	14.19 (360)	20.25 (514)	20.25 (514)	25.94 (659)
"B"	14.38 (365)	16.25 (413)	20.25 (514)	20.25 (514)	26.19 (665)	25.94 (659)
"C"	8.75 (222)	11.69 (297)	11.69 (297)	17.75 (451)	17.75 (451)	23.44 (595)
"D"	11.88 (302)	13.75 (349)	17.75 (451)	17.75 (451)	23.69 (602)	23.44 (595)
"E"	2.81 (71)	2.81 (71)	2.81 (71)	2.81 (71)	4.81 (122)	4.81 (122)

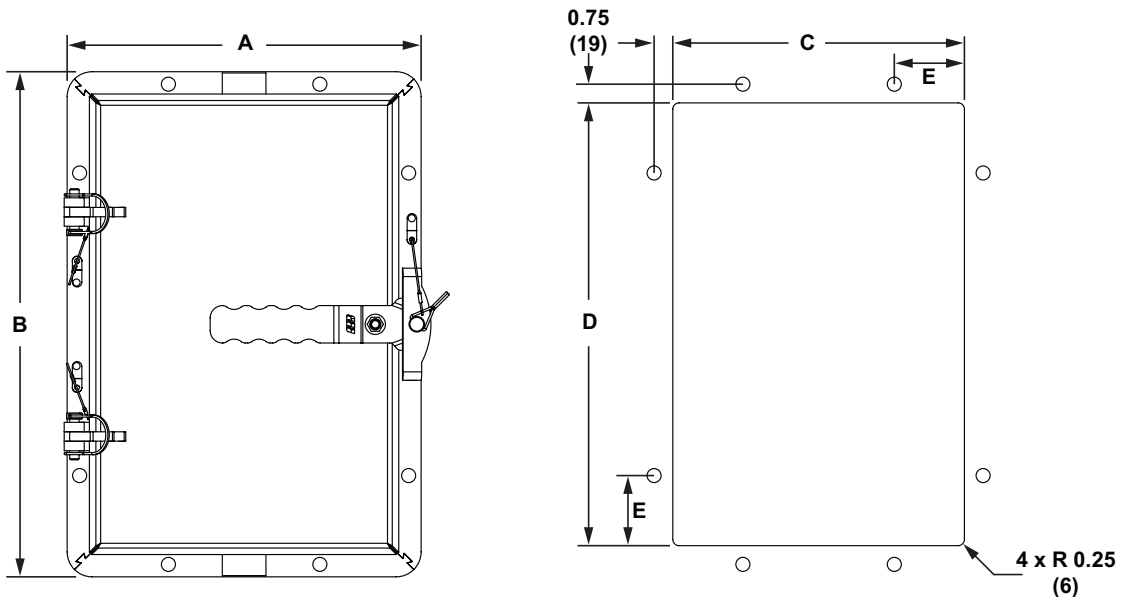

### Martin Engineering USA

One Martin Place  
Neponset, IL 61345-9766 USA  
800 544 2947 or 309 852 2384  
Fax 800 814 1553  
www.martin-eng.com

**COMPANY WITH  
QUALITY SYSTEM  
CERTIFIED BY DNV  
= ISO 9001:2008 =**

**Problem Solved™ GUARANTEED!**

Form No. L3983-01/25  
© Martin Engineering Company 2013, 2025